

Quartz Cerenkov and GEM Detector R&D at ISU: for PREX-II, CREX and MOLLER

Dustin McNulty
Idaho State University
dustinmcnulty@isu.edu

October 28, 2021

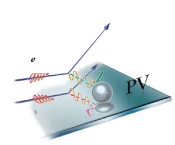



Quartz Cerenkov and GEM Detector R&D at ISU

Outline

- Motivation: PREX-II, CREX, and MOLLER
- Design Considerations: particle counting and tracking
 - Radiation hardness (for high flux integration)
 - Resolution, efficiency, and systematic error
- Thin Quartz Detectors
 - Main Integrating
 - Small Angle Monitors (SAMs)
- Gaseous Electron Multiplier (GEM) Tracking System
- Thick Quartz-tungsten Detector (Shower-max)
- Summary and Future Plans

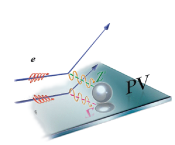

The Weak Force: Oh, I didn't know that?

- Through a series of nuclear reactions, four protons (hydrogen nuclei) in the core of our Sun combine to form a helium nucleus emitting two positrons and two neutrinos and releasing 27 MeV of energy:

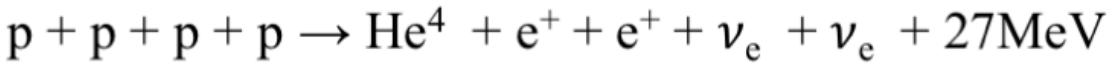

- Thermonuclear fusion--Perhaps the most important reaction for all life on planet Earth is caused by a fundamental force of nature that is rarely discussed in the classroom: Weak Interactions or the weak nuclear force

- Responsible for nearly all radioactive decay processes
- Beta decay is most common
- Theoretical understanding is at same level as Quantum Electro Dynamics

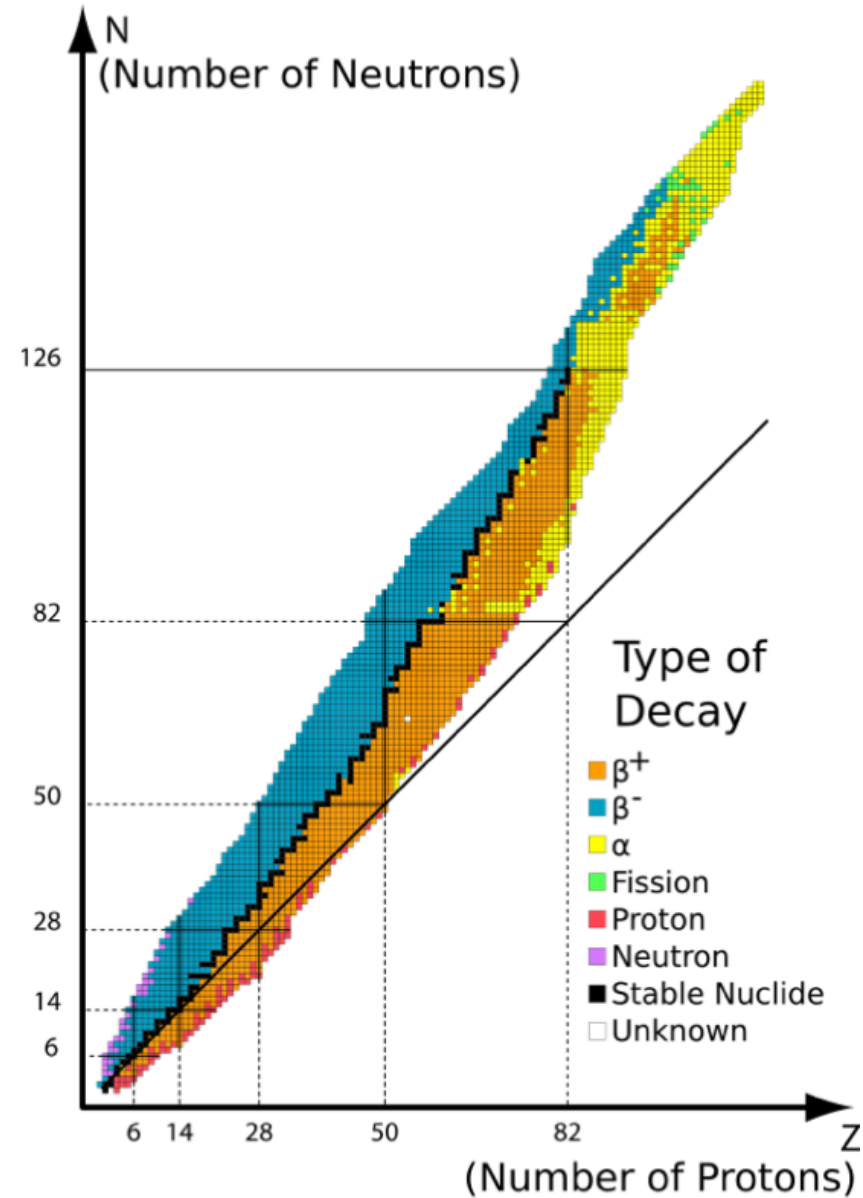

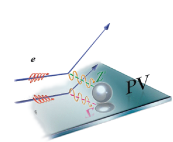

Beta Decay Examples

- β^- decay: $n \rightarrow p + \bar{\nu}_e + e^-$

-- Moves nuclei up the periodic table ($Z \rightarrow Z + 1$)

Beta-minus Decay

Carbon-14

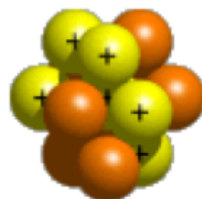

6 protons
8 neutrons



Nitrogen-14

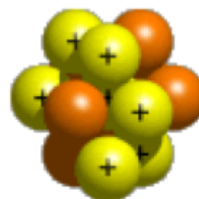

7 protons
7 neutrons



Antineutrino



Electron

- β^+ decay: $p \rightarrow n + \nu_e + e^+$

-- Moves nuclei down in the periodic table ($Z \rightarrow Z - 1$)

Beta-plus Decay

Carbon-10



6 protons
4 neutrons



Boron-10

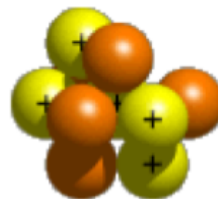

5 protons
5 neutrons



Neutrino



Positron

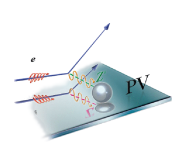

Beta Decay – Nature’s Window into the Weak-nuclear Force

A Quick History:

- 1899 Rutherford Rutherford classifies three types of radioactive emissions: alpha, beta, and gamma
- 1931 Pauli postulates existence of neutrino to explain non-discrete energy spectra of β -decay electrons
- 1933 Fermi develops theory to explain β decay -- precursor to theory for weak interaction
- 1956 Neutrino discovered by experiment. $\bar{\nu}_e + p \rightarrow n + e^+$
- 1957 Parity Violation discovered in β decay of ^{60}Co

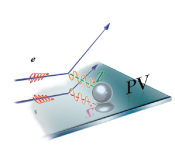

Fermi's Interaction – Precursor to Weak Theory

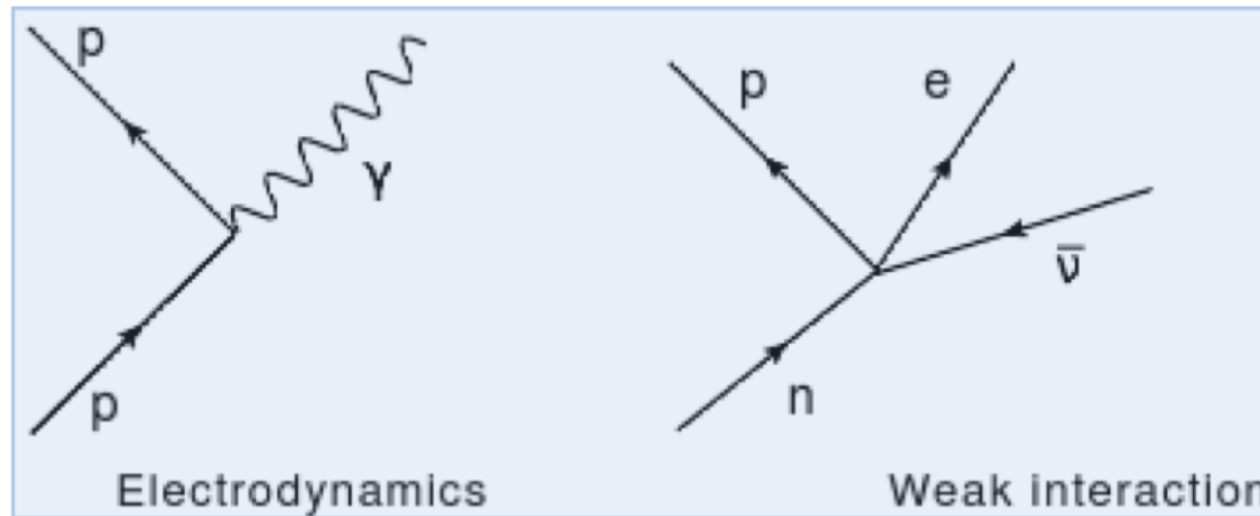

- Fermi's theory invented a physical mechanism for β decay
- 4-fermion contact interaction at single space-time point
- Modeled after electrodynamic field interactions -- where \vec{J}_E of a charged particle interacts with \vec{A} to create a photon
- For Fermi's theory, the ``weak'' current of pn-pair interacts with the ``weak'' current of $e\bar{\nu}$ -pair
- Fermi's ``weak'' currents/potentials had vector form just as EM.

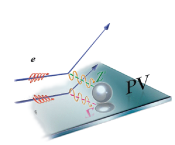

Parity Symmetry

$$\mathbf{P}: \begin{bmatrix} x \\ y \\ z \end{bmatrix} \longrightarrow \begin{bmatrix} -x \\ -y \\ -z \end{bmatrix}$$

- Parity operation: Spatial reflection through the origin
- “Even” functions: $\mathbf{P} f(x, y, z) \Rightarrow +f(x, y, z)$
- “Odd” functions: $\mathbf{P} f(x, y, z) \Rightarrow -f(x, y, z)$
- *Classically*, scalar quantities (m, E, ρ, V, M, \dots) are mainly “even” while vector quantities ($\vec{x}, \vec{a}, \vec{F}, \vec{E}, \vec{A}, \dots$) are mainly “odd”
- *Quantum Mechanically*, if \mathbf{P} commutes with the Hamiltonian, then Parity is conserved (invariant or symmetric)
- Fundamental symmetry of nature known to be conserved in electromagnetism, strong interactions, and gravity

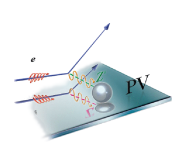

β^- Decay and Standard Model

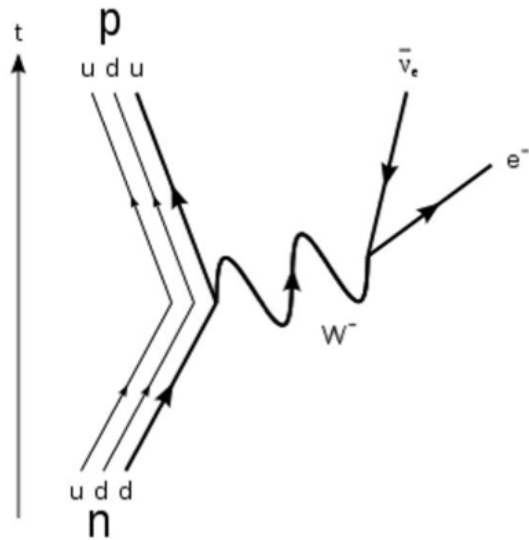

	mass → $\approx 2.3 \text{ MeV}/c^2$ charge → $2/3$ spin → $1/2$ u up	mass → $\approx 1.275 \text{ GeV}/c^2$ charge → $2/3$ spin → $1/2$ c charm	mass → $\approx 173.07 \text{ GeV}/c^2$ charge → $2/3$ spin → $1/2$ t top	mass → 0 charge → 0 spin → 1 g gluon	mass → $\approx 126 \text{ GeV}/c^2$ charge → 0 spin → 0 H Higgs boson
QUARKS	mass → $\approx 4.8 \text{ MeV}/c^2$ charge → $-1/3$ spin → $1/2$ d down	mass → $\approx 95 \text{ MeV}/c^2$ charge → $-1/3$ spin → $1/2$ s strange	mass → $\approx 4.18 \text{ GeV}/c^2$ charge → $-1/3$ spin → $1/2$ b bottom	mass → 0 charge → 0 spin → 1 γ photon	
	mass → $0.511 \text{ MeV}/c^2$ charge → -1 spin → $1/2$ e electron	mass → $105.7 \text{ MeV}/c^2$ charge → -1 spin → $1/2$ μ muon	mass → $1.777 \text{ GeV}/c^2$ charge → -1 spin → $1/2$ τ tau	mass → $91.2 \text{ GeV}/c^2$ charge → 0 spin → 1 Z Z boson	GAUGE BOSONS
LEPTONS	mass → $< 2.2 \text{ eV}/c^2$ charge → 0 spin → $1/2$ ν_e electron neutrino	mass → $< 0.17 \text{ MeV}/c^2$ charge → 0 spin → $1/2$ ν_μ muon neutrino	mass → $< 15.5 \text{ MeV}/c^2$ charge → 0 spin → $1/2$ ν_τ tau neutrino	mass → $80.4 \text{ GeV}/c^2$ charge → ± 1 spin → 1 W W boson	

- Julian Schwinger modifies Fermi's theory to incorporate parity violating potential term (V-A) and idea of intermediate vector bosons; Glashow, Weinberg, and Salam 1979 Nobel Prize
- W^\pm only couples to left-handed particles and right-handed anti-particles
- Z^0 couples predominantly to left-handed particles

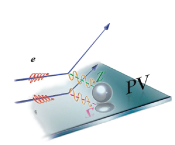

Why Parity-Violating Electron Scattering?

Provides model-independent determinations of nuclear and fundamental-particle weak-charge form factors and couplings with widespread implications for:

- Understanding nuclear and nucleon structure
 - Strange quark content of nucleon
 - Neutron radii of heavy nuclei \rightarrow density dependence of Symmetry Energy and EOS of nuclear matter; neutron stars; calibrate hadronic probe reactions on radioactive beams
- Search for physics Beyond the Standard Model (BSM)
 - Indirect searches using low energy ($Q^2 \ll M_Z^2$) precision electroweak tests at high intensity or precision frontier
 - complements direct searches at high energy frontier

JLab PVES Programs: HAPPEX, G0, PVDIS, PREX, Qweak, CREX
MOLLER, SoLID

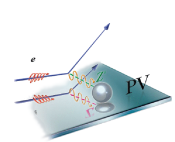

Parity-Violating Electron Scattering

Parity Transformation: Changing beam helicity equivalent to changing parity

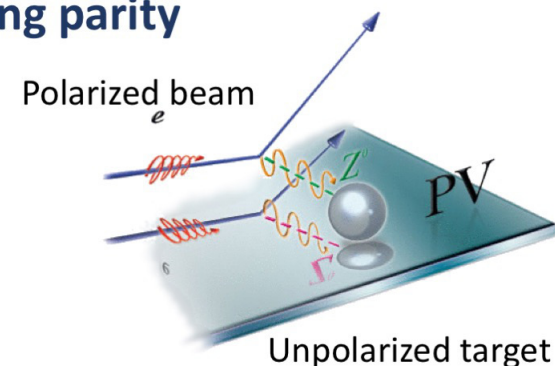
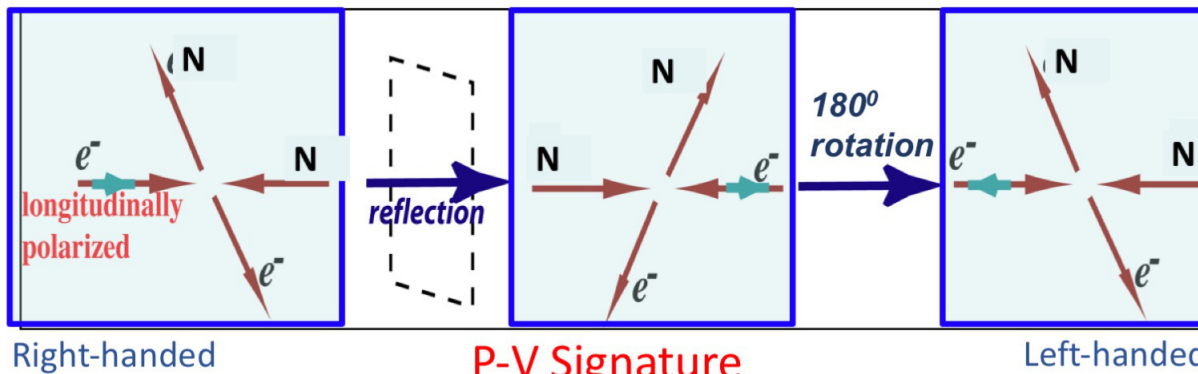

$$\sigma \approx \left| \begin{array}{c} \text{diagram with } \gamma \\ e^- \text{ and } N \end{array} + \begin{array}{c} \text{diagram with } z^0 \\ e^- \text{ and } N \end{array} \right|^2$$

- Access NC Weak amplitude via **EW interference**-dominated asymmetry measurement

$$= \left| \begin{array}{c} \text{diagram with } \gamma \\ e^- \text{ and } N \end{array} \right|^2 + h_e \left| \begin{array}{c} \text{diagram with } \gamma \\ e^- \text{ and } N \end{array} \right| \left| \begin{array}{c} \text{diagram with } z^0 \\ e^- \text{ and } N \end{array} \right| + \left| \begin{array}{c} \text{diagram with } z^0 \\ e^- \text{ and } N \end{array} \right|^2$$

- Flip sign of longitudinal polarization
- Measure fractional rate difference or **asymmetry**

$$A_{PV} = \frac{\sigma_R - \sigma_L}{\sigma_R + \sigma_L} \approx \frac{M_{Weak}^{NC}}{M_{EM}} \approx \frac{G_F Q^2}{4\pi\alpha} \sim 10^{-4} \cdot Q^2 \text{ [}/GeV^2]$$

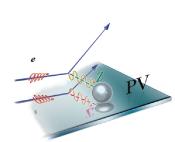

Blueprint of a PVES Experiment (E122 at SLAC)

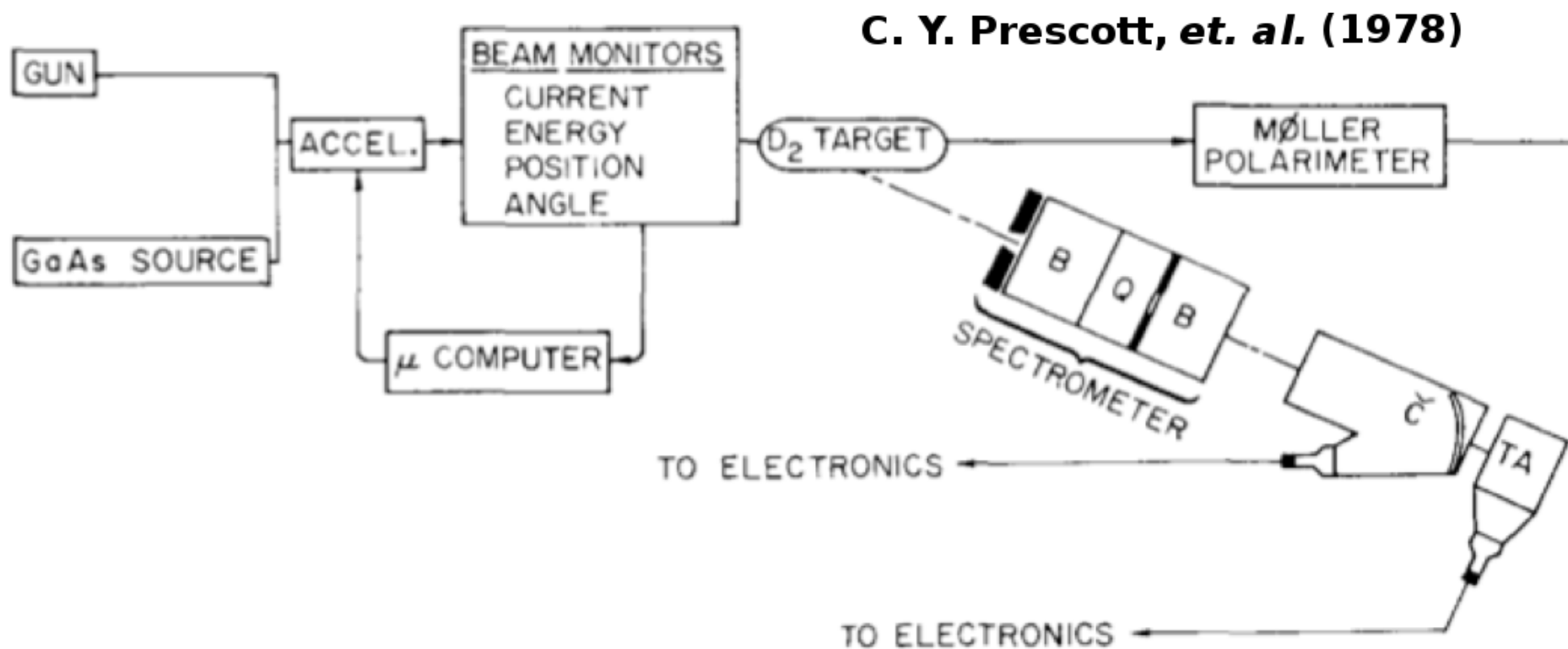

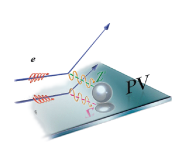

Anatomy of a PVES Experiment (E122 at SLAC)

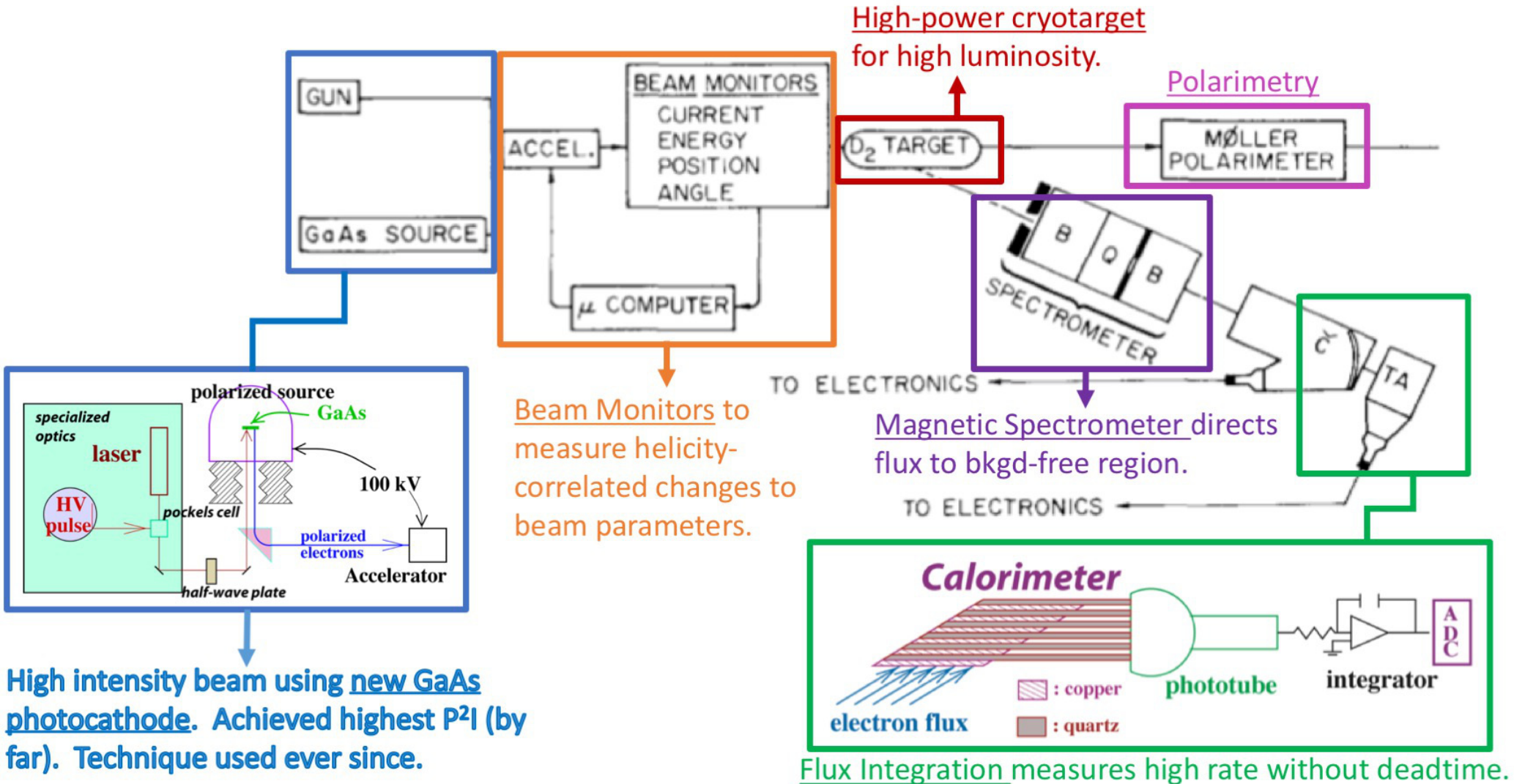

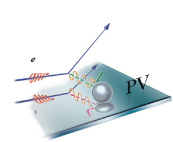

How to do a Parity Experiment

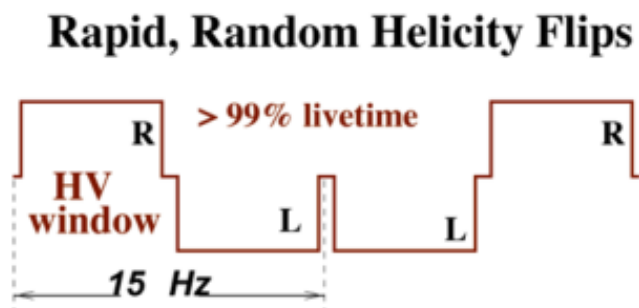
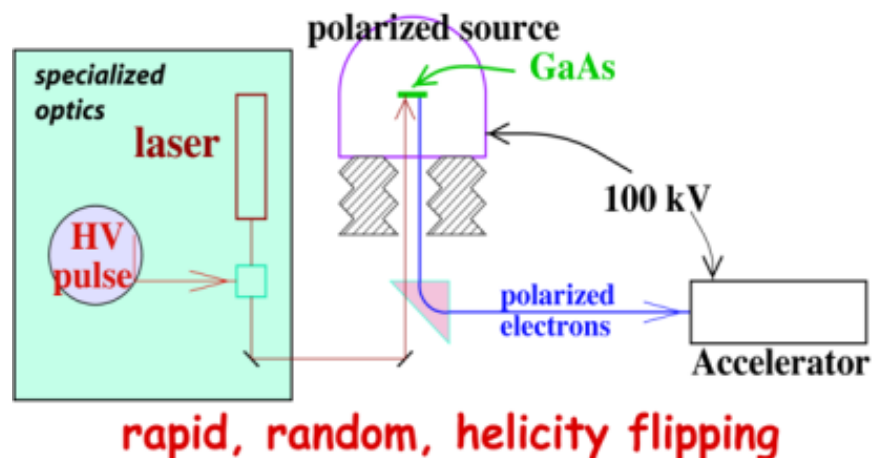

Measure flux F for each window

$$A_{\text{window pair}} = \frac{F_R - F_L}{F_R + F_L}$$

Flux Integration Technique:

HAPPEX: 2 MHz ($A_{PV} \sim 15\text{ppm}$)

HAPPEX-II: 100 MHz ($A_{PV} \sim 1.5\text{ppm}$)

PREX: 1 GHz ($A_{PV} \sim 0.5\text{ppm}$)

PREX-II: 2 GHz ($A_{PV} \sim 0.5\text{ppm}$)

MOLLER: 150 GHz ($A_{PV} \sim 0.035\text{ppm}$)

Signal Average N Windows Pairs: $A \pm \frac{\sigma(A)}{\sqrt{N_{\text{windows}}}}$

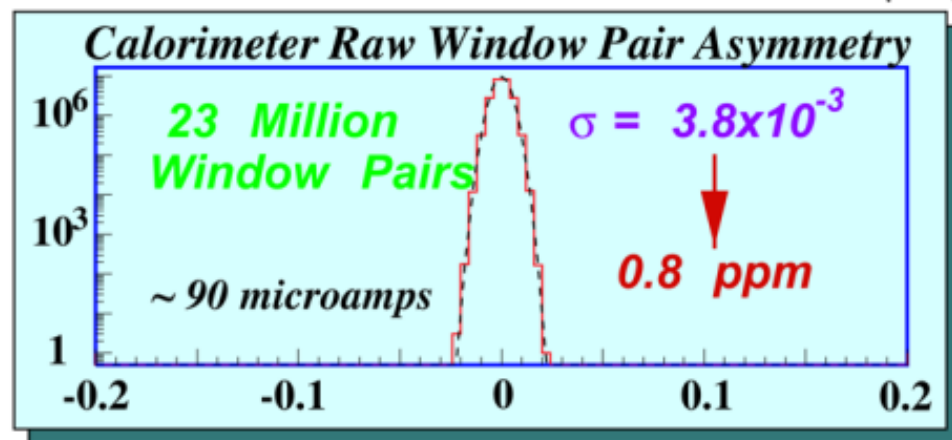
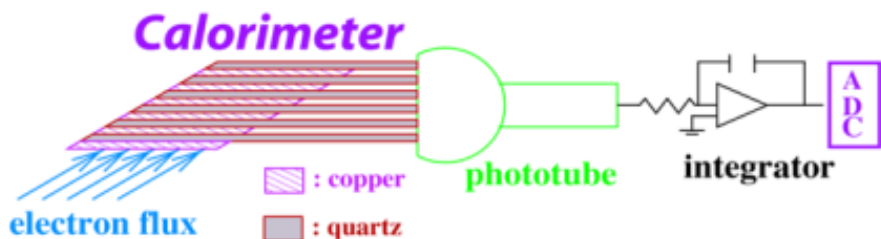

No non-gaussian tails to $\pm 5\sigma$

Detector signal noise dominated by electron counting statistics

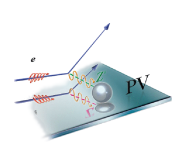

3 Decades of Technical Progress

photocathodes, polarimetry, high power cryotargets, nanometer beam stability, precision beam diagnostics, low noise electronics, *rad-hard dets*

- 1st generation
- 2nd generation
- 3rd generation
- 4th generation

E122 – 1st PVES Expt (late 70’s at SLAC)
 Mainz & MIT-Bates in mid 80’s
 JLab program launched in mid 90’s
 E158 at SLAC meas PV Møller scattering
 MOLLER at JLab in mid 2020’s

PVES Experiment Summary

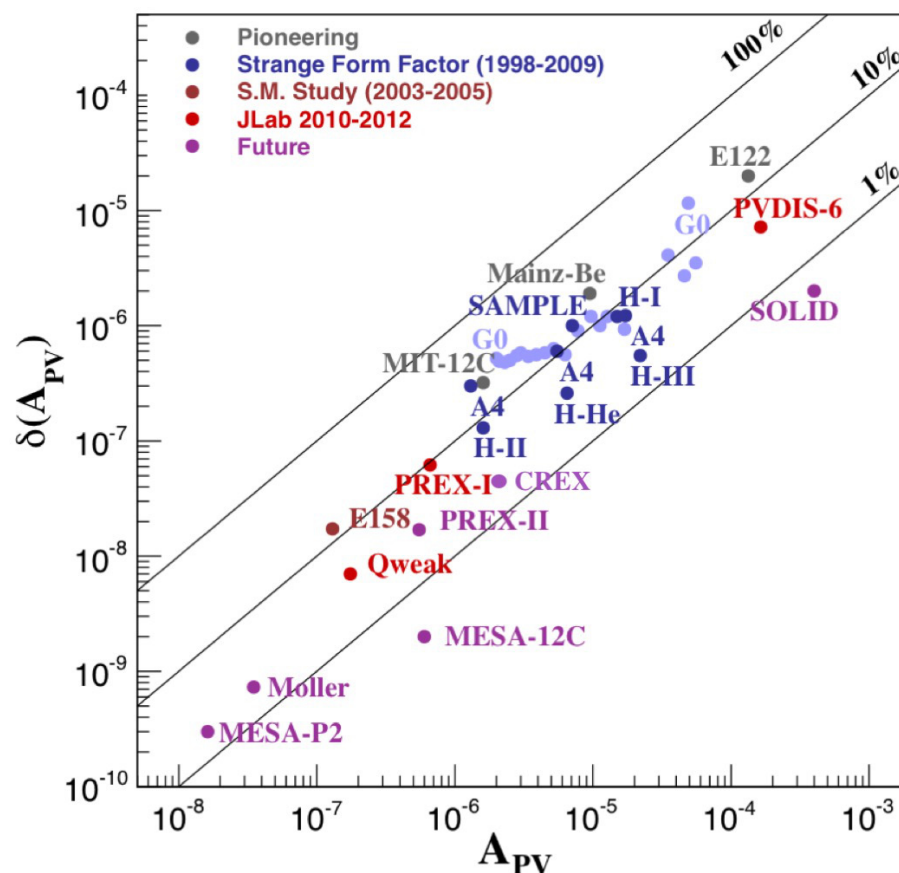

- Parity-violating electron scattering has become a precision tool!

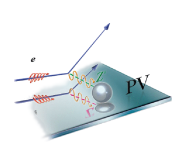

PREX/CREX Overview

PREX/PREX-II:

0.95 GeV e⁻ beam, 50-70 μA

0.5 mm thick ²⁰⁸Pb target

5° scattered electrons

$Q^2 = 0.0088 \text{ GeV}^2$, $A_{PV} \sim 0.5 \text{ ppm}$

680 hours, ~35M pairs

$\delta A_{PV} \sim 15 \text{ ppb (3\%)}$

- high polarization, ~89%
- helicity reversal at 240 & 30 Hz

- **New thin quartz detectors**

CREX:

2.22 GeV e⁻ beam, 150 μA

5 mm thick ⁴⁸Ca target

5° scattered electrons

$Q^2 = 0.037 \text{ GeV}^2$, $A_{PV} \sim 2 \text{ ppm}$

780 hours, ~40M pairs

$\delta A_{PV} \sim 80 \text{ ppb (4\%)}$

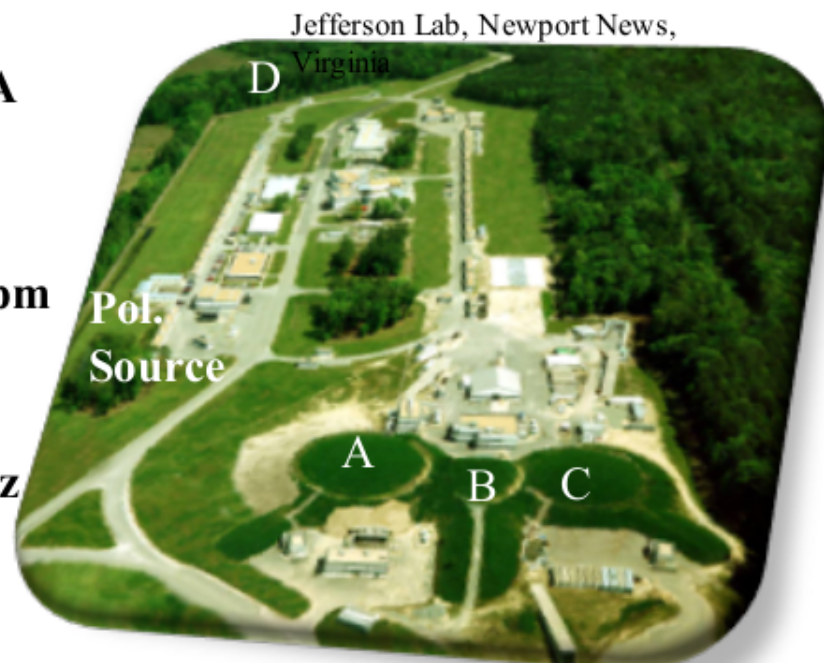

Symmetric High Resolution Spectrometers

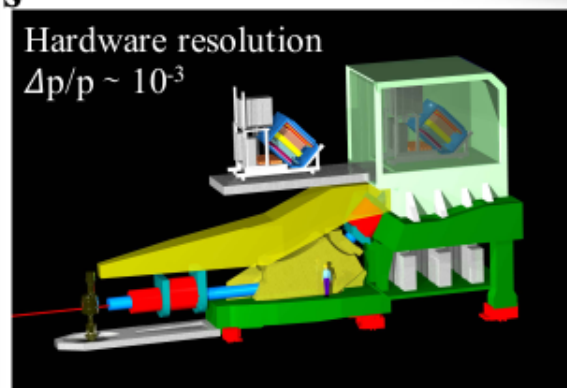

HRS and optics schematic

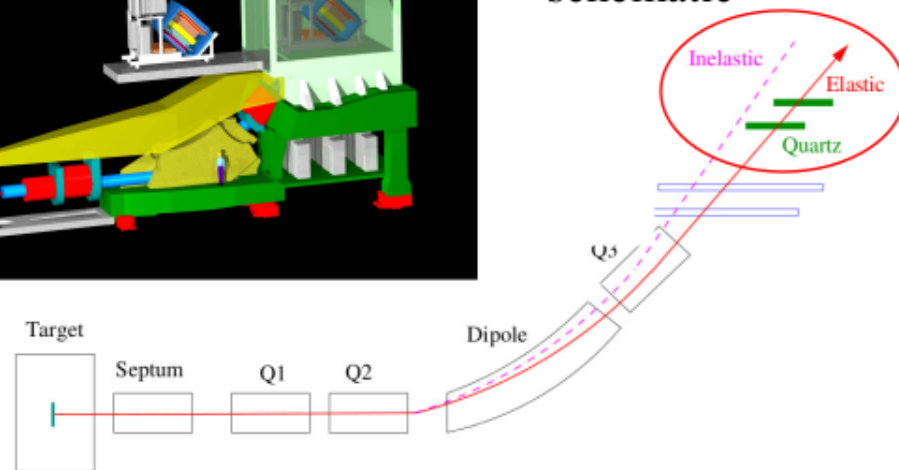

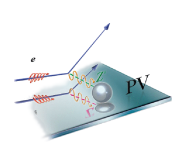

Requirements for PVES Integrating Detectors

- Radiation hardness – active medium must give consistent response under extreme and prolonged flux exposures
- Should count individual electrons with good ($\sim 20\%$) resolution – to minimize statistical error inflation
- Photo-sensitive device must give highly linear response (at 0.3% level for PREX-II/CREX) – so care must be taken to understand photo-cathode light levels and anode currents during integration mode A_{PV} measurements

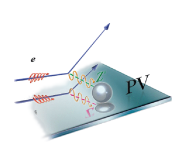

Integrating Detector Design change between PREX-I and PREX-II/CREX

- Orientation between quartz, pmt, and scattered electron changed
 - Allows capture of both sides of Cherenkov cone – instead of losing one side due to critical angle
 - Use TIR inside quartz as light guide – instead of aluminum air-core reflector to direct light to PMT
 - Less sensitivity to extra noise due to delta-ray production
- This change effectively doubles light yield and improves RMS by $\sqrt{2}$
- However, there is more light yield variation for electrons with different incident angles
- ❖ Design validated with G4 optical Monte Carlo benchmarked to “real” Testbeam data

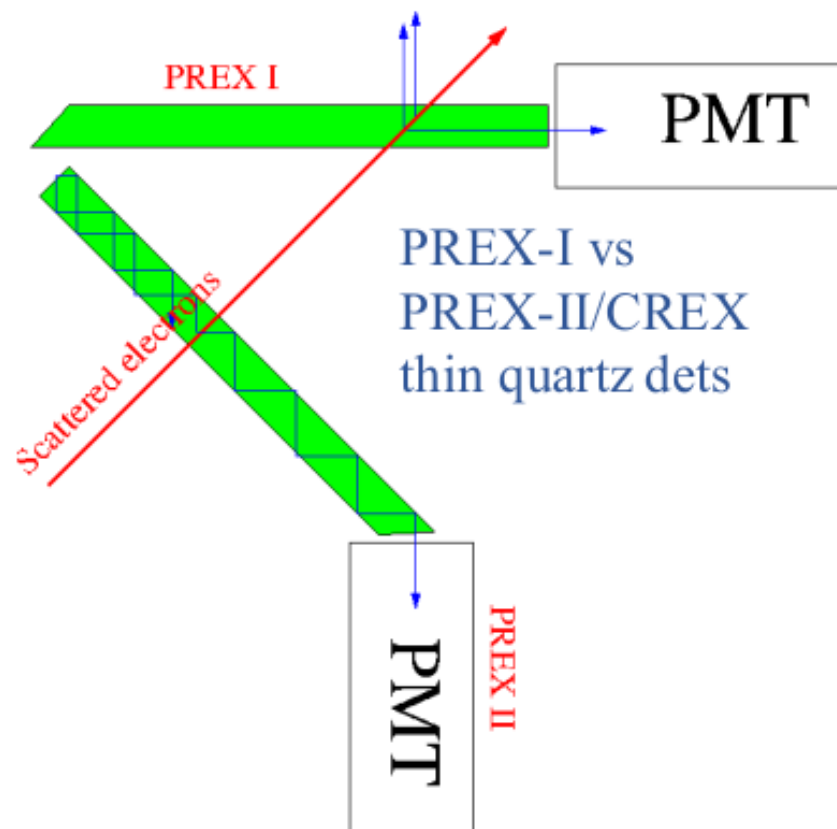

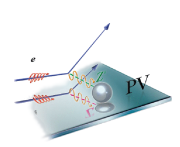

G4 Event Visualizations: PREX-I vs PREX-II/CREX

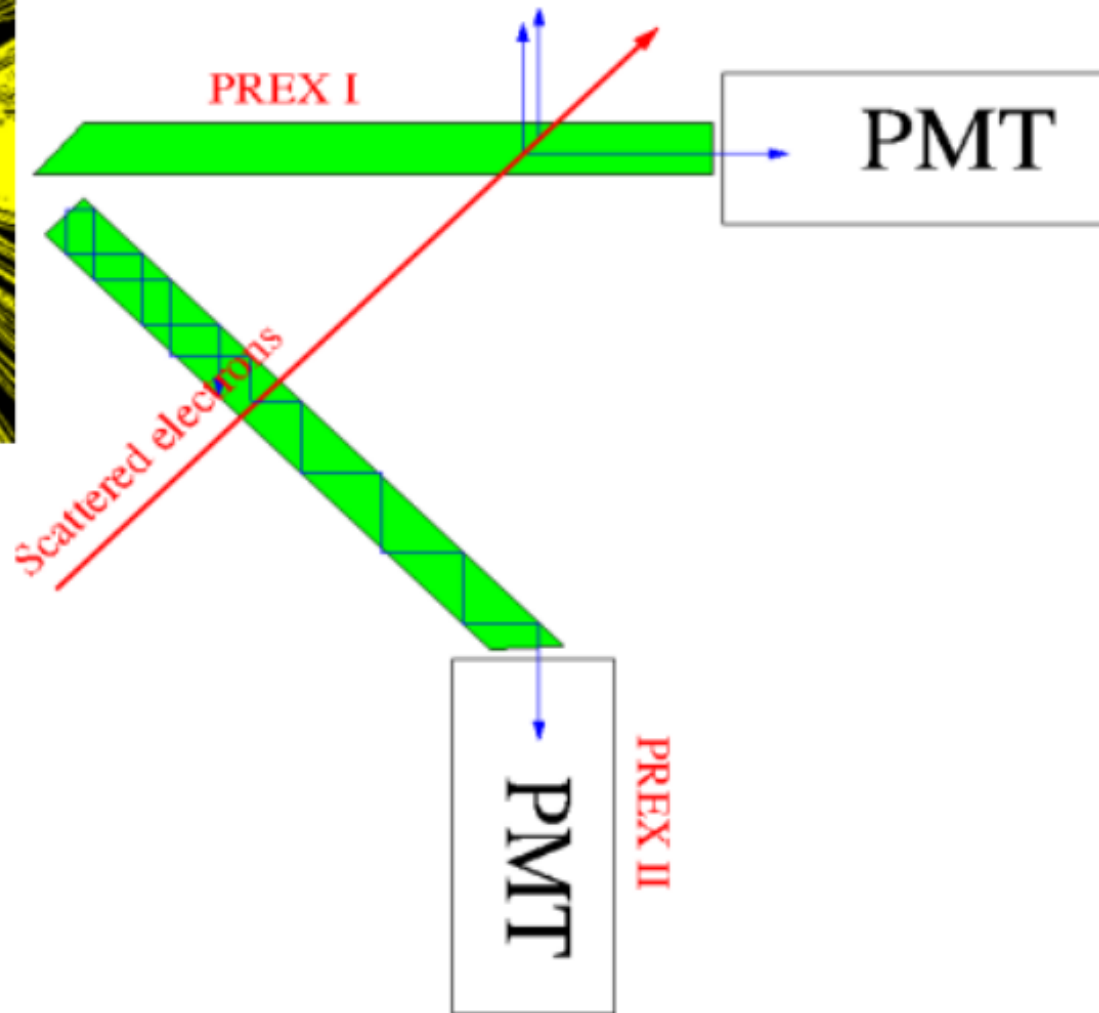
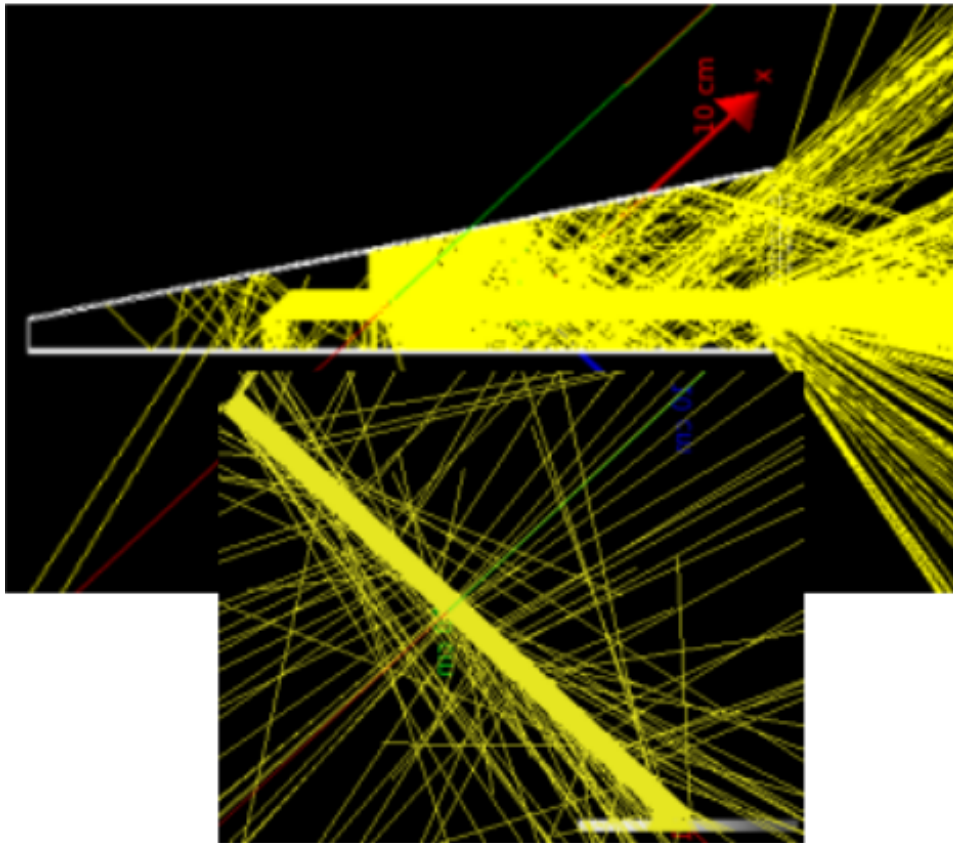

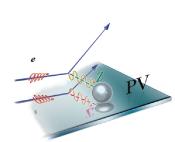

Main Integrating Detectors for PREX-II/CREX

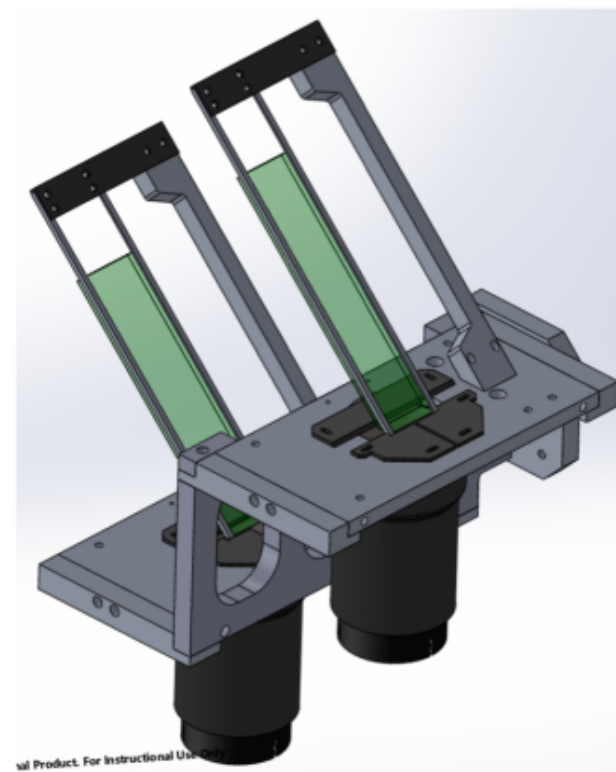
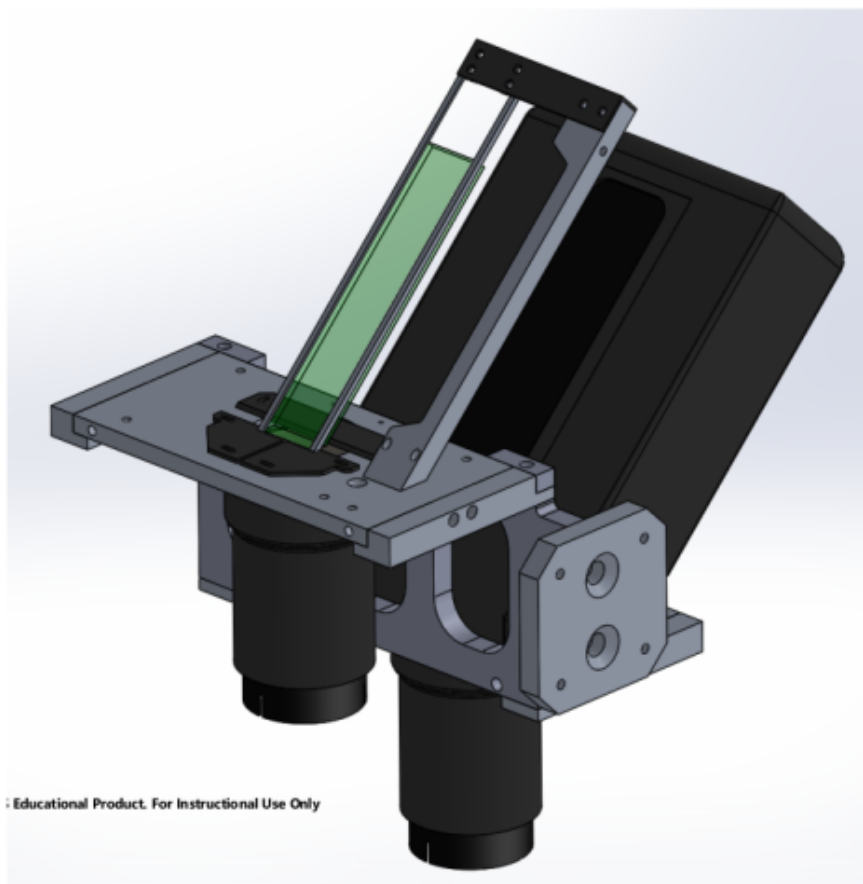
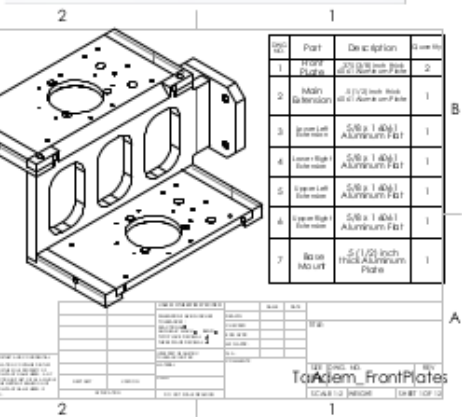
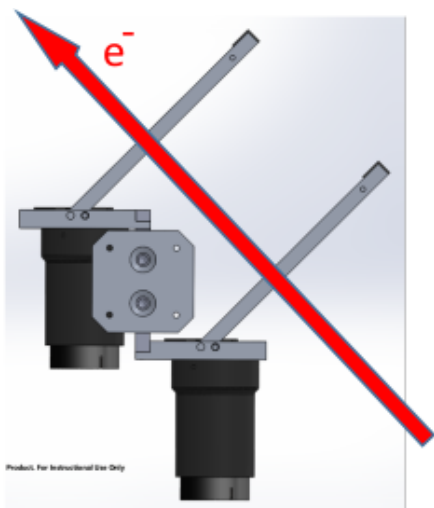

- Left and Right main detectors are mirror images of each other
- Both experiments, PREX-2 and CREX, used 5 mm thick quartz for all 4 detectors in each spectrometer (HRS)

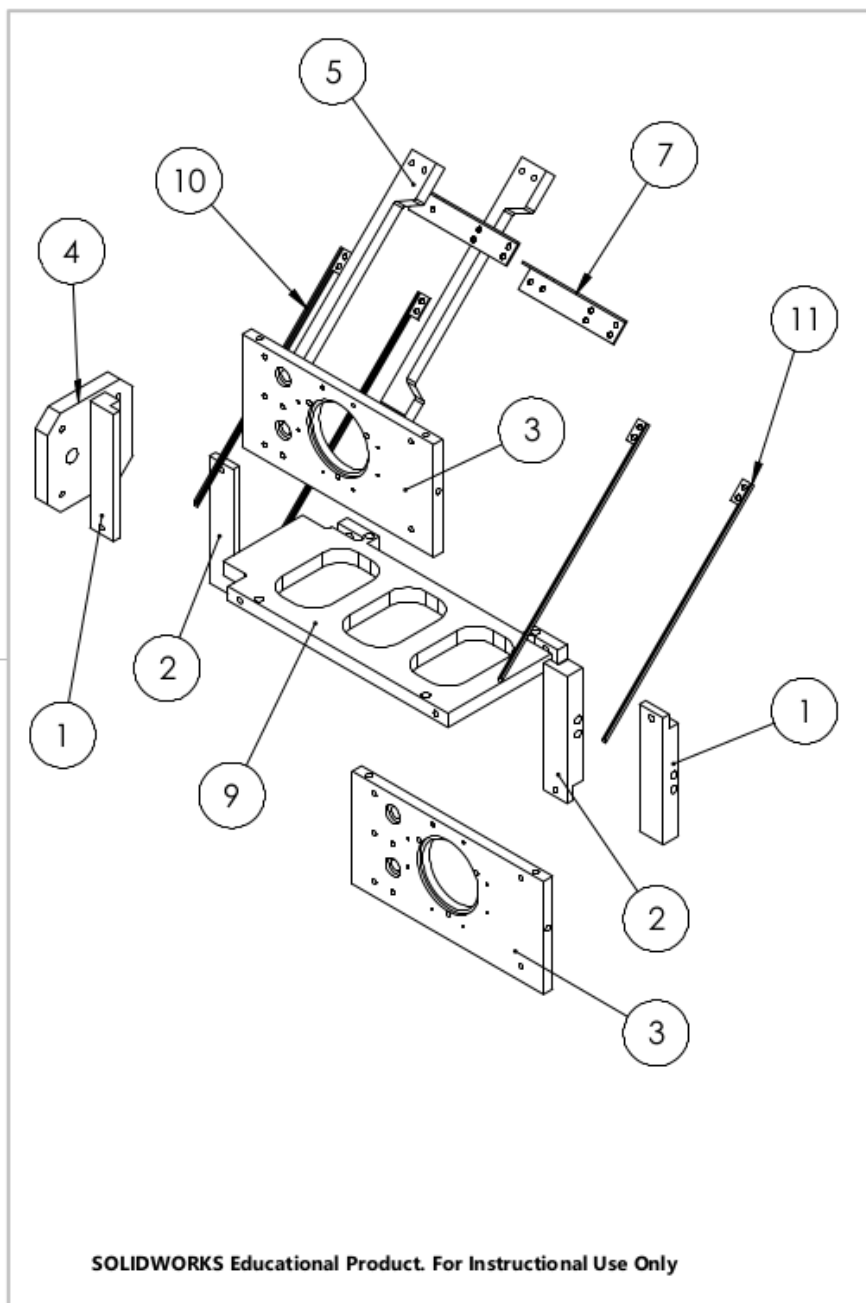
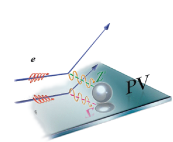

DWG NO.	Part	Description	Quantity
1	LL_TR Extension	5/8 x 1 6061 Aluminum Flat	4
2	LR_TL Extension	5/8 x 1 6061 Aluminum Flat	4
3	Front Plate RHR	.375 (3/8) inch thick 6061 Aluminum Plate	2
4	Base Mount	.5 (1/2) inch thick Aluminum Plate	1
5	L_Plate(1) RHR	1/2 X 1 6061 Aluminum Flat	2
6	L_Plate(1) LHR	1/2 X 1 6061 Aluminum Flat	2
7	L_Plate(2) RHR	1 X 1 X 1/16 Aluminum Angle 6063-T52 Aluminum Arch. Angle (Sharp Corner)	2
8	L_Plate(2) LHR	1 X 1 X 1/16 Aluminum Angle 6063-T52 Aluminum Arch. Angle (Sharp Corner)	2
9	Main Extension	.5 (1/2) inch thick 6061 Aluminum Plate	1
10	Rail Right	1/2 X 1/2 X 1/16 Aluminum Angle 6063-T52 Aluminum Arch. Angle (Sharp Corner)	4
11	Rail Left	1/2 X 1/2 X 1/16 Aluminum Angle 6063-T52 Aluminum Arch. Angle (Sharp Corner)	4

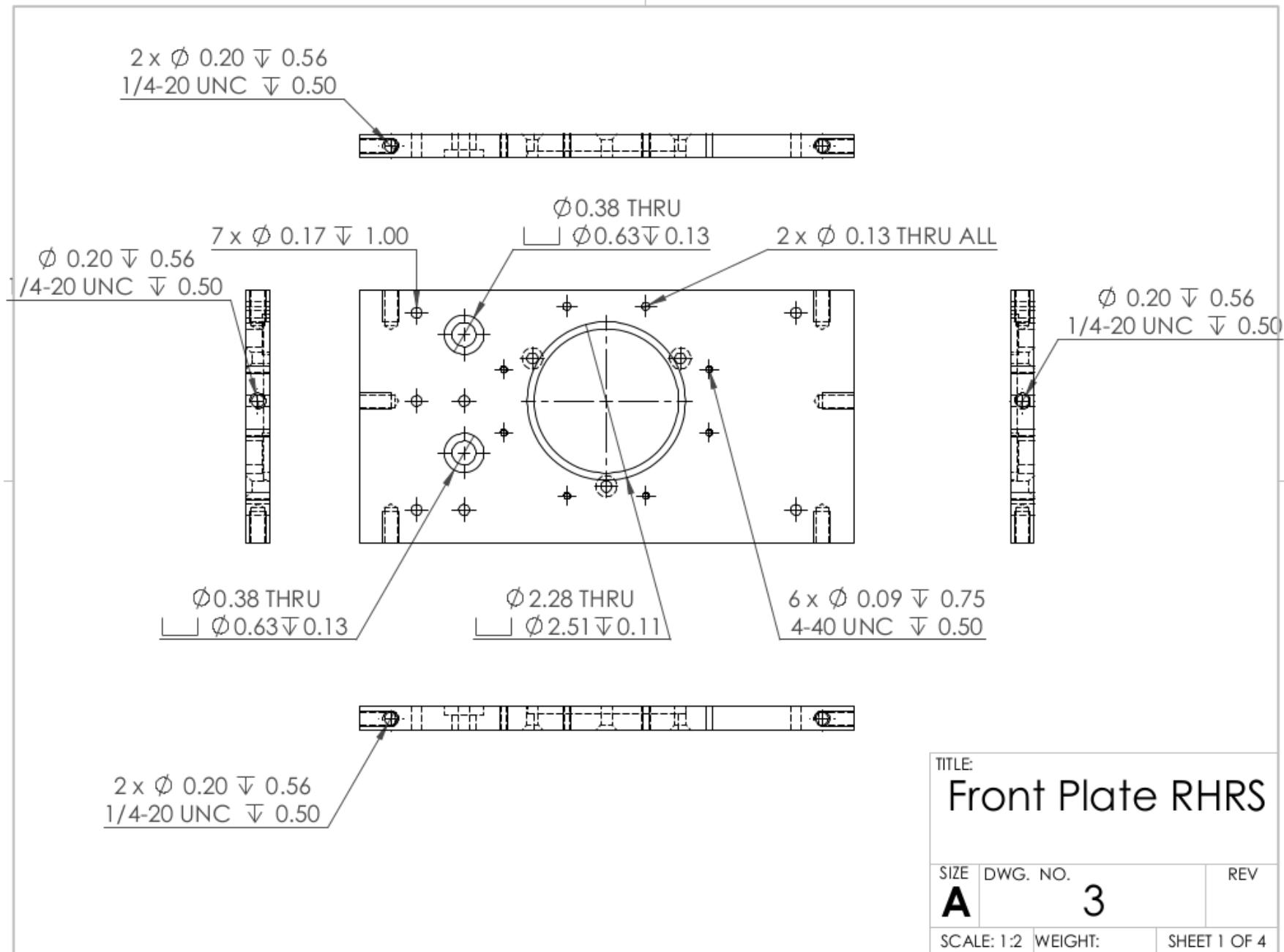
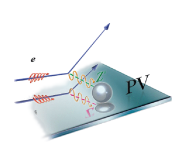

TITLE: Front Plate RHRS		
SIZE A	DWG. NO. 3	REV
SCALE: 1:2	WEIGHT:	SHEET 1 OF 4

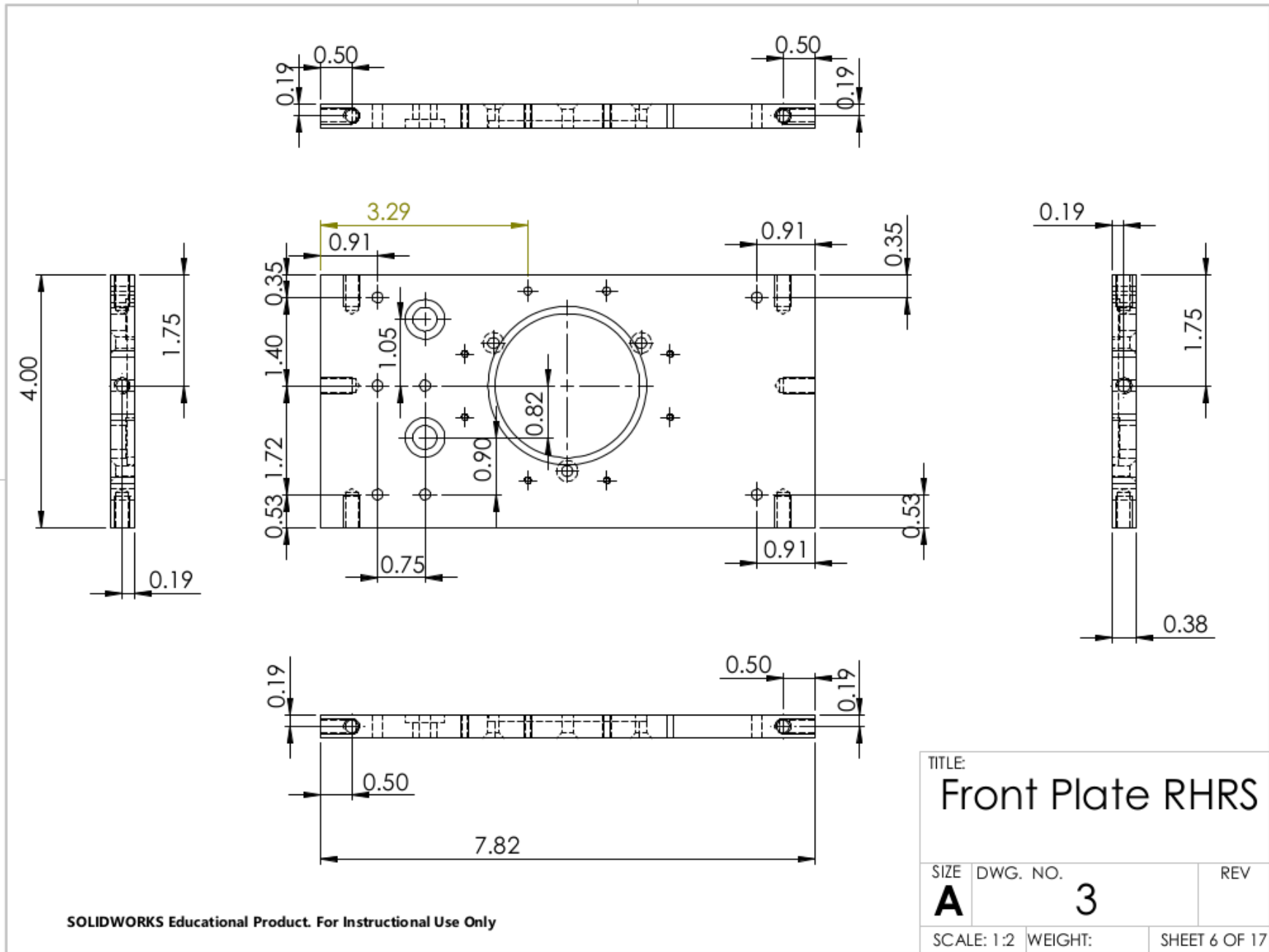
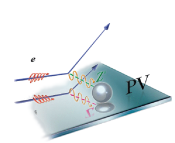

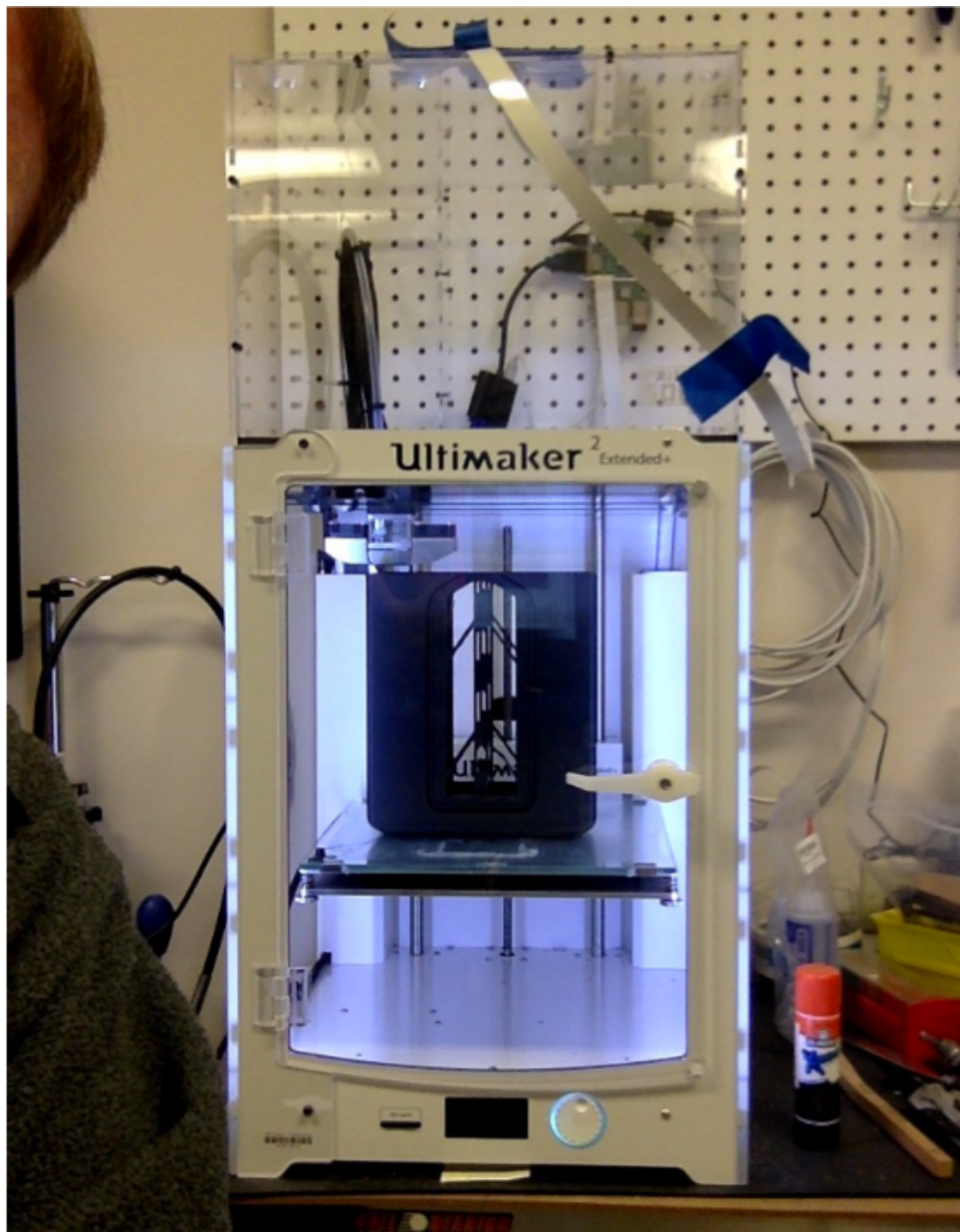
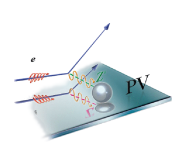

3D Printer making PREX
detector cover

Live Youtube feed:

<https://www.youtube.com/watch?v=AK89jruNle8>

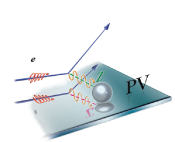

MAMI testbeam May 24-27, 2016

- $\frac{3}{4}$ shift total for PREX-II/CREX and SAM

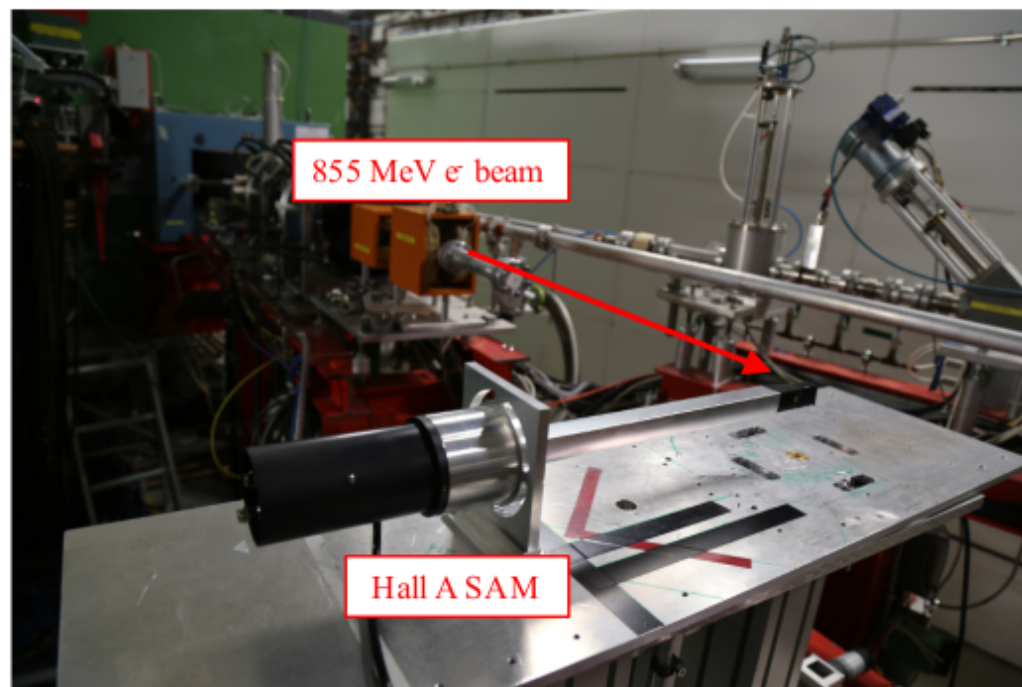
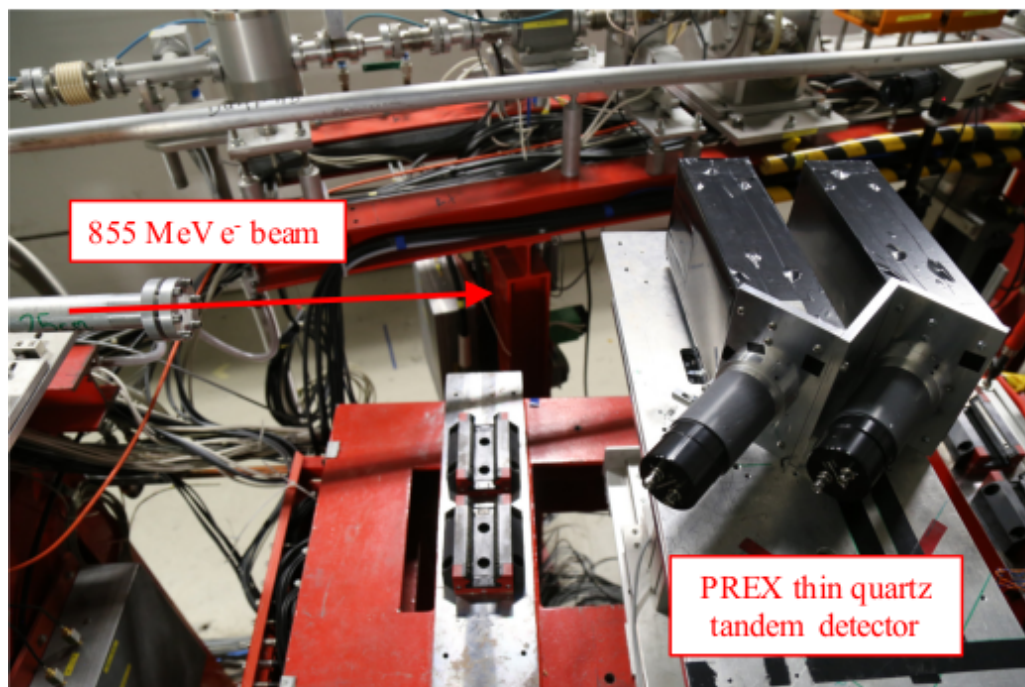

- 6mm and 10mm Tandem mount
- Near normal e^- incidence

- v3 (2015) SAM detector PE yield studies:
 - Miro27 and UVS light-guides
 - With and without 1cm tungsten pre-radiator

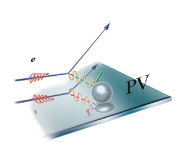

PREX-II/CREX Tandem Detector Tests

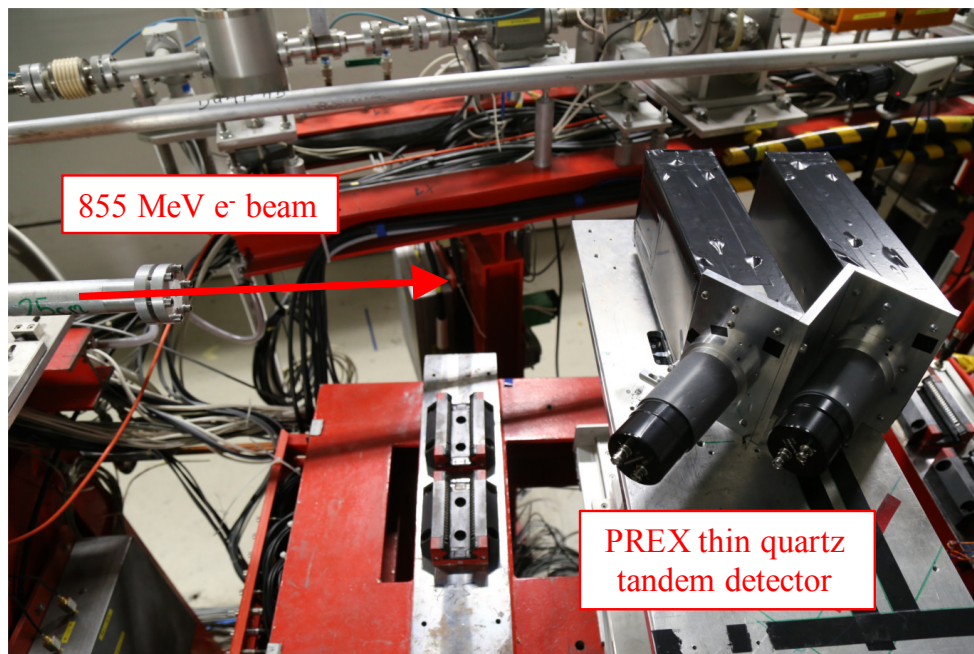

Spectrosil2000 thicknesses: 10mm and 6mm upstream and 6mm and 10mm downstream

e- beam
Centered on quartz at ~90°

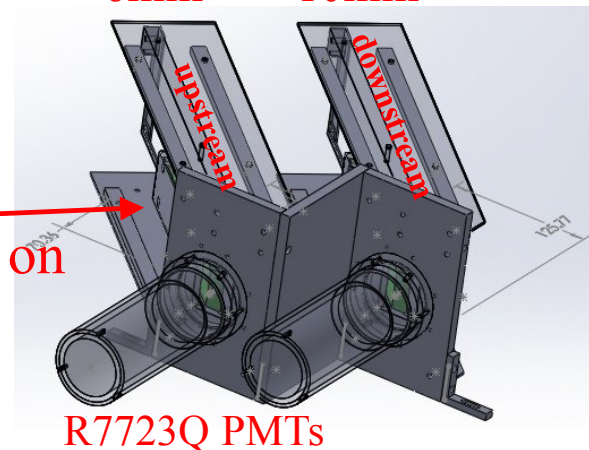

- Quartz spacing same as for rotary tandem mount (~16 cm)
- Used two Hamamatsu R7723Q pmts
- Quartz is wrapped with 1 mil Al. Mylar
- Took runs for each quartz thickness upstream and downstream
- Example raw data, pedestal fit, and ped-corrected ADC and PE dists

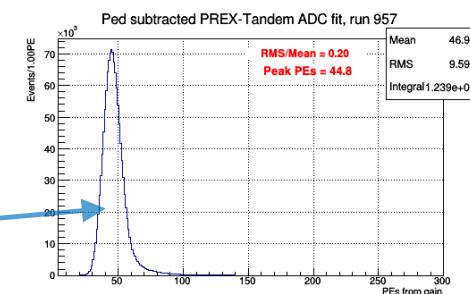
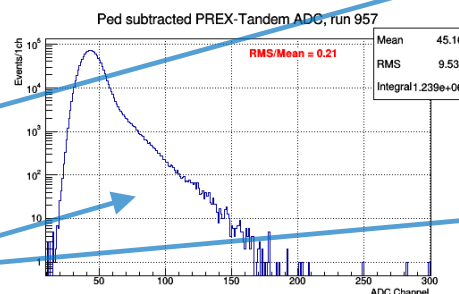
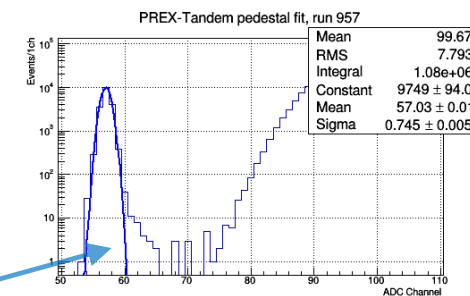
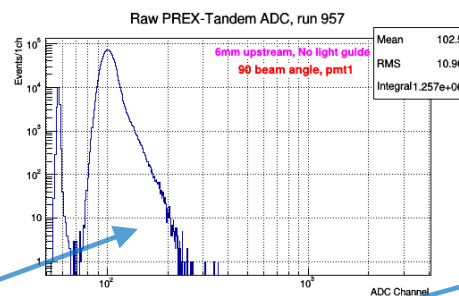

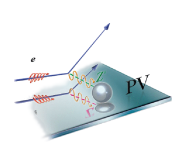

Optical Monte Carlo (qsim) Benchmarking

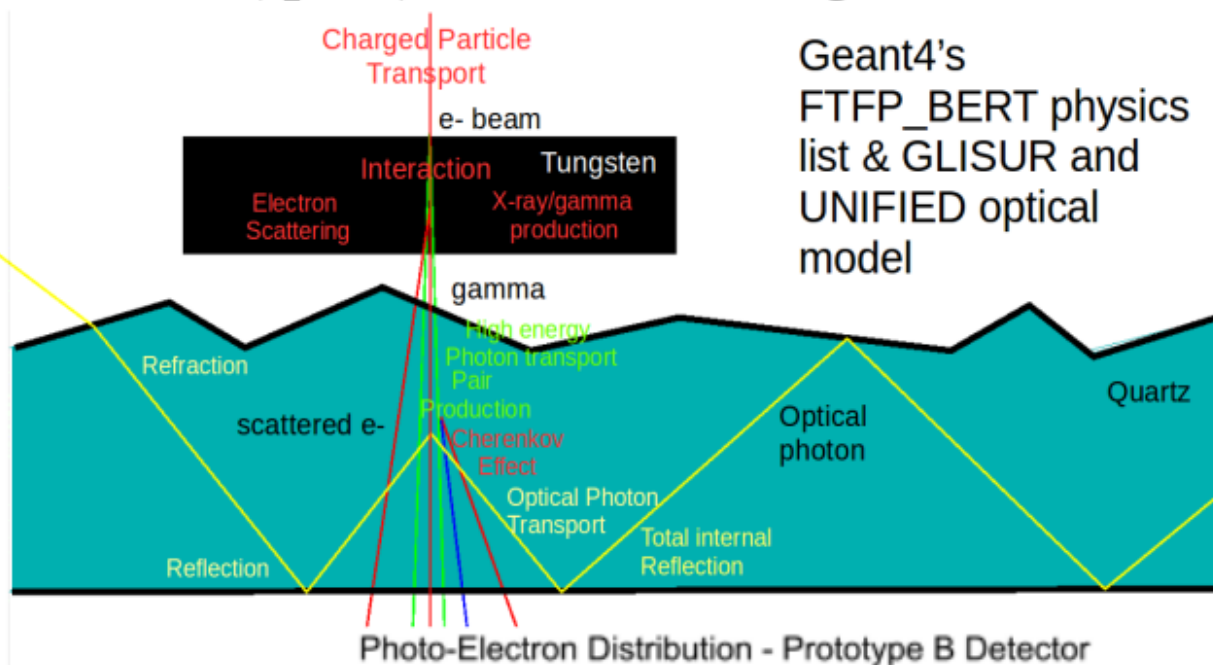
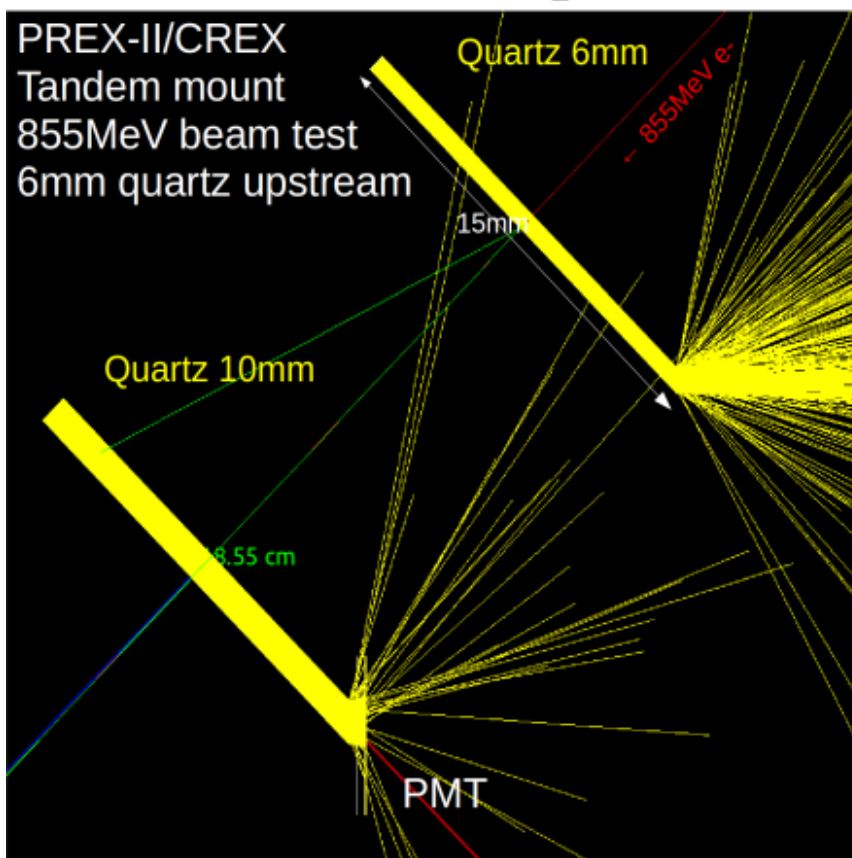

Geant4's FTFP_BERT physics list & GLISUR and UNIFIED optical model

Photo-Electron Distribution - Prototype B Detector

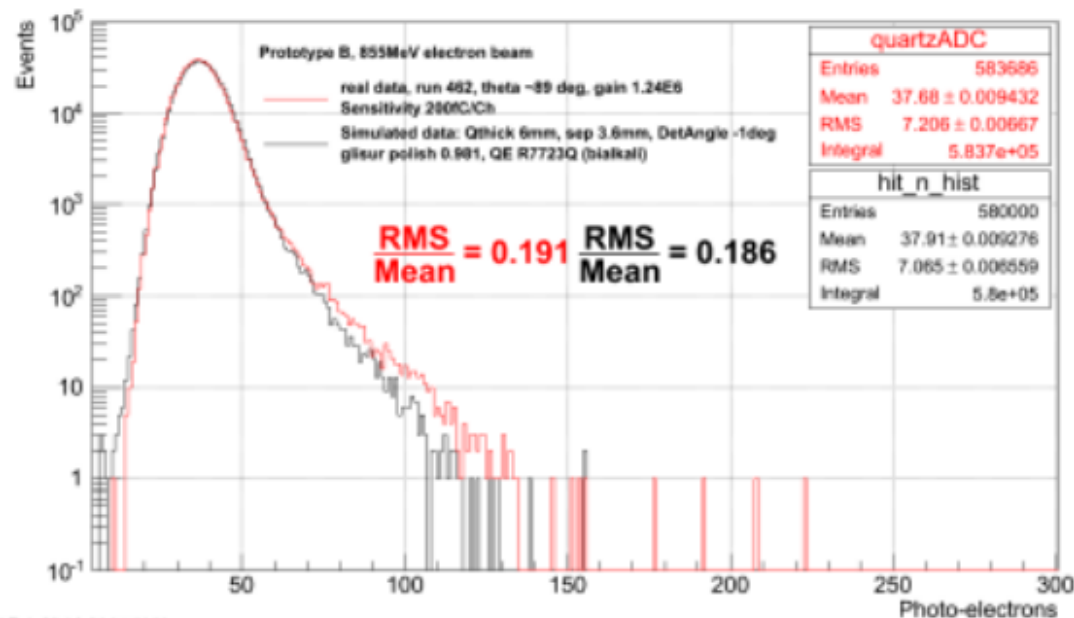

Fri Feb 26 14:44:35 2016

- Detailed geometry; pmt quantum efficiency sampling; refractive index dispersion; light attenuation in quartz; photo-cathode attenuation and reflection; quartz ground polish parameter
- Glisure ground polish parameter is tuned to make agreement between simulation and data

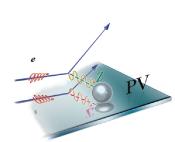

Optical Monte Carlo (qsim) Benchmarking

Peak PEs Vs Detector-Beam Angle

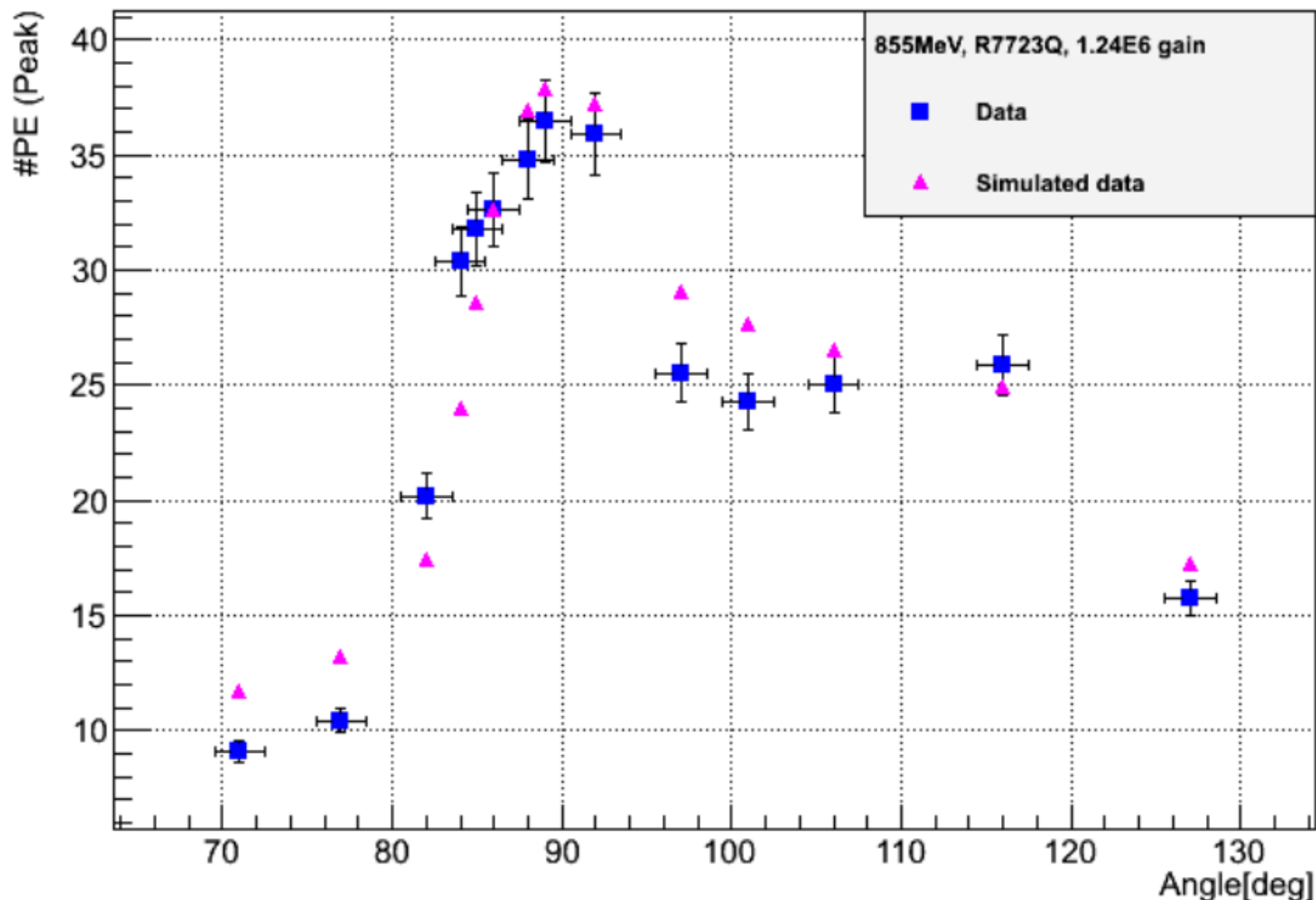

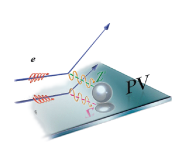

RHRS Tandem PREX-II/CREX Dets with GEMs

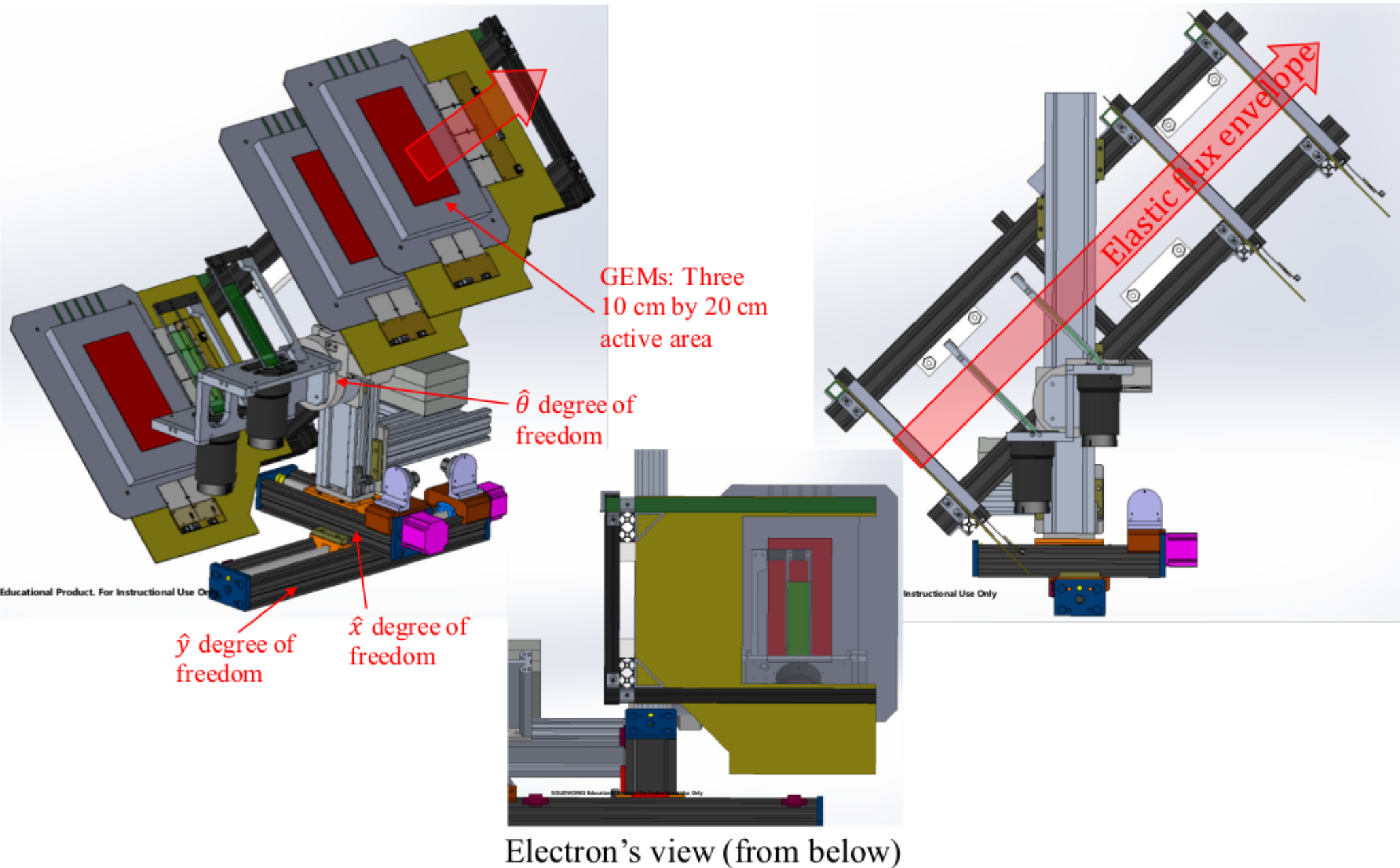

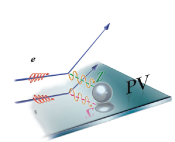

HRS Detector Package Torque Analysis

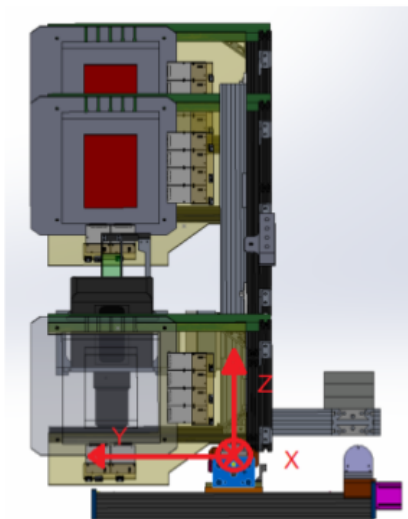

Using HRS hut coordinate system

- Origin defined at the center of the 5-inch travel (top) slider platform.

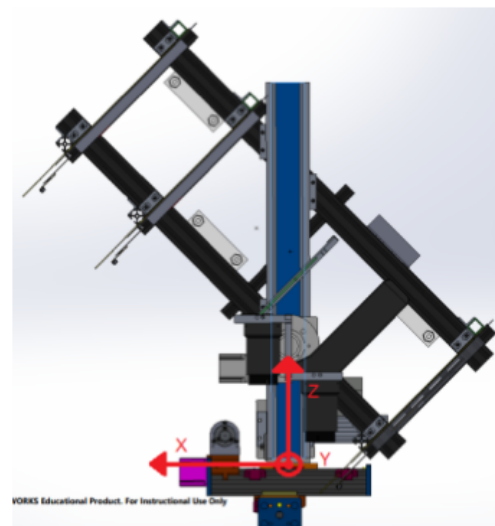

Center of Mass Analysis

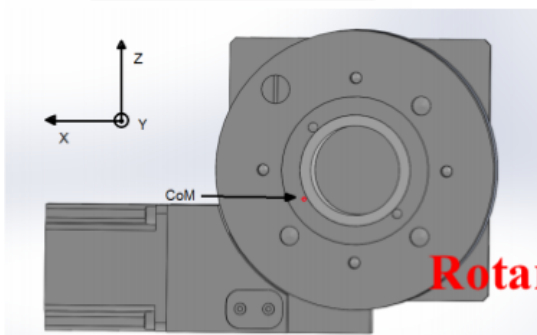

Rotary Stage

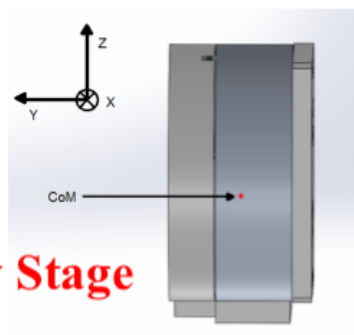

Tandem Det

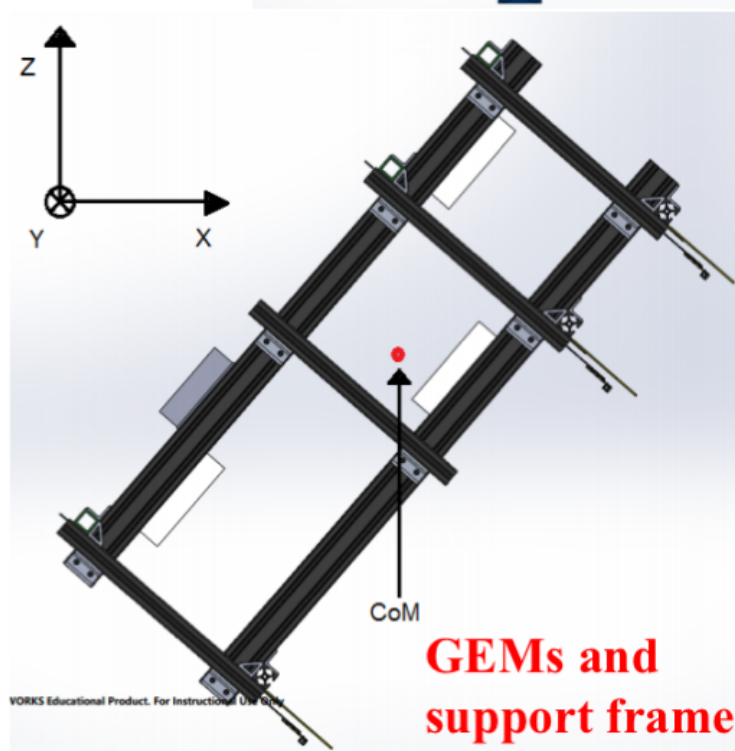
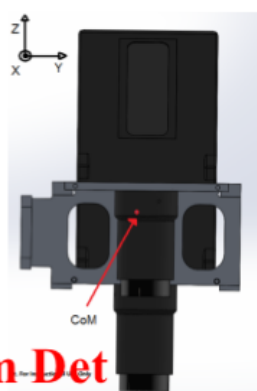

GEMs and support frame

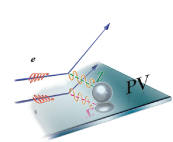

HRS Detector Package Torque Analysis

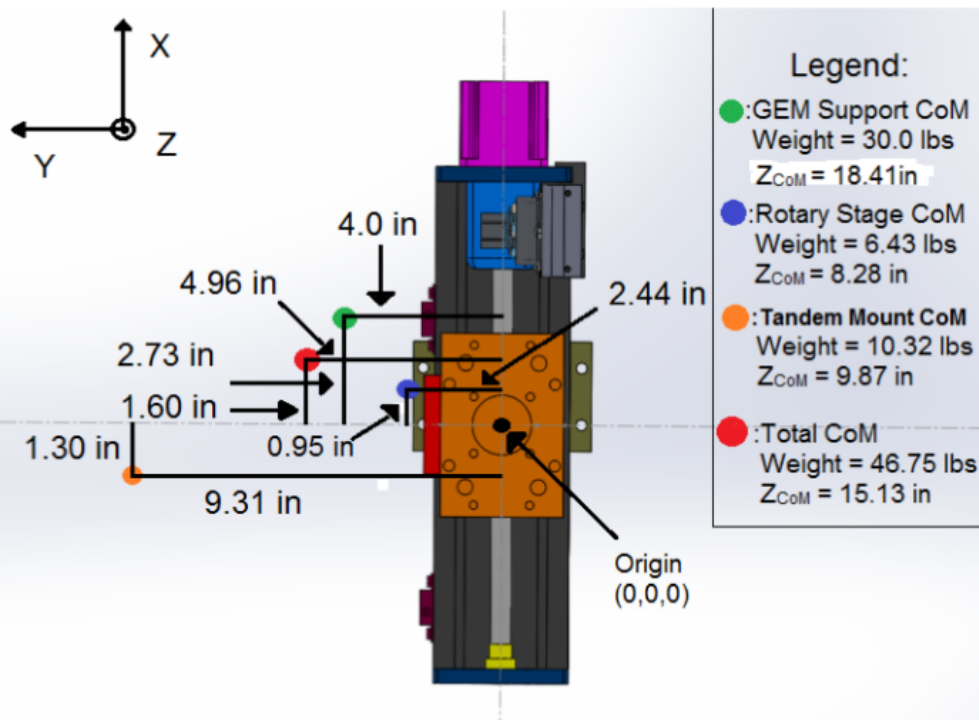

Dot Color	Assembly	Weight (lbs)	Torque around y-axis (in-lbs)	Torque around x-axis (in-lbs)
Green	GEM Support Frame	30.0	81.90	-120.0
Blue	Rotary Stage	6.43	6.11	-15.69
Orange	Tandem Quartz Mount	10.32	-13.42	-96.08
Red	Total Detector Package	46.75	74.59	-231.77

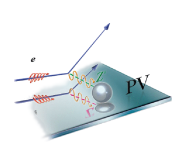

HRS Detector Package Torque Analysis

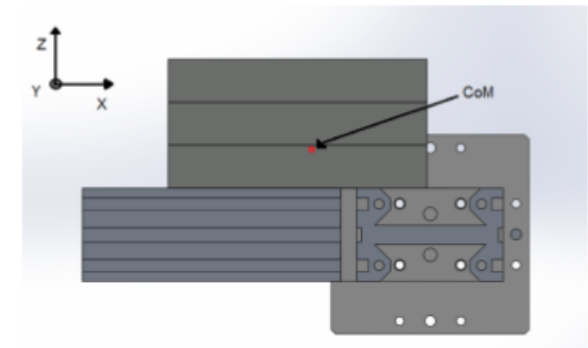
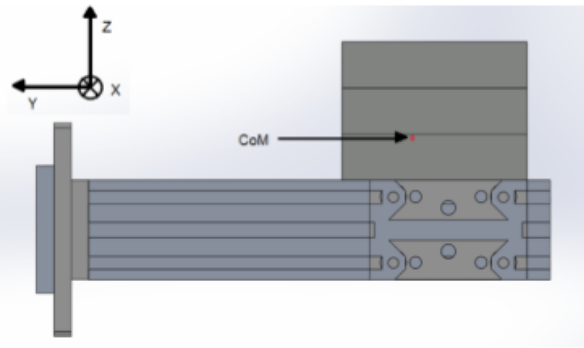
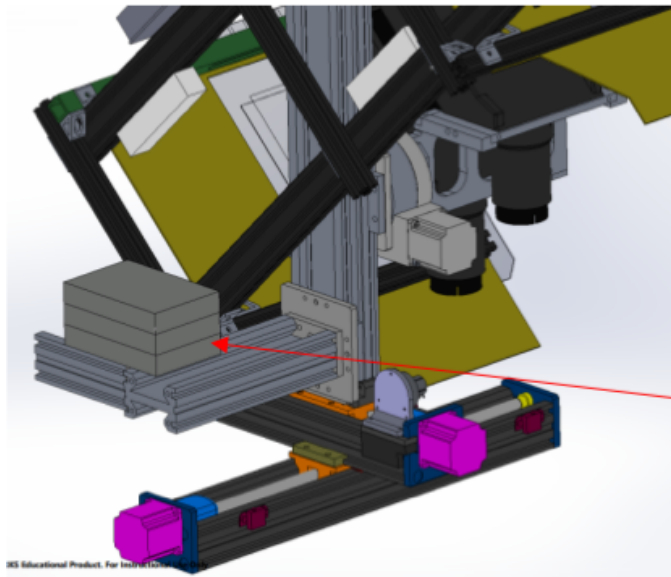

Counter weight (+ supports): 26.4 lbs

- Using the new center of mass location and new load (old load + counterweight) of **73.17 lbs**, net torques were calculated.
- Net Torque about X-axis:
 $(0.015 \text{ in}) * (73.17 \text{ lbs}) = \mathbf{1.10 \text{ in-lbs}}$
- Net Torque about Y-axis:
 $(0.026 \text{ in}) * (73.17 \text{ lbs}) = \mathbf{1.90 \text{ in-lbs}}$
- Net Total Torque:
 $((1.10)^2 + (1.90)^2)^{1/2} = \mathbf{2.19 \text{ in-lbs}}$

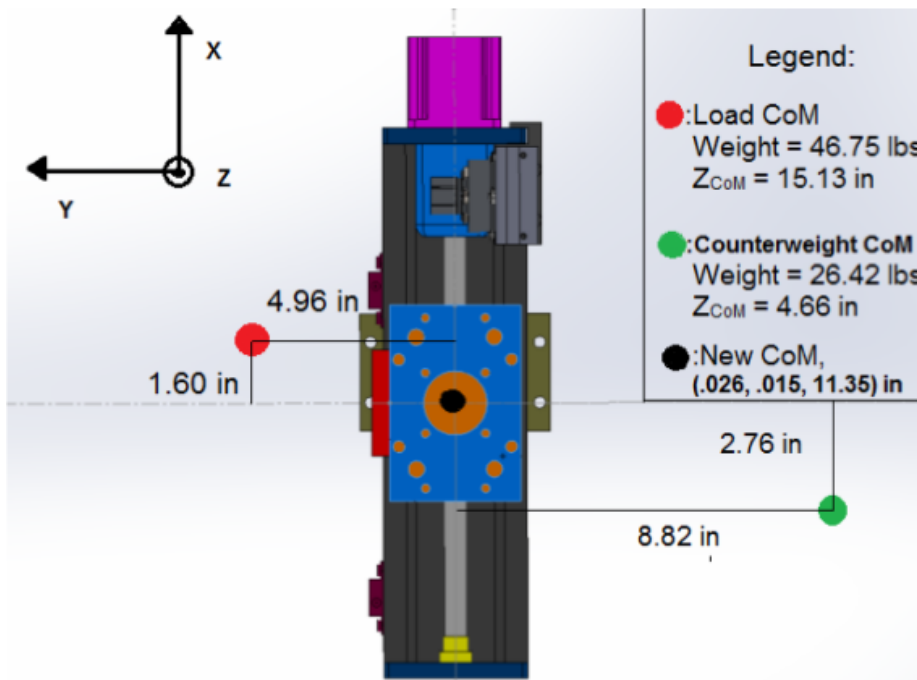

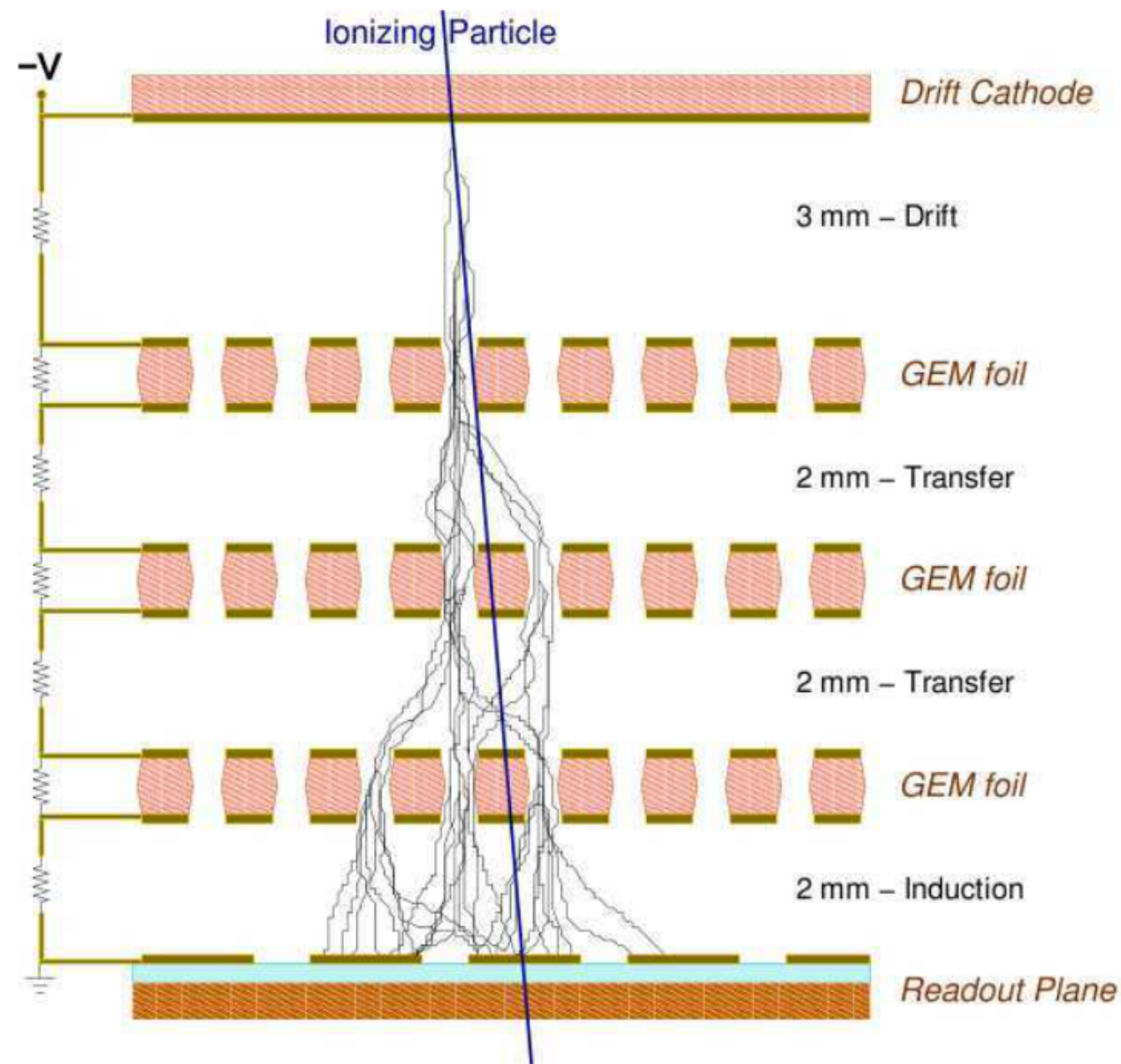
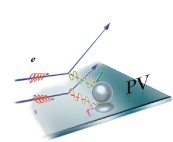

Triple GEM Chamber Operational Design

- Invented in 1997 at CERN by Fabio Sauli to support particle tracking needs of upcoming collider experiments (COMPASS,...)
- Gaseous Electron Multiplier: uses Ar/Co₂ mix (75/25)
- Each GEM foil gives factor of 20 – 25 gain: $20 \times 20 \times 20 = 8000$
- Made from very light/thin components
- Can measure particle positions at 100 micron level and operate at extremely high rates

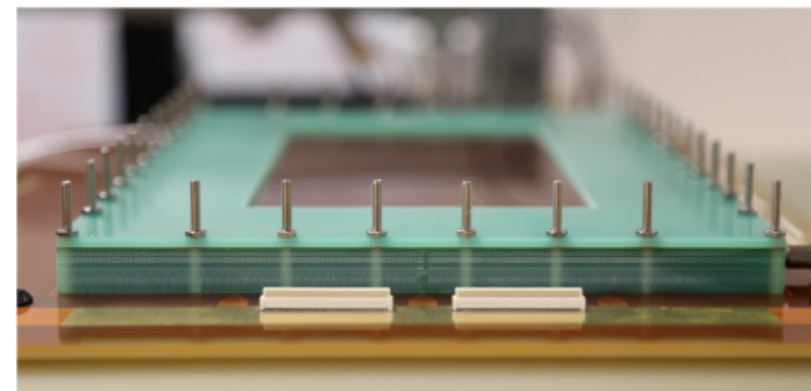

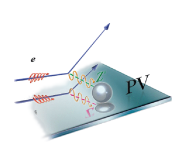

GEM Foil Design

GEM foil perforation pattern:

- Holes are 30 micron diameter, separated by 70 micron
- 5 micron Cu on top and bottom with 50 micron Kapton in between
- 400 V potential between Cu ends creates $\sim 100,000$ V/m E-fields in holes

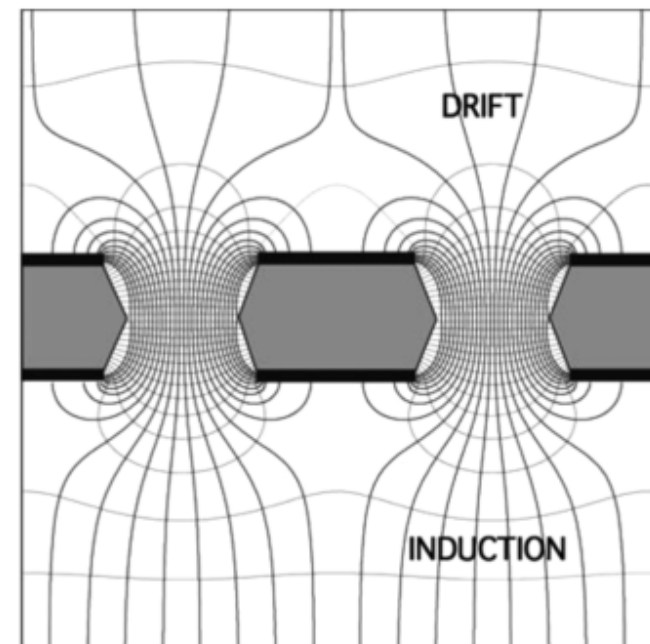
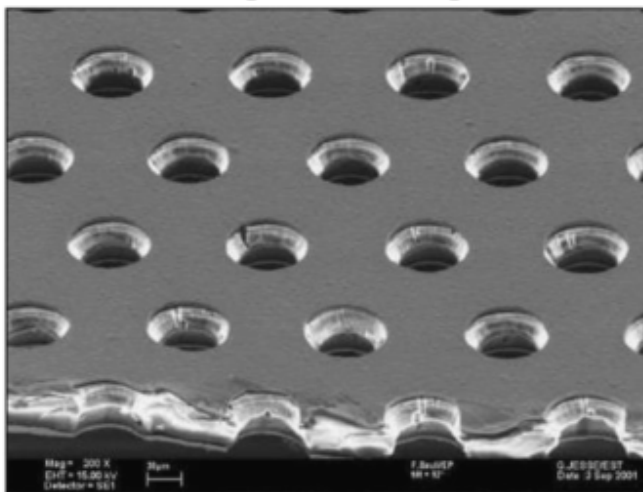
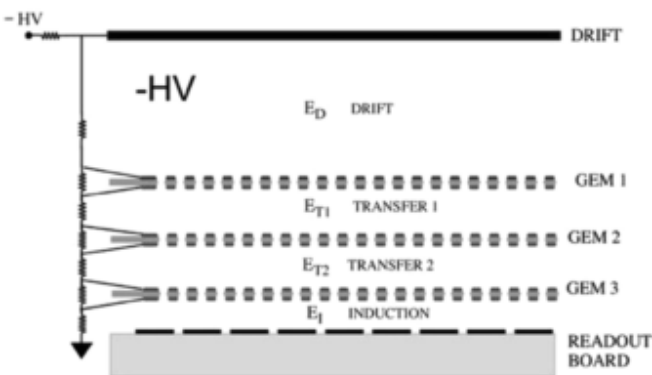

Hour glass hole shape

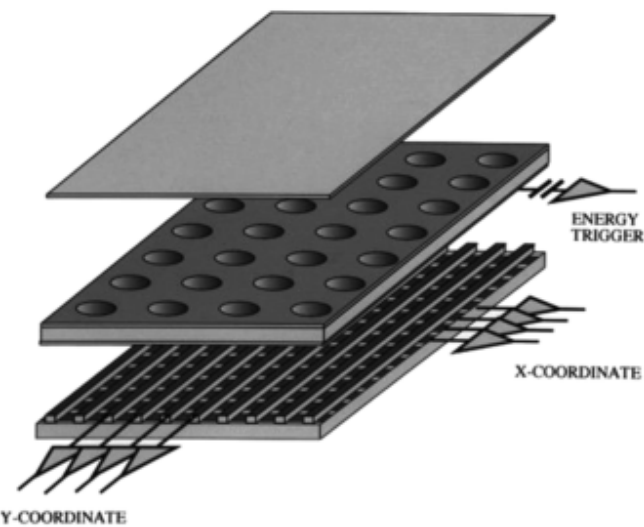
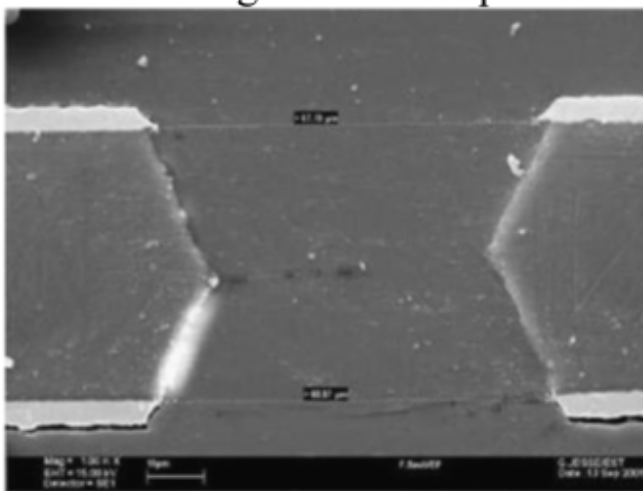

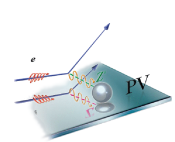

PREX/CREX “small” 10x20 cm² GEM trackers

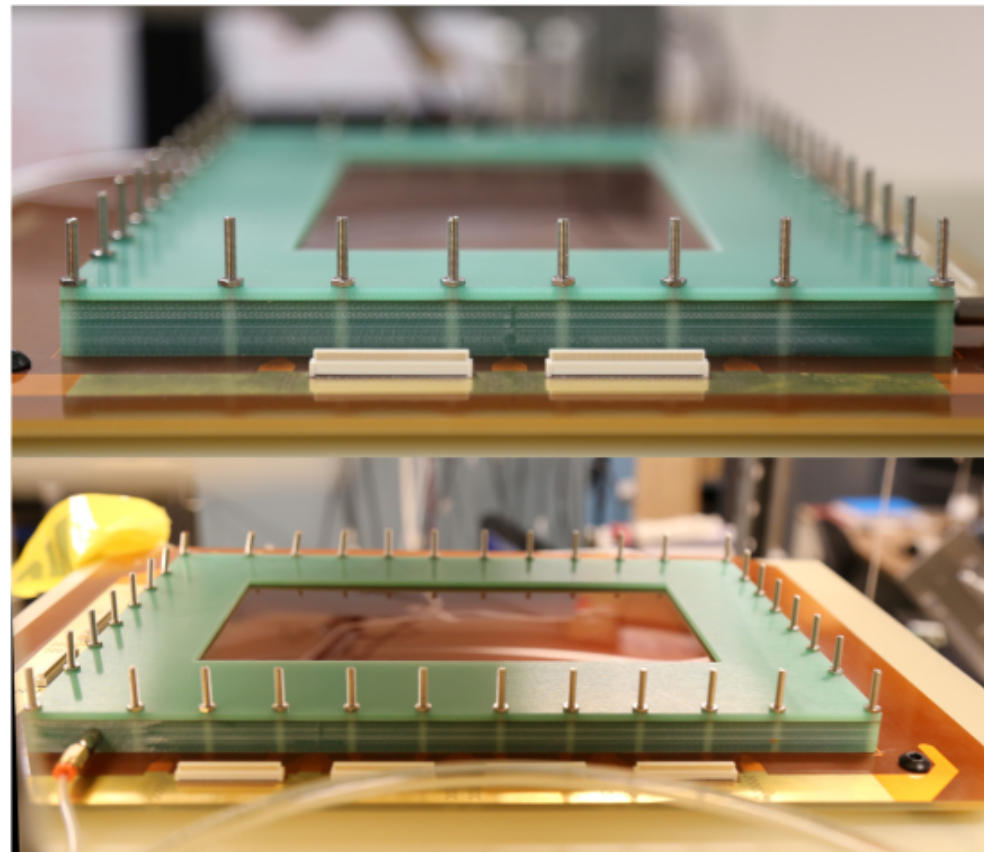
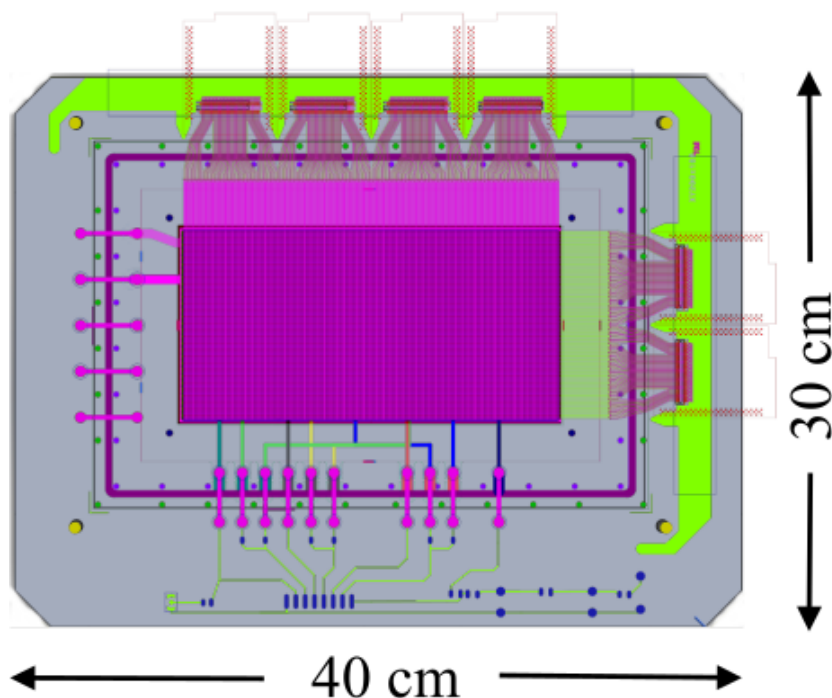

- Custom CERN 10 cm by 20 cm active area triple GEM chambers
 - 400 μ m pitch x/y, 4 + 2 Panasonic 130pin Readout connectors
 - Standard GEM spacing D-3mm-G1-2mm-G2-2mm-G3-2mm-RO
 - Standard HV filter circuit: uses CERN ceramic resistor
- Readout scheme based on INFN/UVA SBS rear-tracker:
APV25FE \Rightarrow backplane PCB \Rightarrow VME MPD

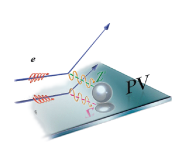

GEM Readout Plans

- GEM readout scheme based on INFN/UVA SBS rear-tracker system:
 - Uses APV25FE rev4.1 cards (have 55 in-hand); each chamber requires 6 APVs
 - Requires new 4-slot and 2-slot "backplane" PCBs (have 36 in-hand)
 - Backplanes buss analog-out signals to MPD and pass digital ctrl signals to APVs
 - Have 6 VME MPDs (Multi-Purpose Digitizers); require 2 for each arm
 - Uses fast intel Linux ROCs (have 3 in-hand: GE XVB601); require 1 for each arm

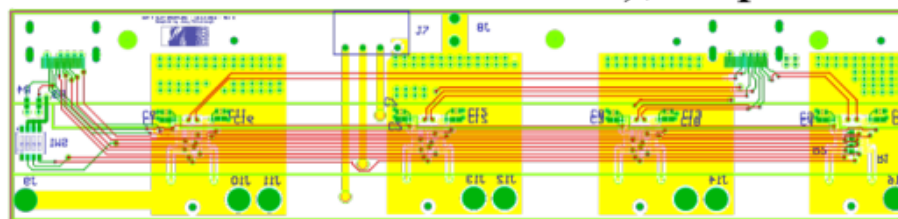
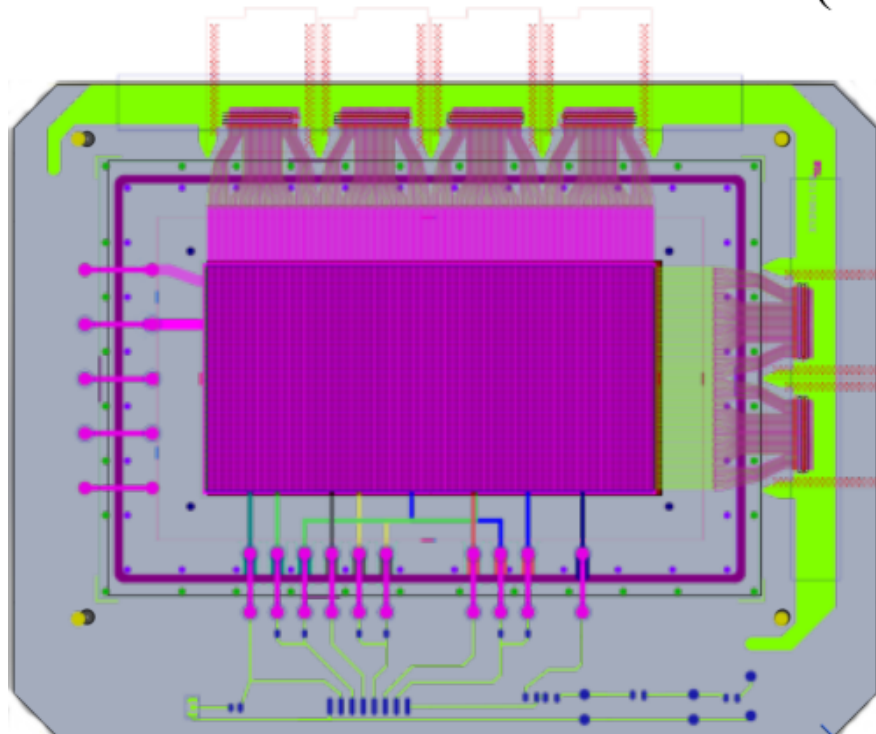

4-slot backplane



APV rev4.1

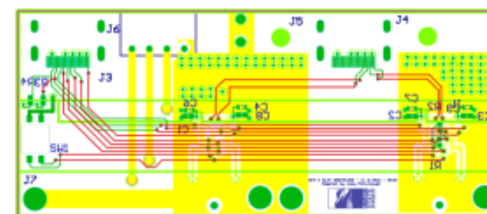

2-slot backplane

APVs mount directly to Panasonics on GEM readout board—amplifies and multiplexes output



MPD rev4:
Handles 16 APVs

❖ Getting much advice and help from Paolo Musico and INFN group, Kondo Gnanvo, Chris Cuevas, Nilanga Liyanage, and Alexandre Camsonne

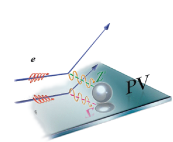

GEM PCB Gerber File Render

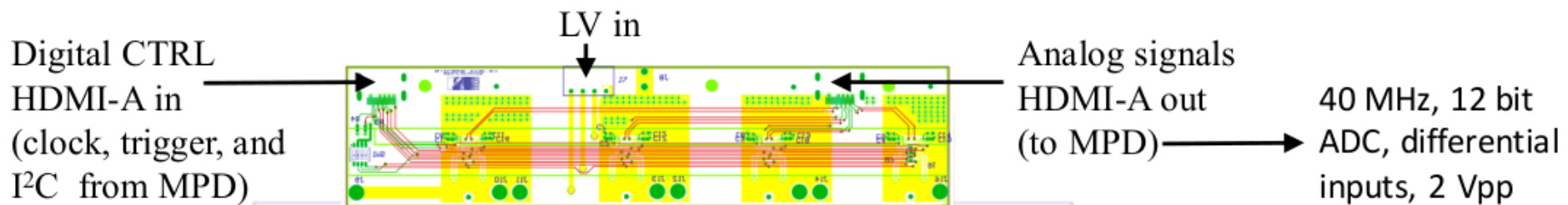

125 x 4 = 500
channels for
dispersive (x)
direction

750 x/y channels
per chamber
gives 3000
channels per arm

Each MPD can
handle up to
2000 channels;
Jlab DAQ group
support for
CODA drivers
and readout list

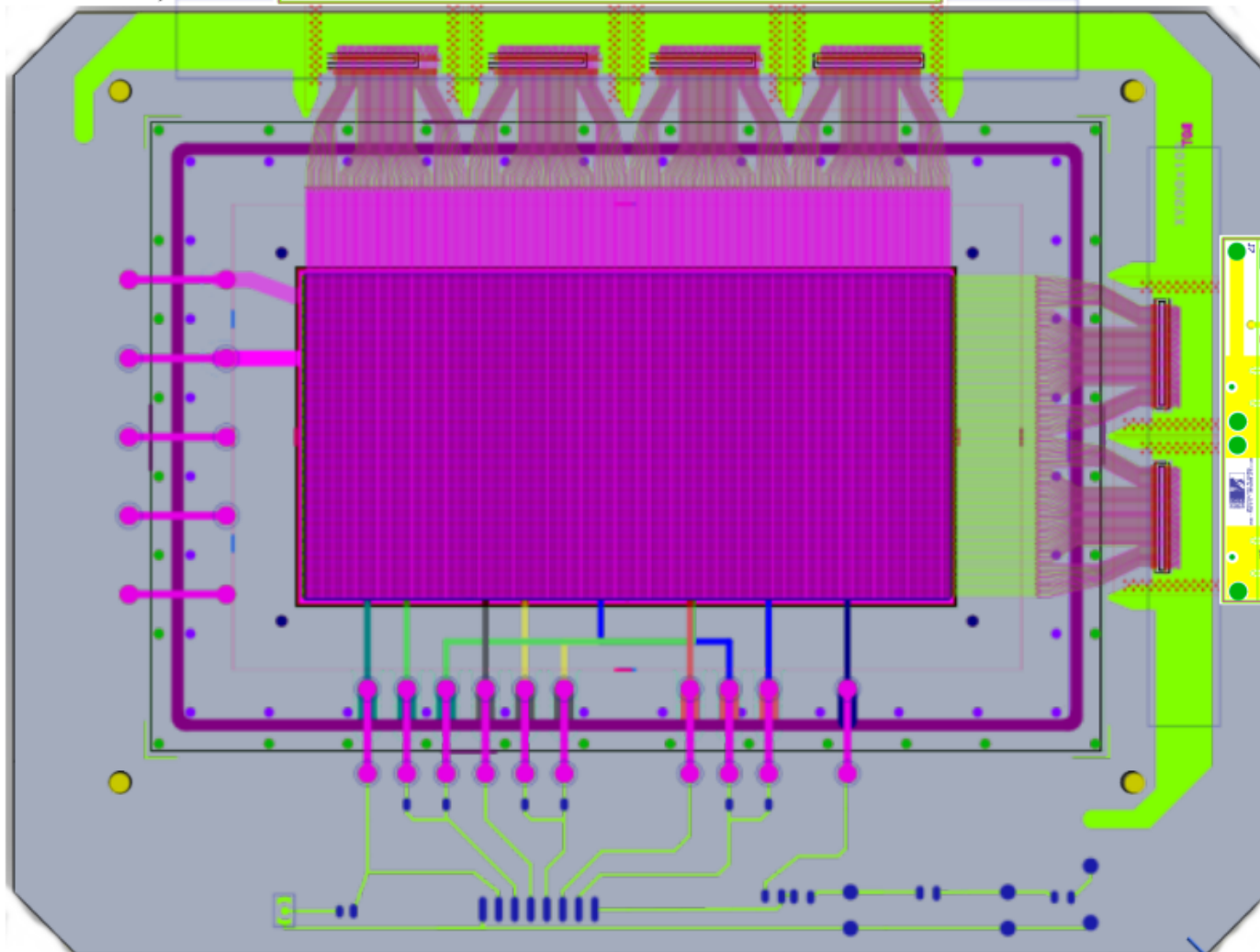

125 x 2 = 250
channels for
transverse (y)
direction

Use analog
patch panels to
combine
signals from
two 2-slot
backplanes –
allows for
efficient use
of MPD
inputs

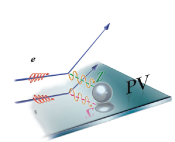

GEM Support Frame

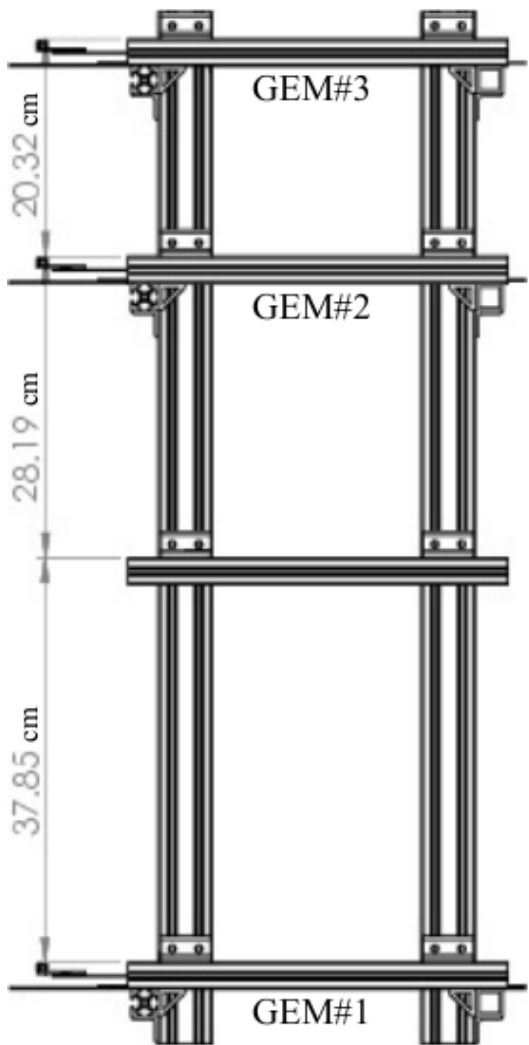

Aluminum ladder-frame

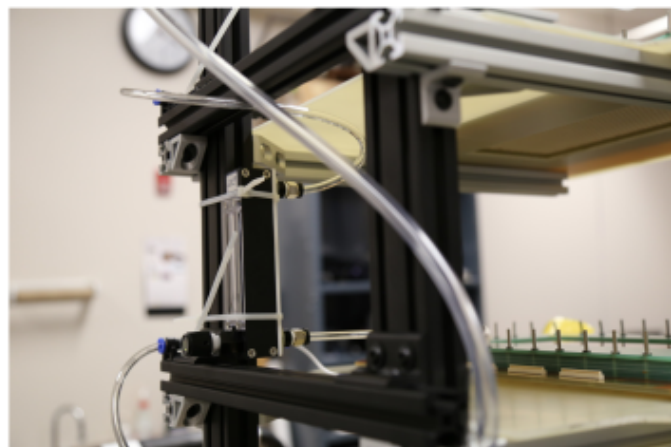
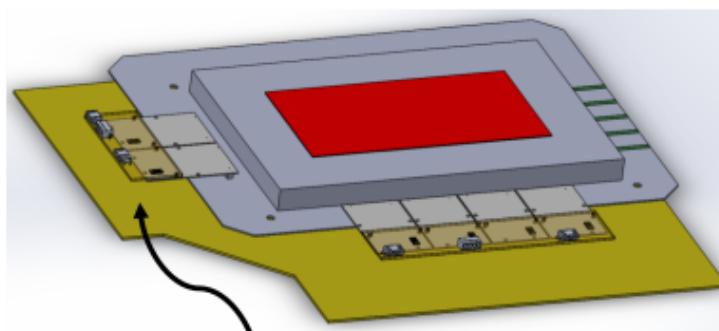
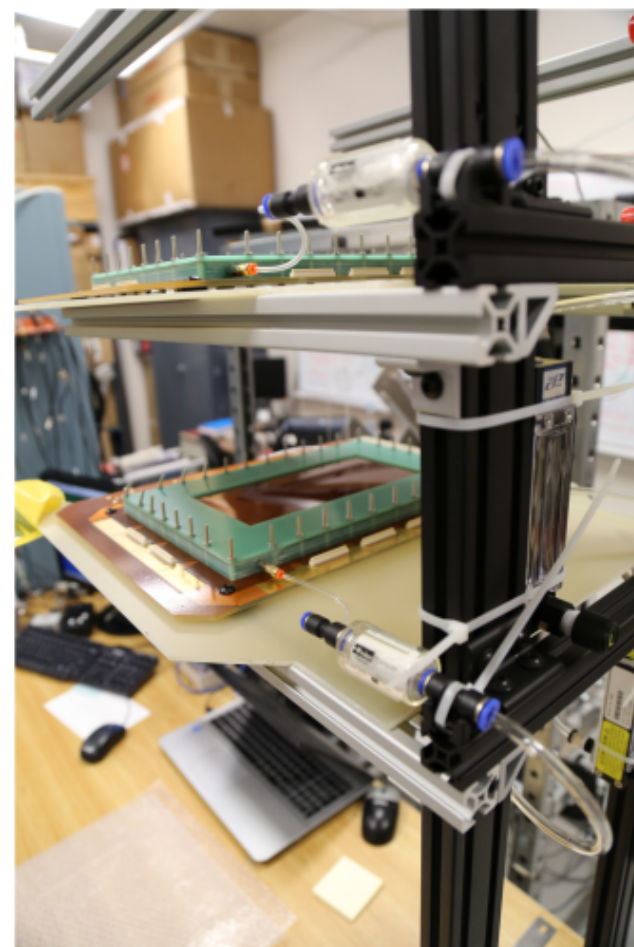

Photo showing rail support brackets



G10 platforms (1/16 in. thick) for GEMs: supports readout electronics



Two Chambers installed; gas flowing

- 1" Extruded aluminum framing system for GEM mount
- Each arm uses three GEM chambers: one upstream and two downstream of quartz det
- GEM ladder-frame mounts to Velmex slider post using cleats

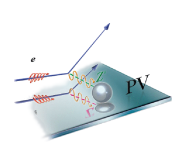

Cosmic Test Stand

Rotary Stage

PREX detector cover

PREX tandem rotary
mount

HV divider
circuit

4-slot backplane card

APV25 FE cards (6 total per GEM)

2-slot backplane card

Low Voltage Input

HDMI digital ctrl (from MPD)

HDMI Analog signal out (to MPD)

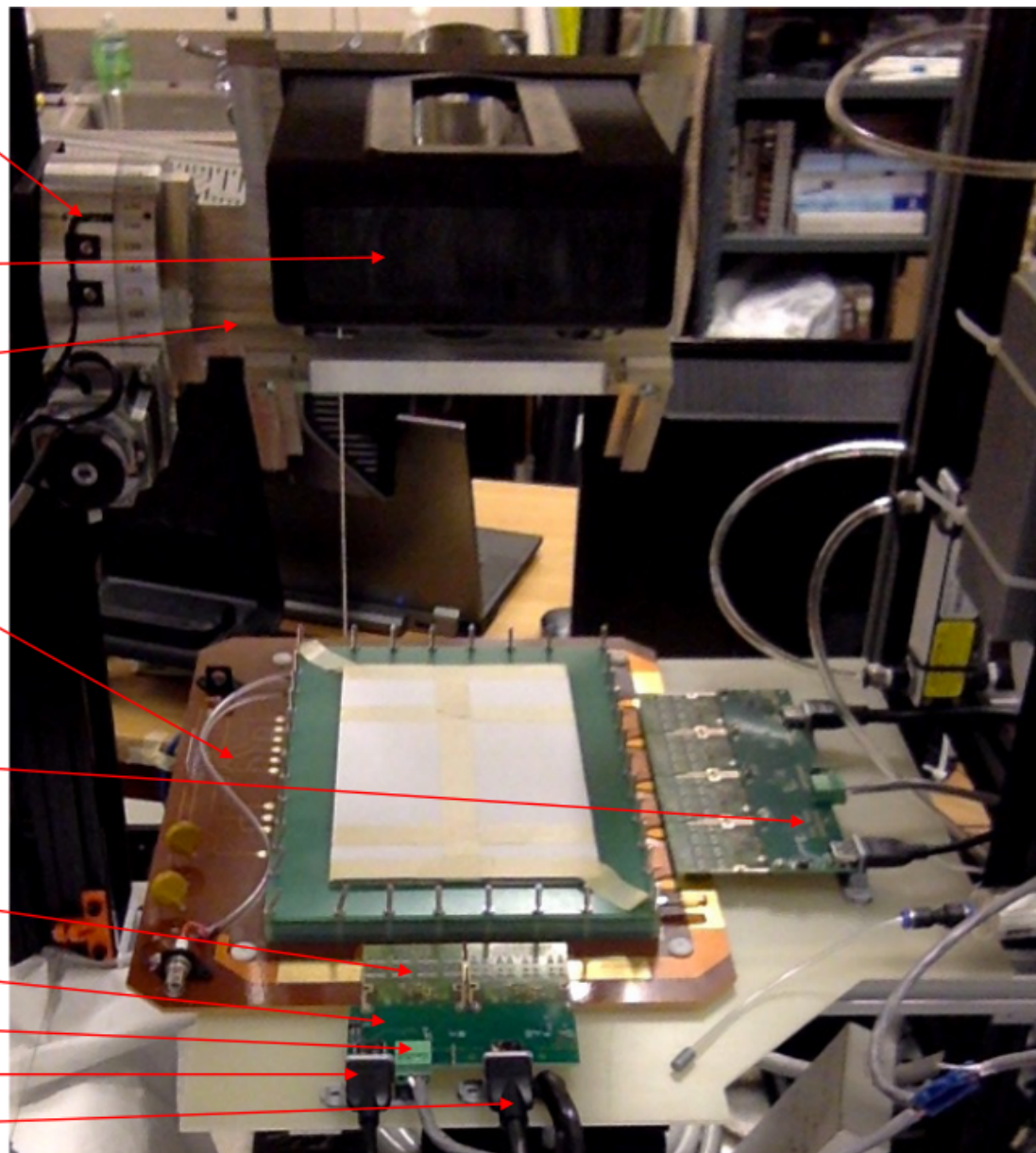

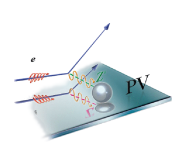

VME Crate for ISU GEM DAQ

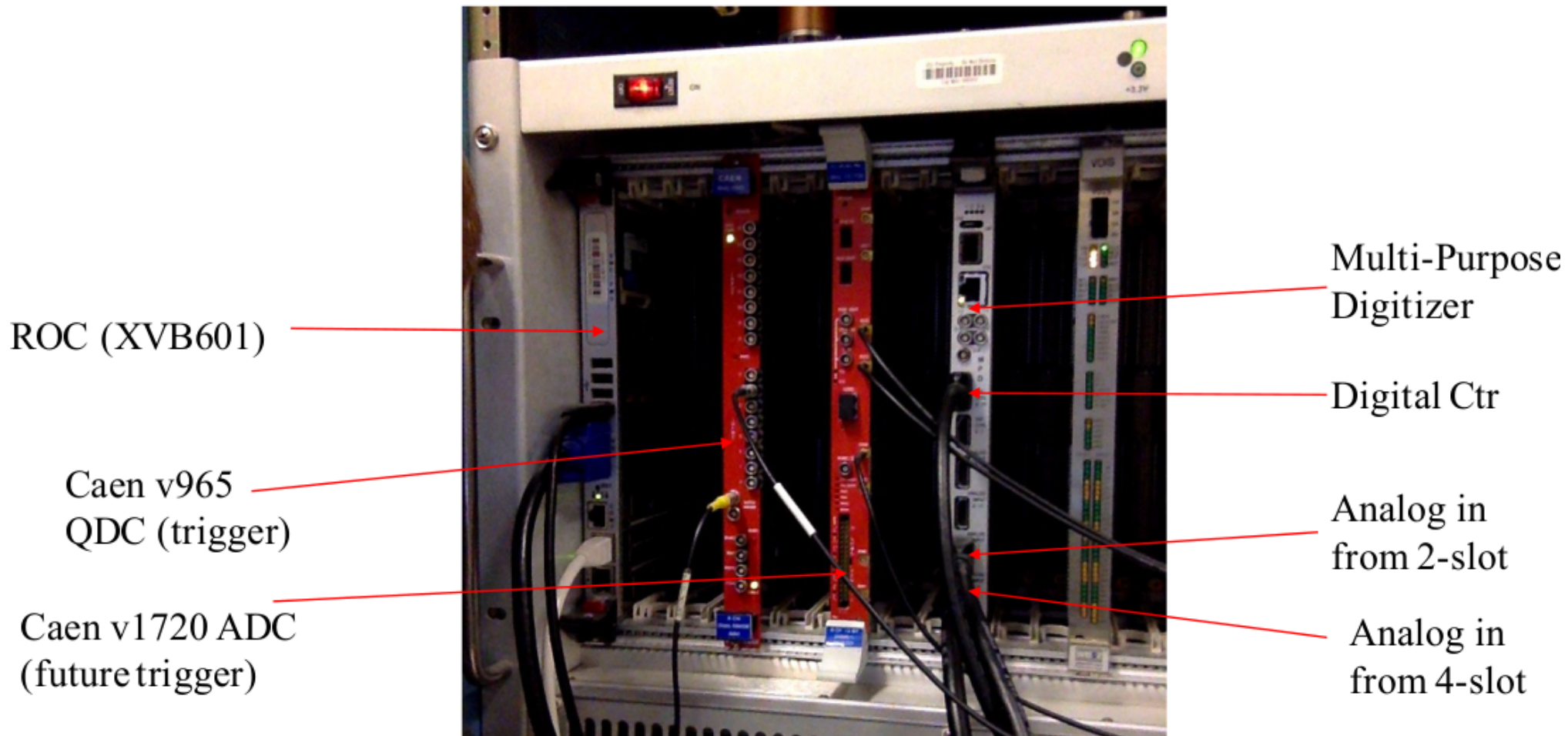

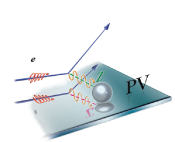

PREX-II/CREX Main Detector Package

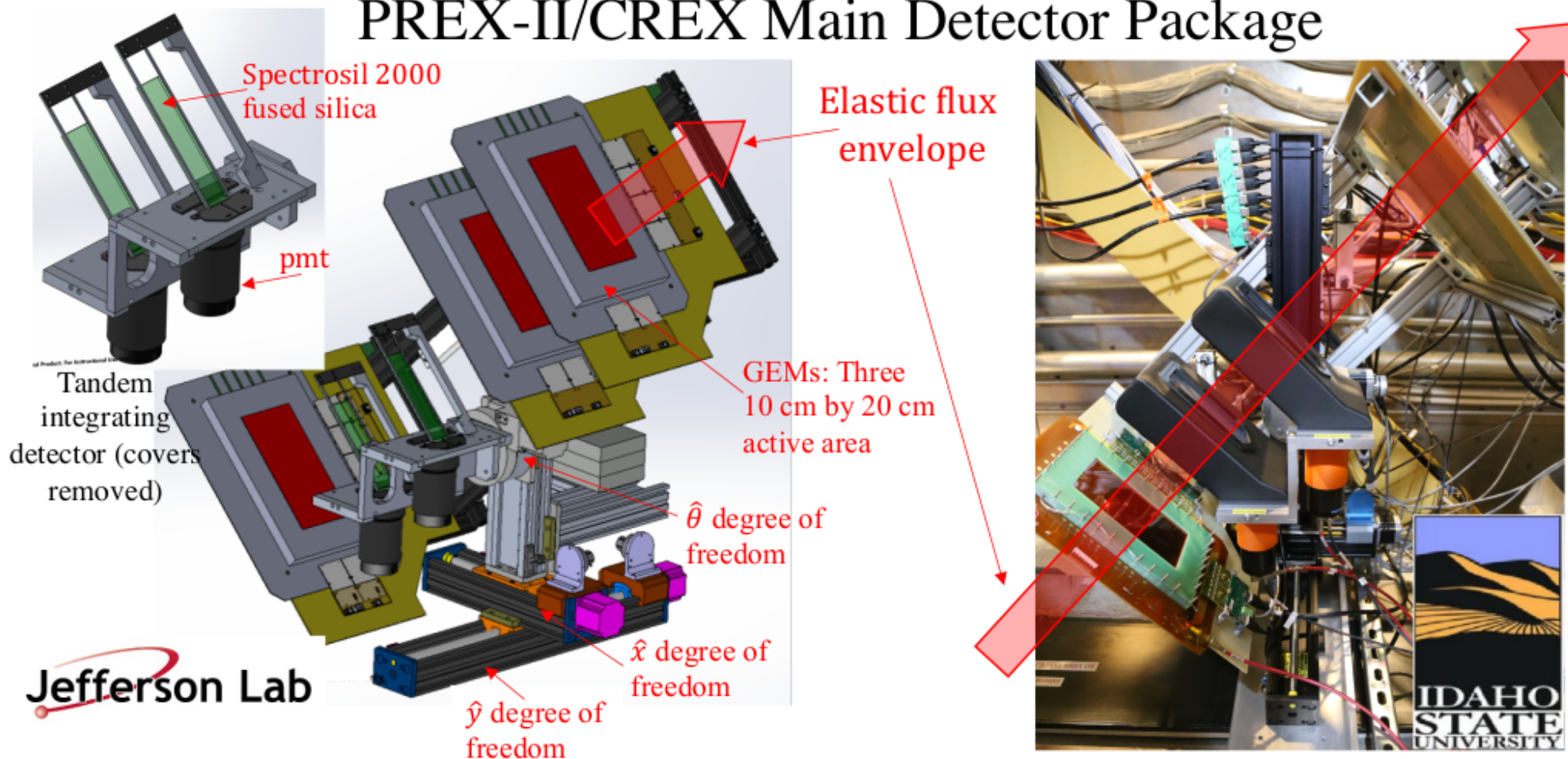

 Jefferson Lab

- PREX-II took place over summer 2019 and completed successfully in early September 2019
 - Measured ~ 0.5 ppm A_{PV} from ^{208}Pb with ~ 1 GeV beam at $5^\circ \theta_{\text{lab}}$ to $\sim 3\%$ stat. precision
 - Integrated flux rates were >2 GHz per arm (Left and Right HRS); 26% detector resolution
 - Achieved 14 ppb statistical precision with a few nanometer control on beam positions
 - GEMs operated at 95% efficiency; provided precision Q^2 avg and systematic checks
 - Overall systematic error well below 14 ppb; extracted neutron skin to ± 0.08 fm precision

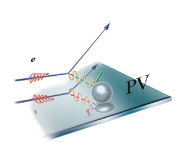

PREX-II/CREX Main Detector Package

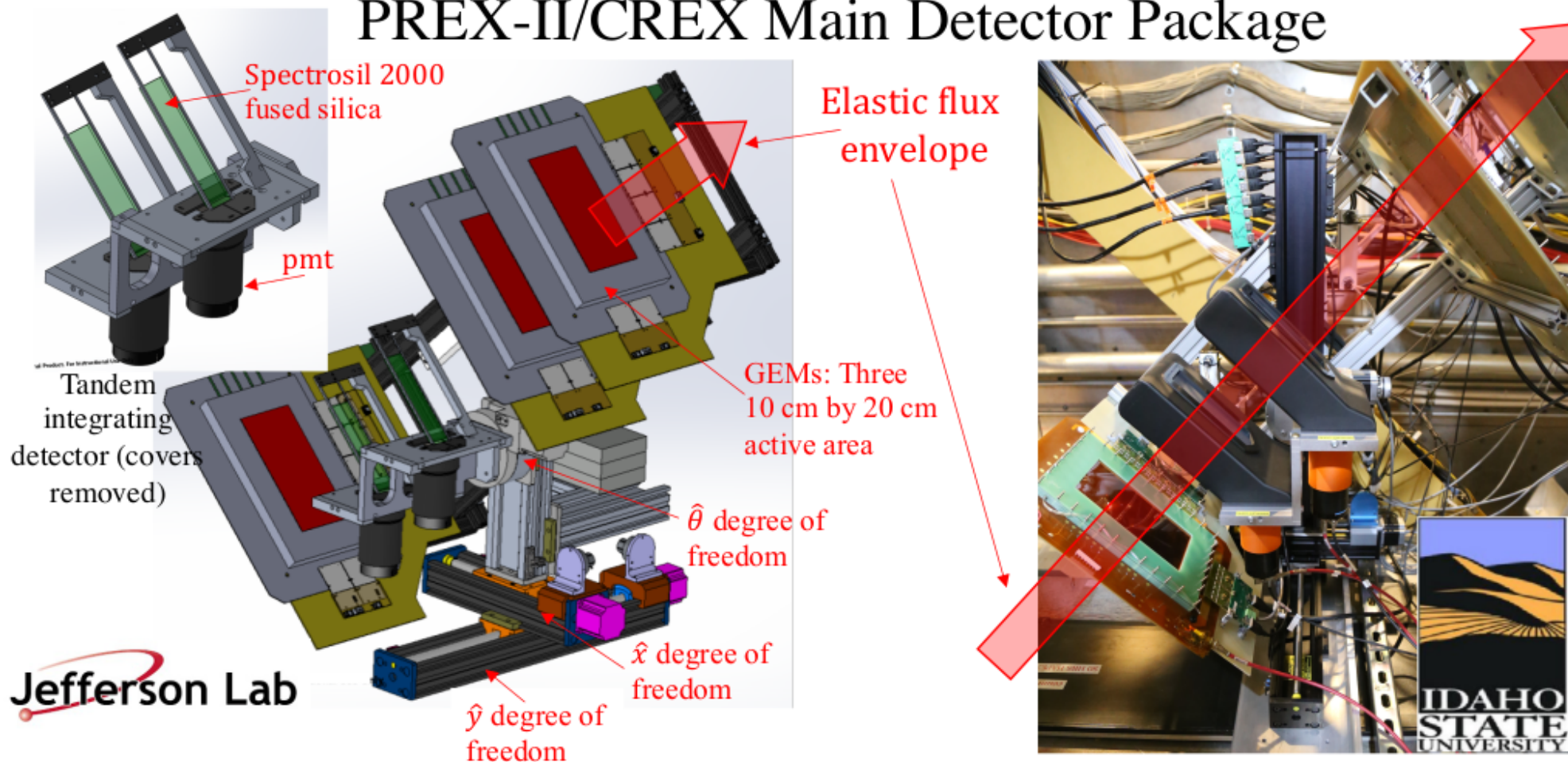

 Jefferson Lab

- CREX (Calcium Radius Experiment) ran from Dec 2019 to Sep 2020 in Hall A, JLab
 - Measured ~ 2 ppm A_{PV} from ^{48}Ca with ~ 2.2 GeV beam at $5^\circ \theta_{\text{lab}}$ to $\sim 4\%$ stat. precision
 - Integrated flux rates are ~ 30 MHz per arm (Left and Right HRS); 26% detector resolution
 - 80 ppb (achieved) statistical precision with a few nanometer control on beam positions
 - Overall systematic error contribution 1.6%; measured the neutron radius and skin with ± 0.025 fm precision; result released on Oct 12, 2021; publication early next year.

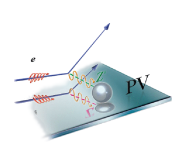

Examples of Focal Plane, Elastic Peak Spectra

Projected x on detector plane (run2652)

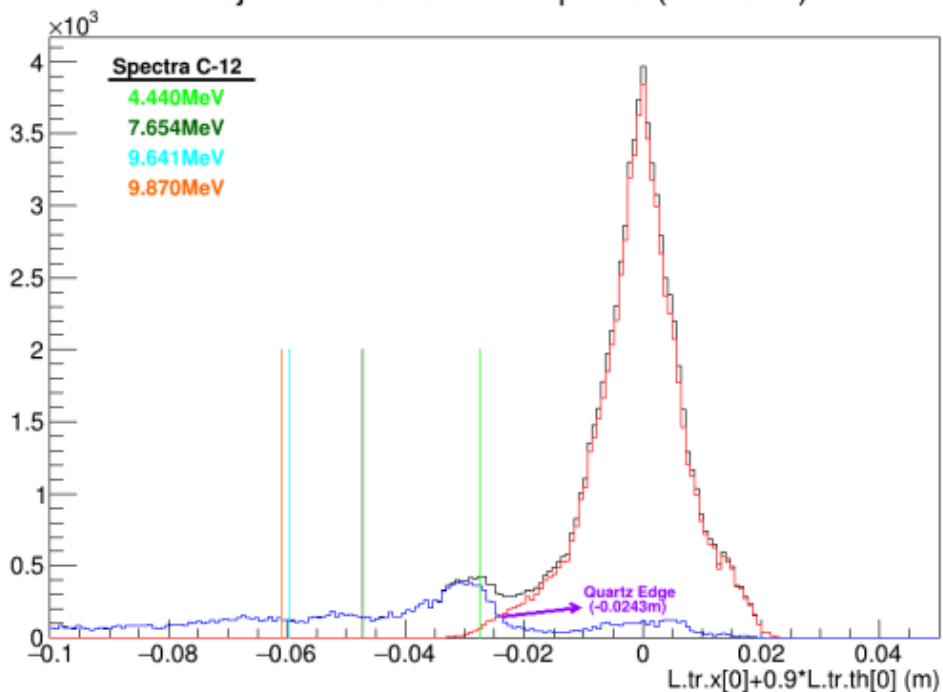

- HRS dispersion: 14.3 cm / % dp/p at det. plane
- At 1-pass (2.183 GeV), this corresponds to ~ 6.57 mm elastic-peak shift per MeV change
- **Energy lock** with full-scale slow drift stability of 0.4 MeV (1.8×10^{-4}) provides ± 1.3 mm stability in peak position

- CREX has established its HRS tune giving expected rates and Q^2 (FOM)

Projected x on detector plane (run2649)

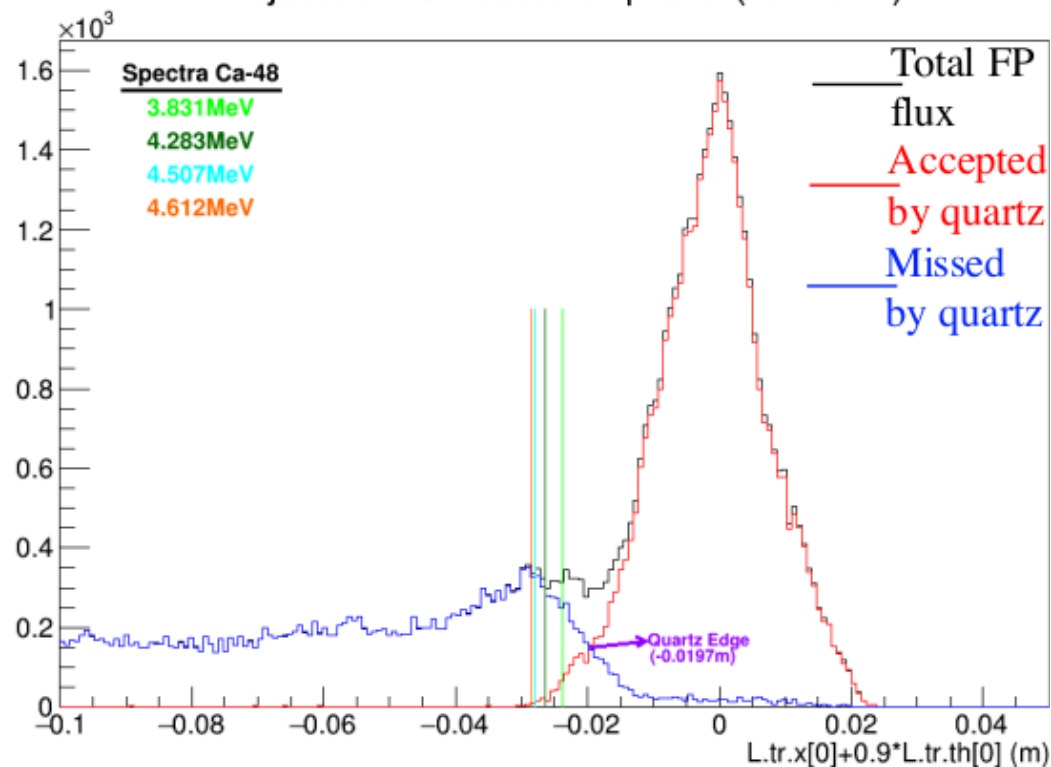

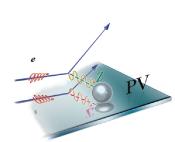

Detectors

PREX Optics Schematic

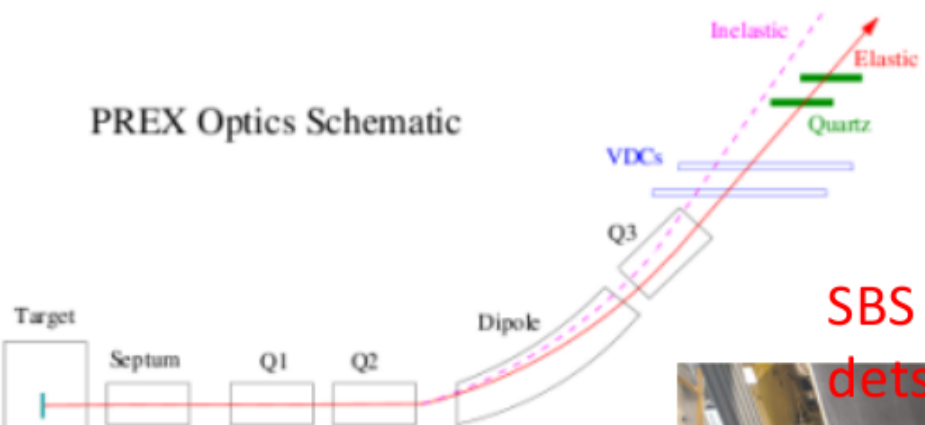

SBS GEM
dets

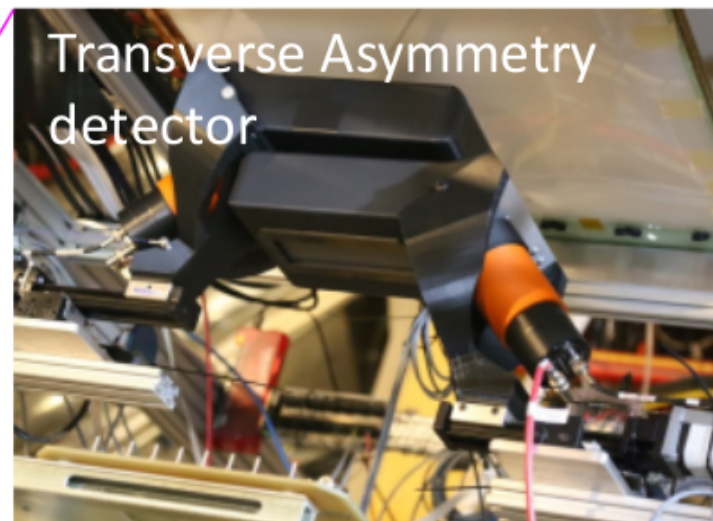
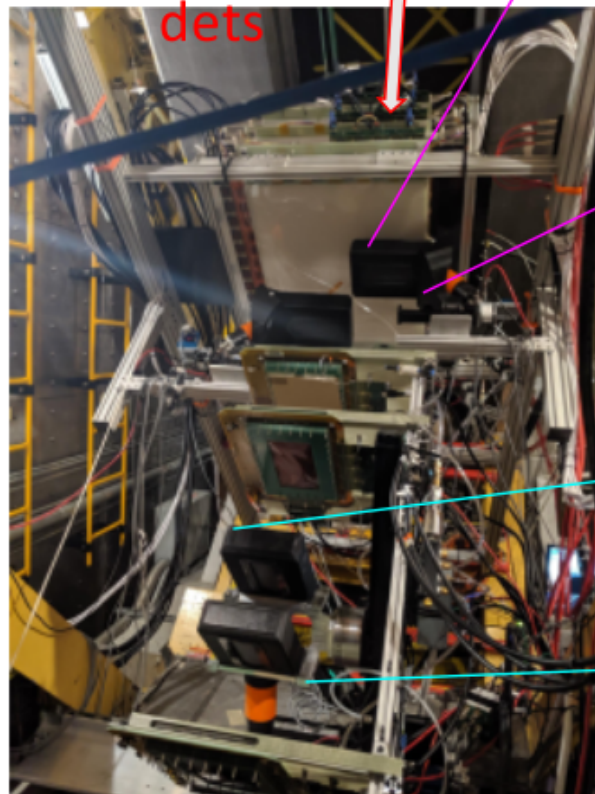

Projected x on detector plane

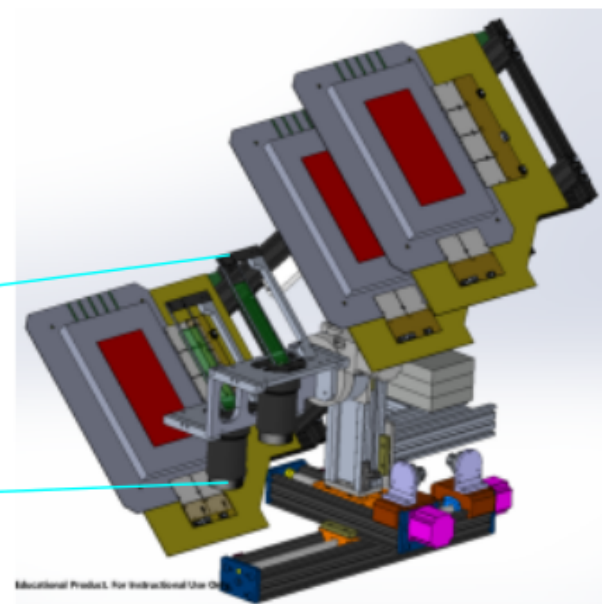
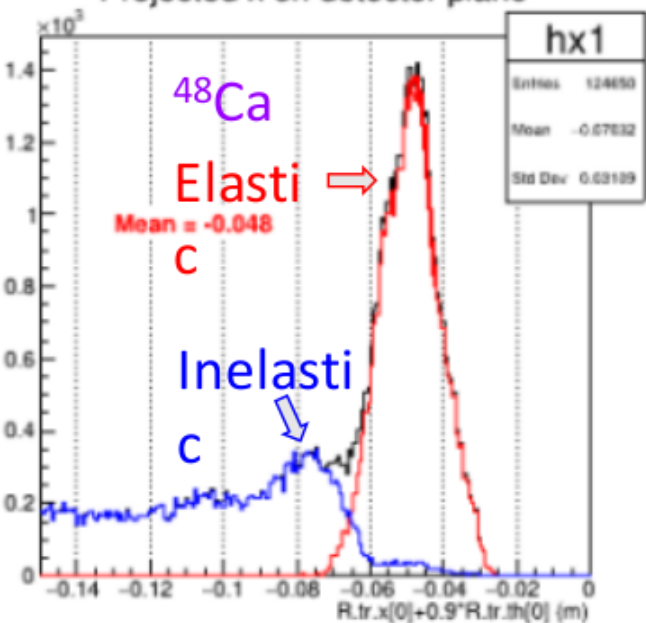

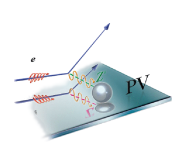

GEM Readout Operation

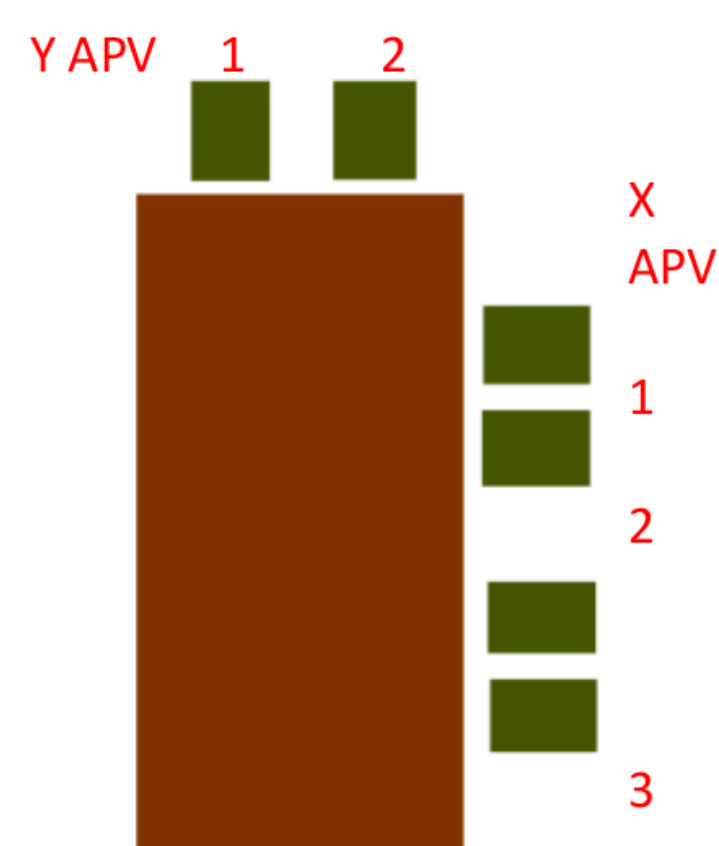

Schematic of one GEM Detector

Only three samples/strip



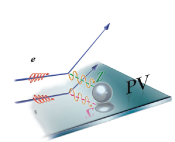

GEM Readout Operation

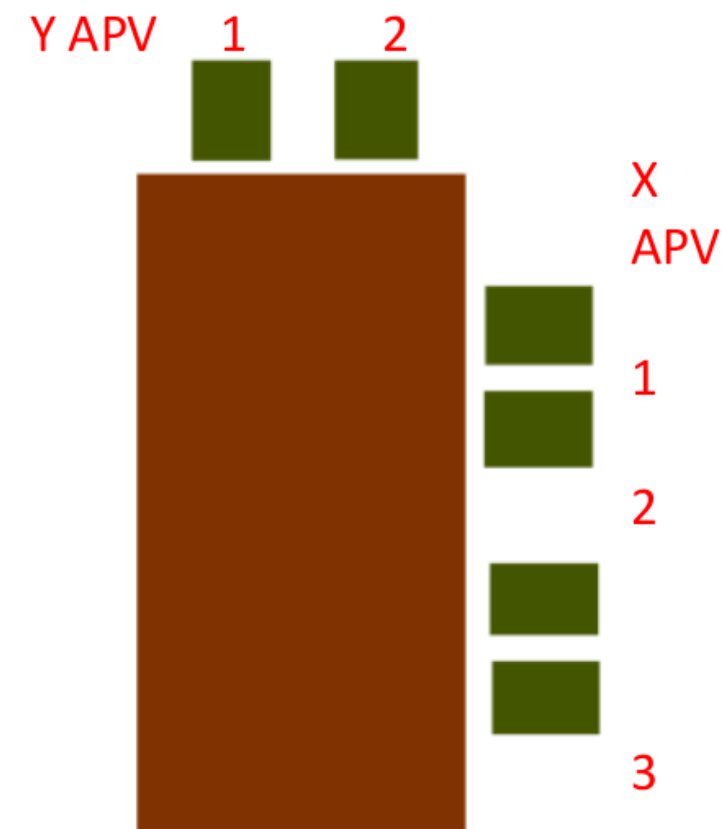

Schematic of one GEM Detector

Only three samples/strip

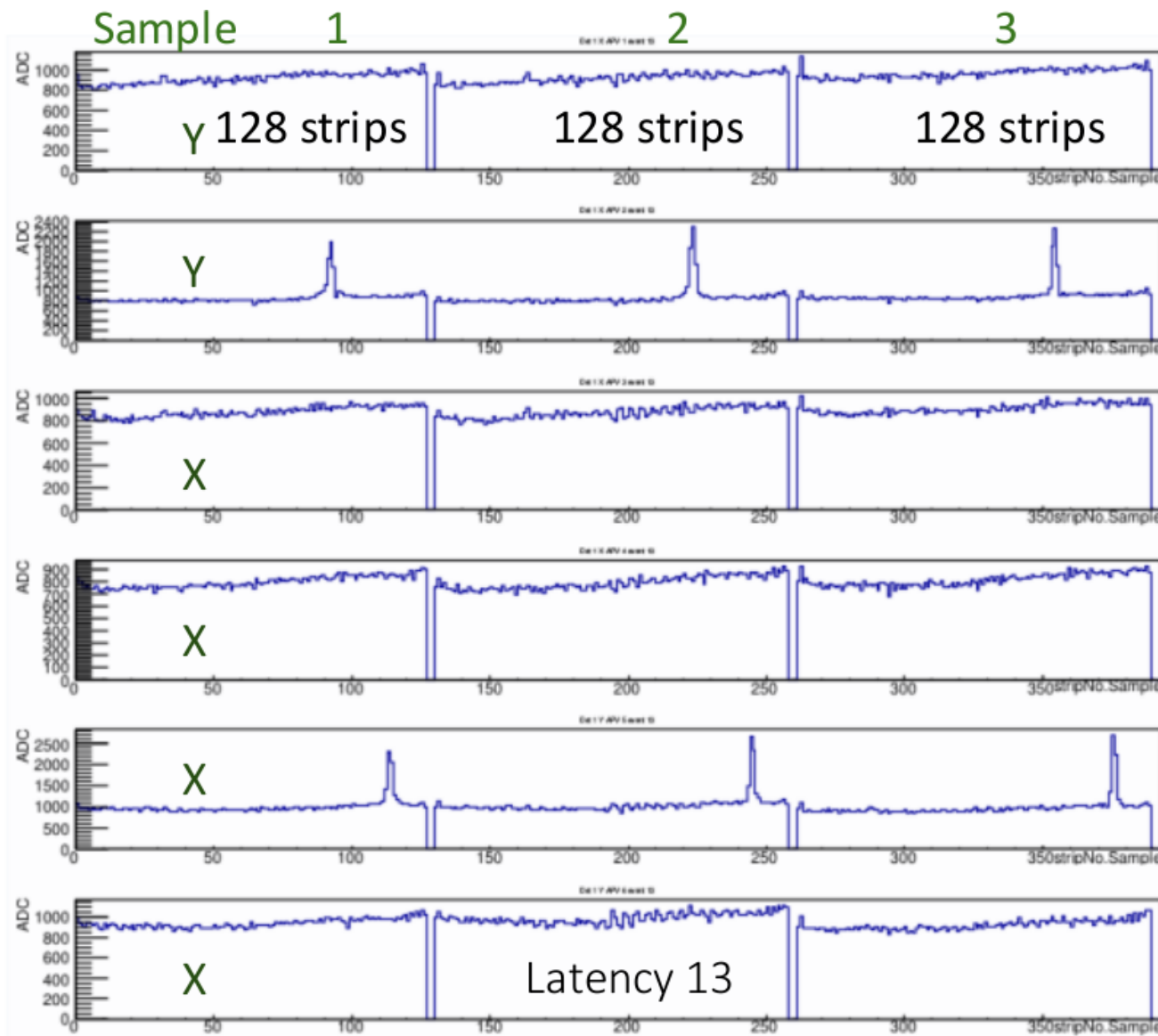

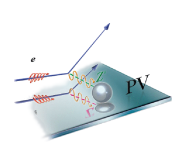

GEM Readout Operation

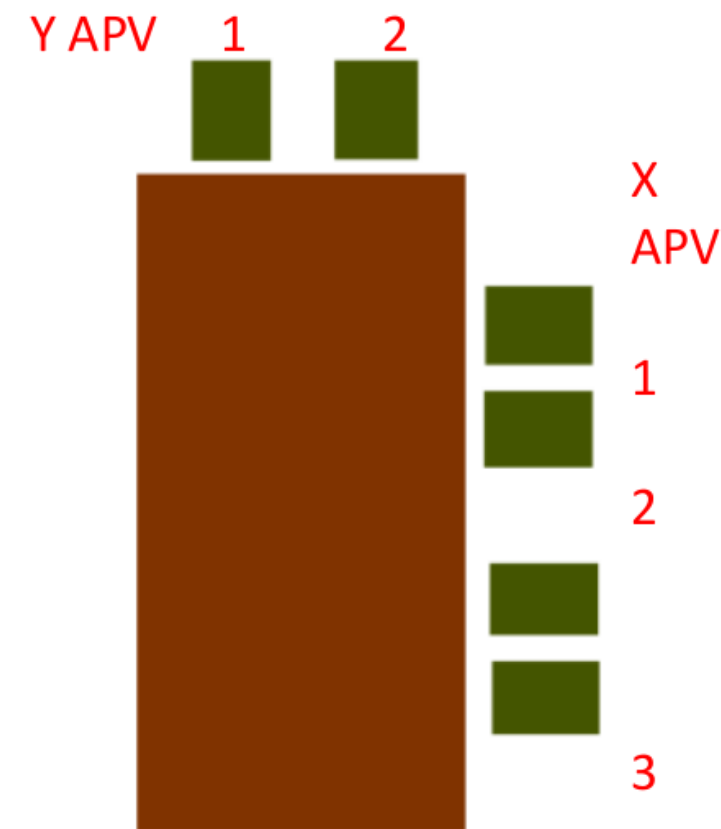

Schematic of one GEM Detector

Only three samples/strip

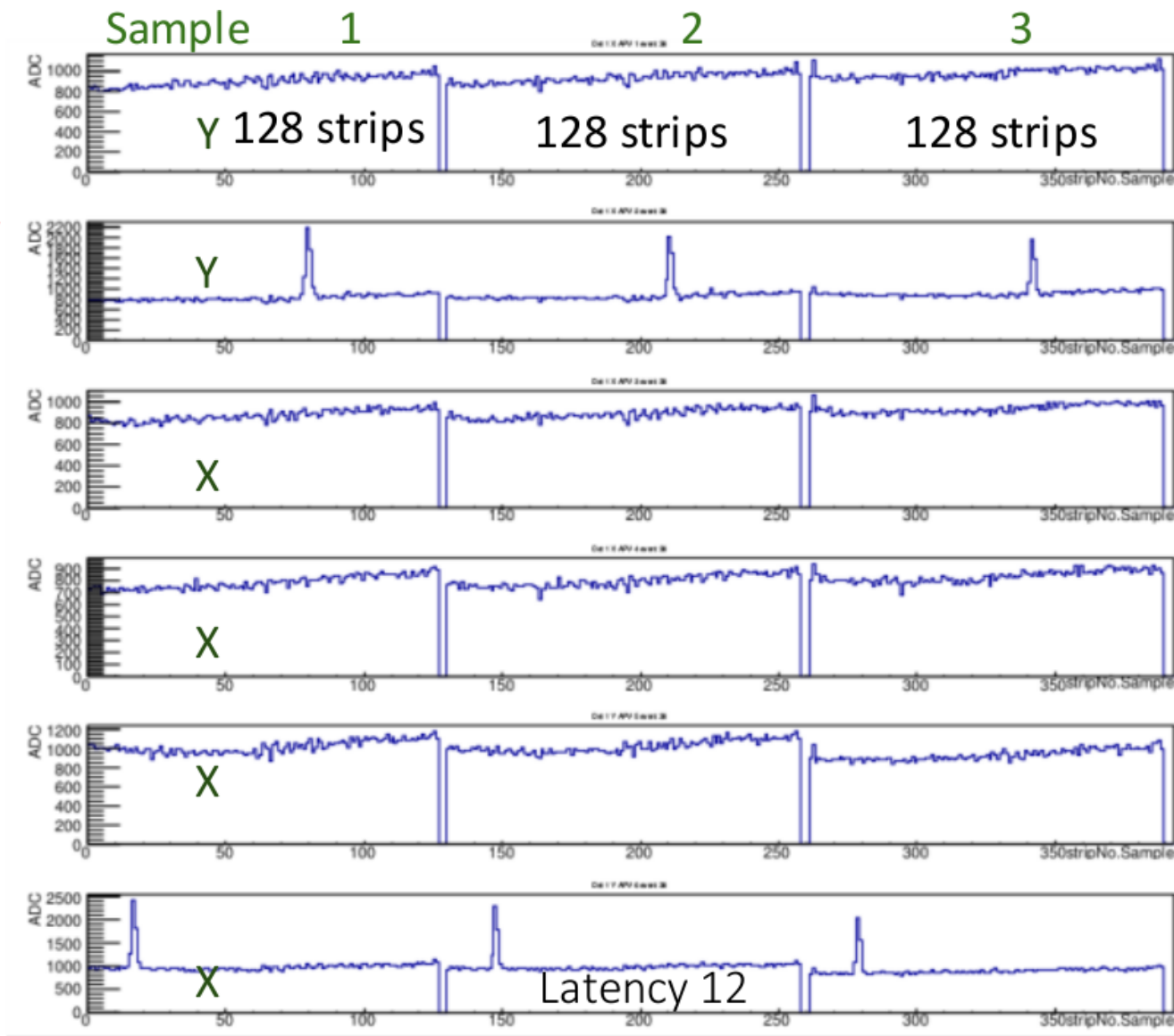

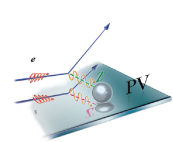

GEM Readout Operation

Charge correlation between two planes

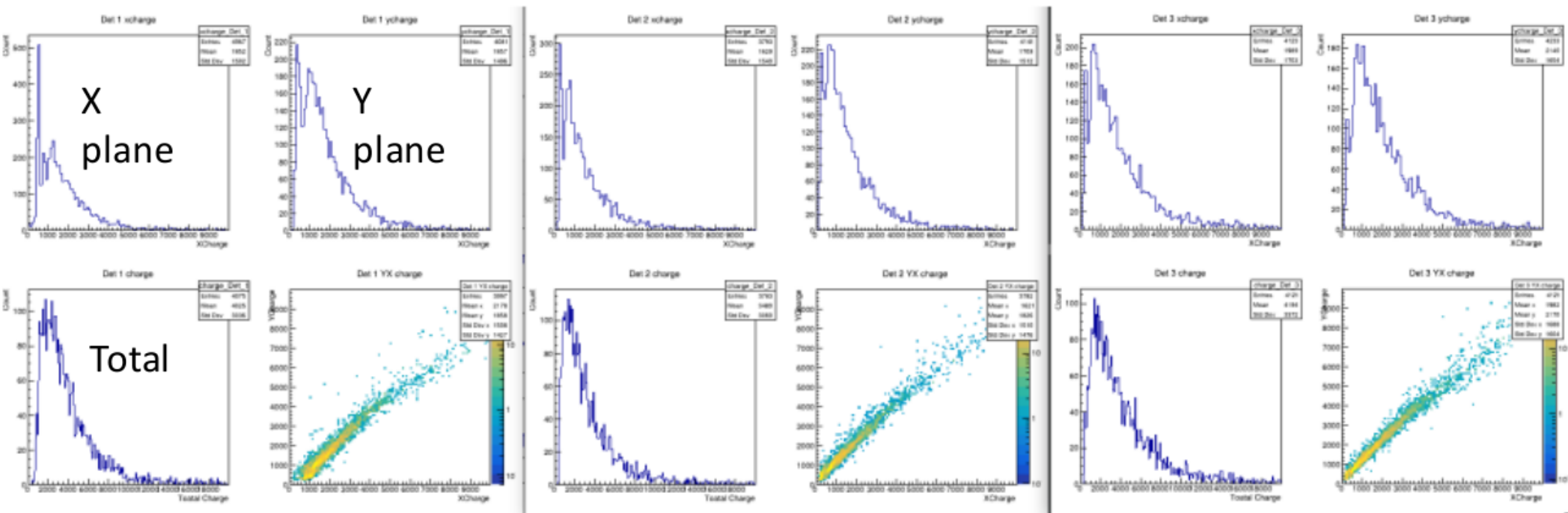

GEM 1

GEM 2

GEM 3

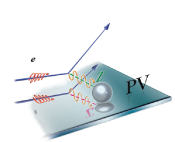

GEM Readout Operation

Hit Distributions of GEM detector planes:LHRS

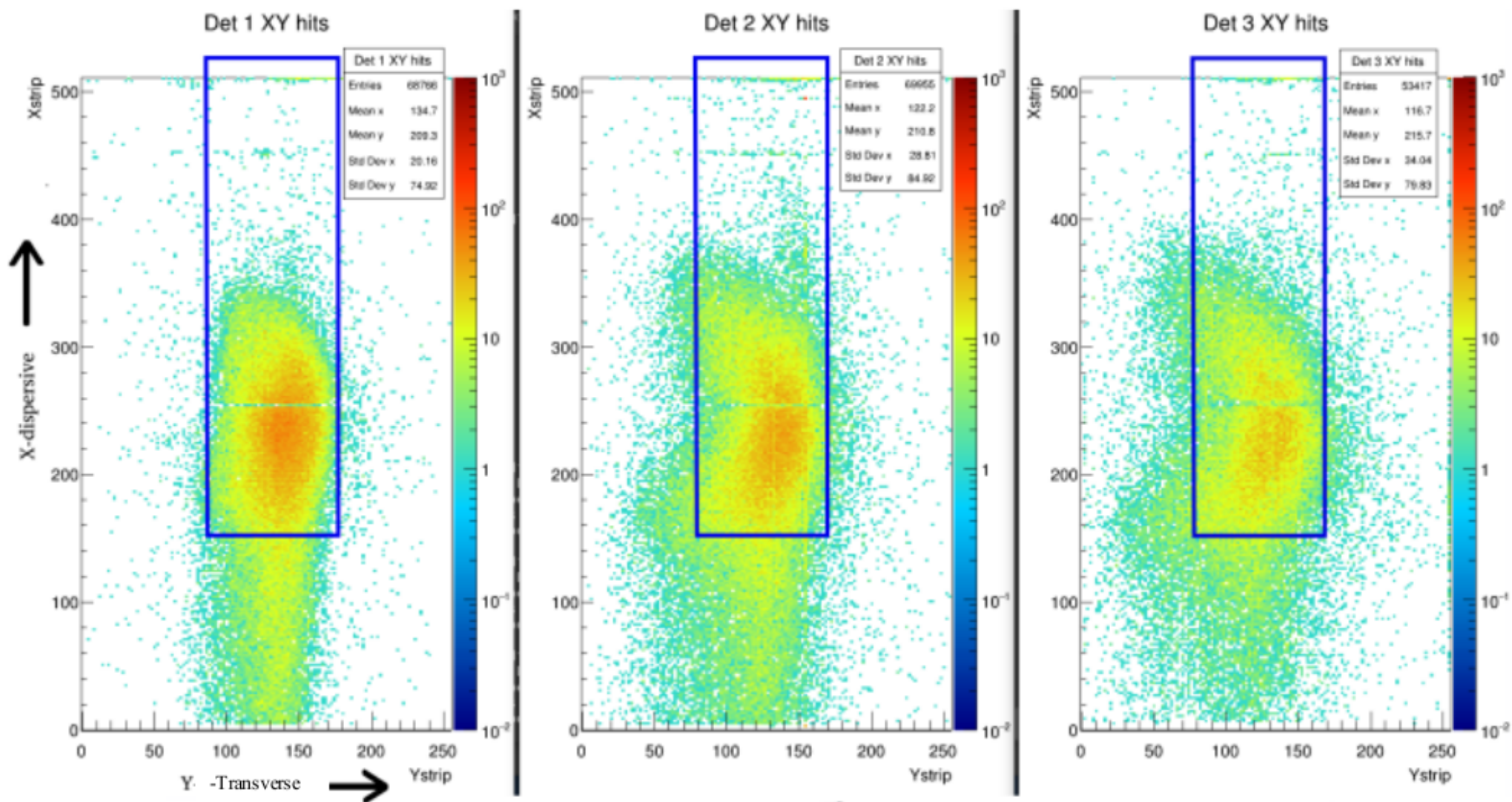

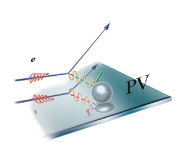

GEM Readout Operation

Hit Distributions of GEM detector planes:LHRS

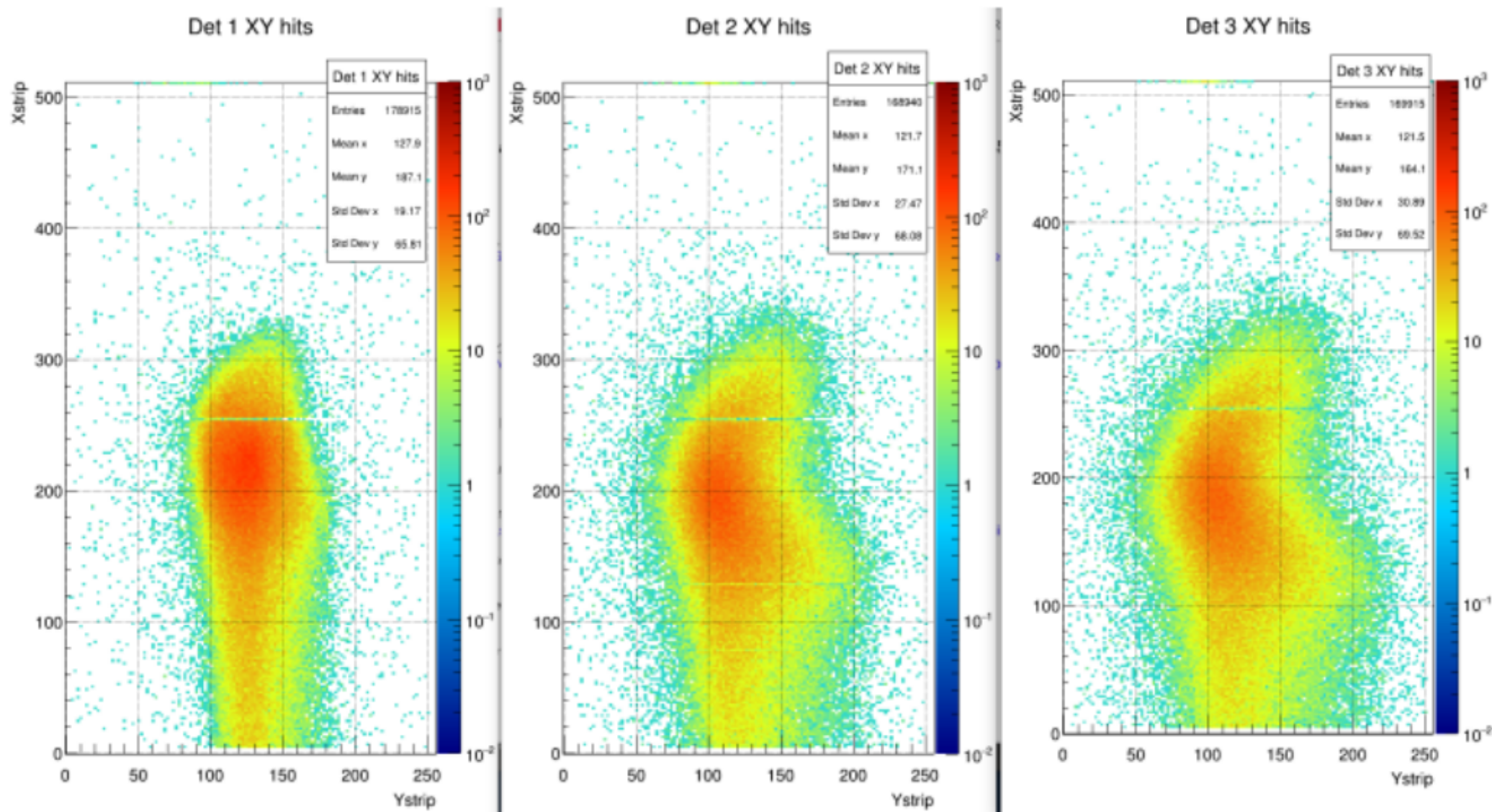

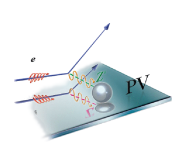

GEM Readout Operation

LHRS: VDC vs GEM Theta-Phi correlation

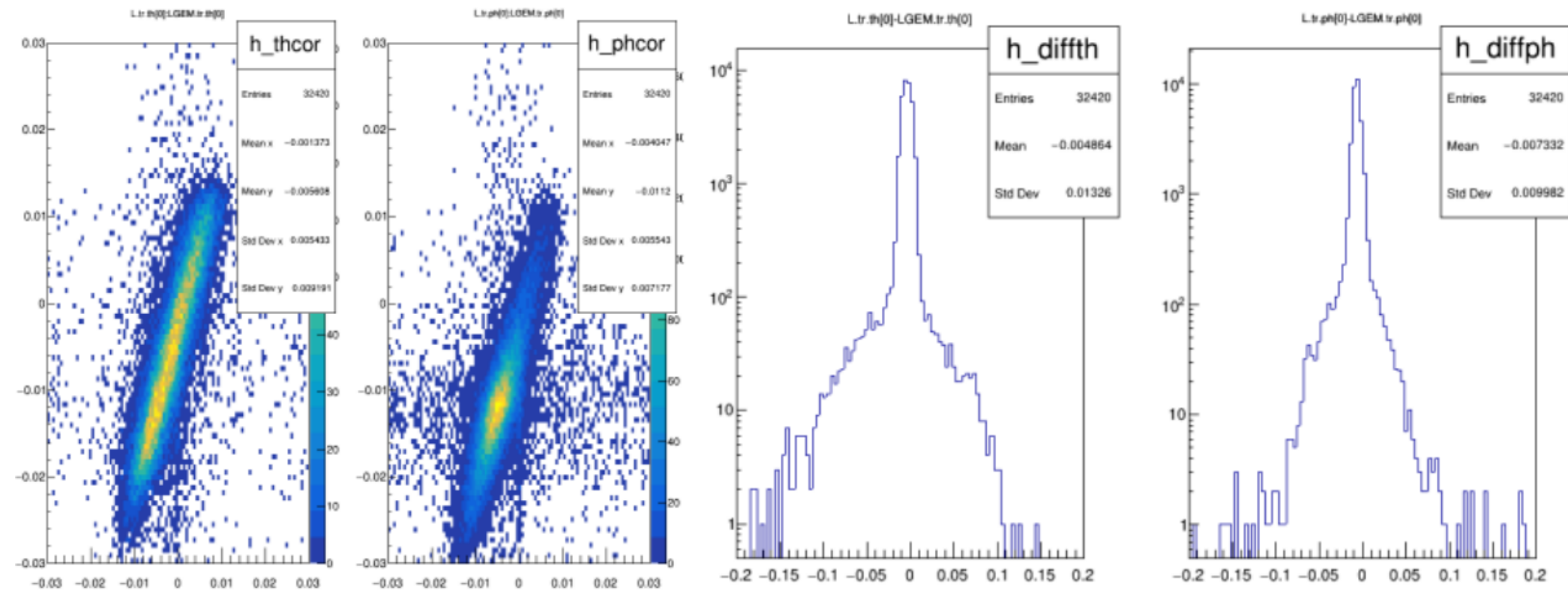

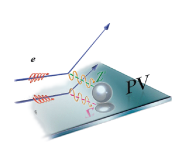

GEM Readout Operation

RHRS: VDC vs GEM Theta-Phi correlation

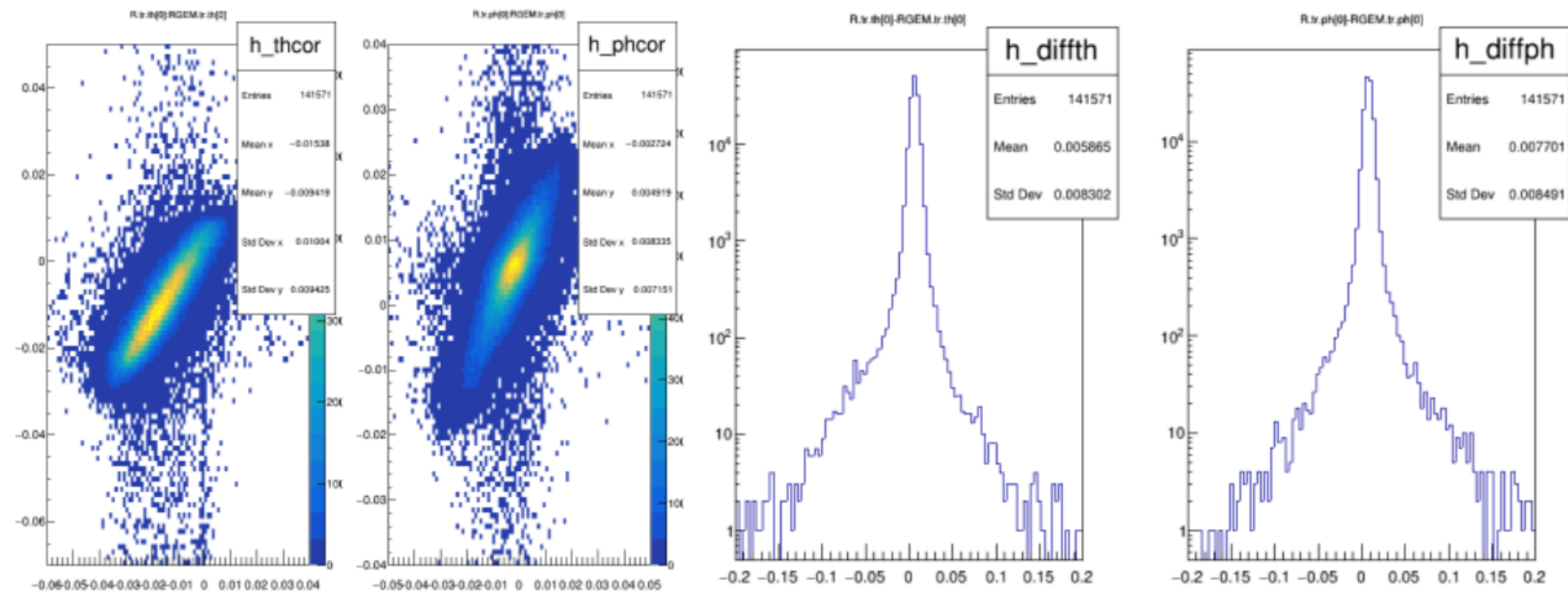

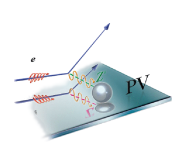

PREX-II/CREX Detector Package

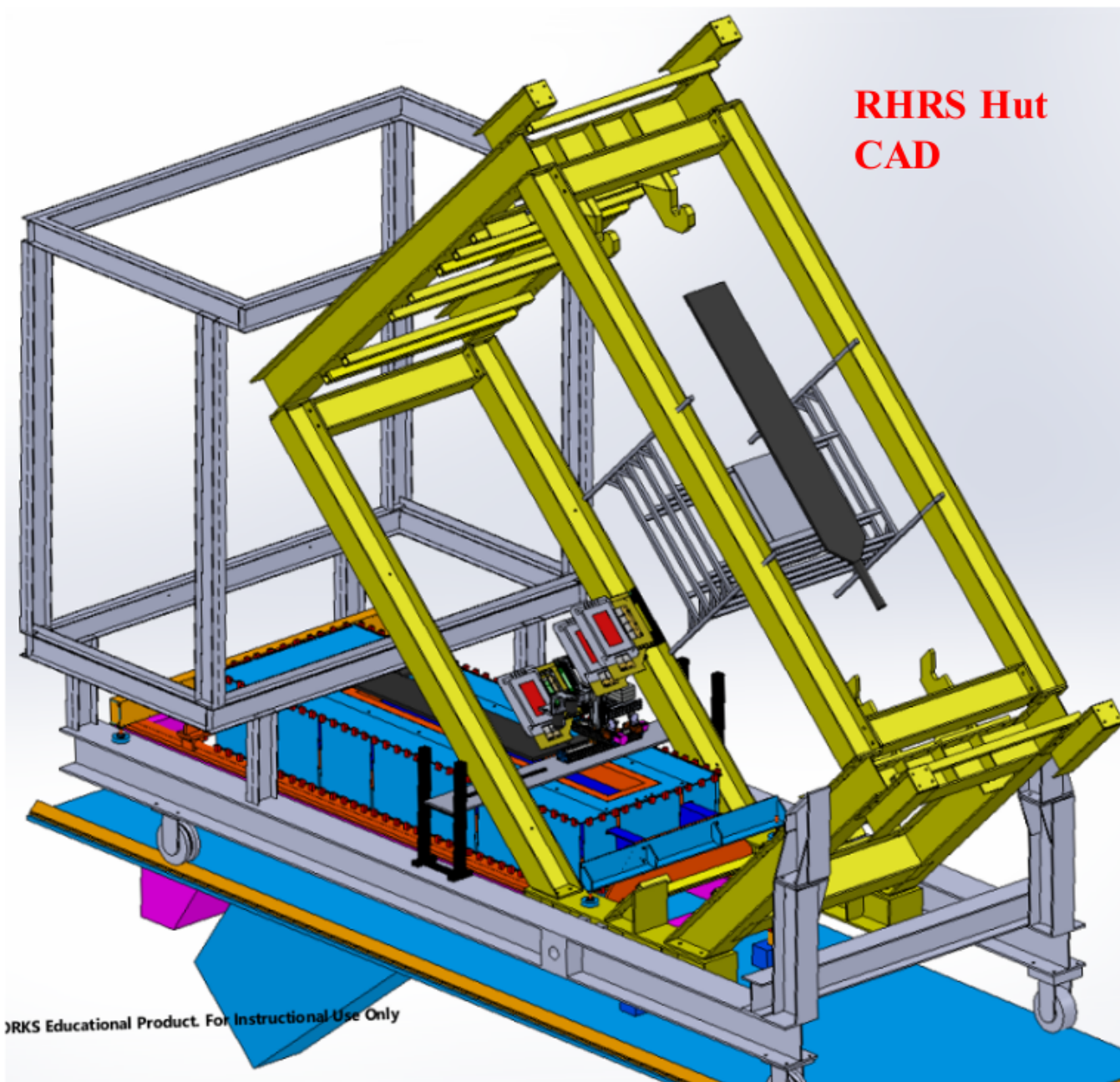

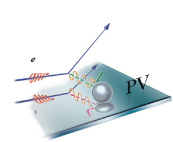

Right HRS Detector Package Installation June 2019

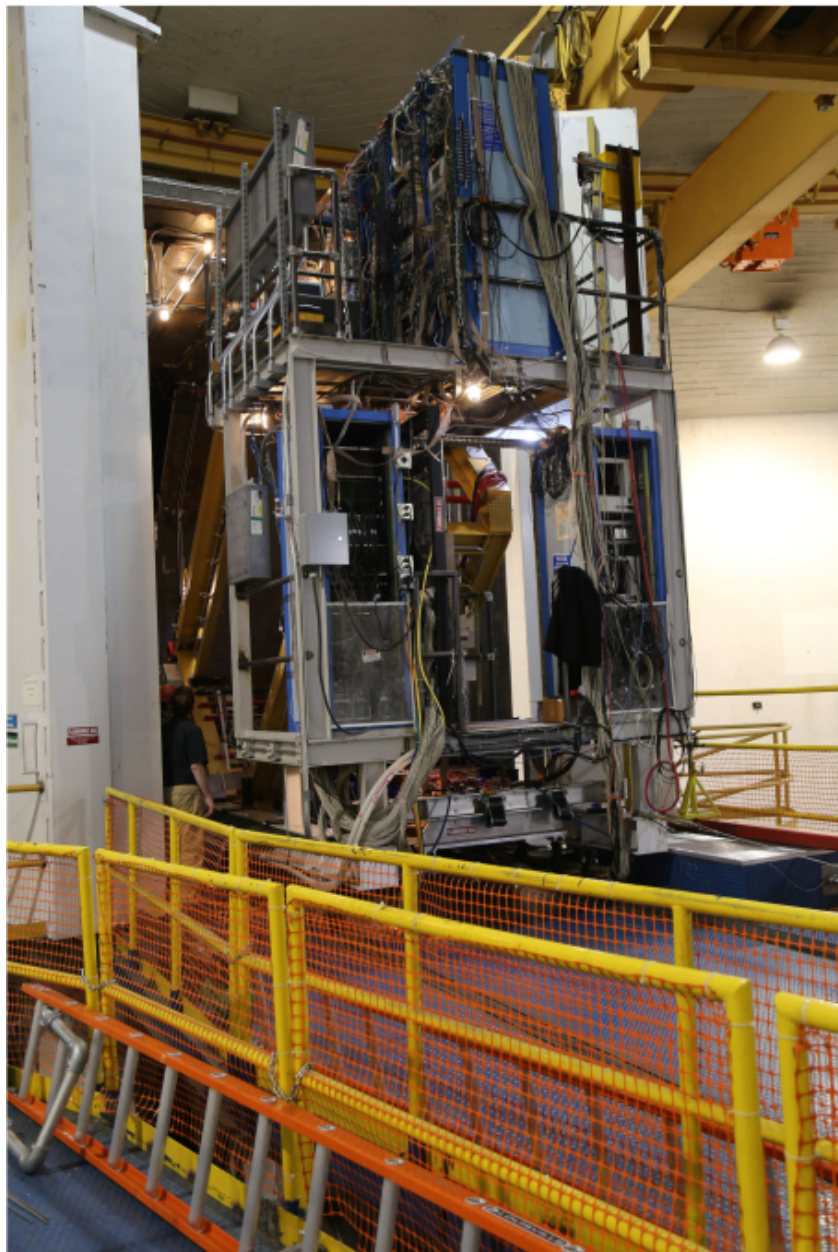

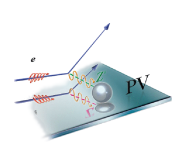

PREX-II/CREX Main Detector Assemblies

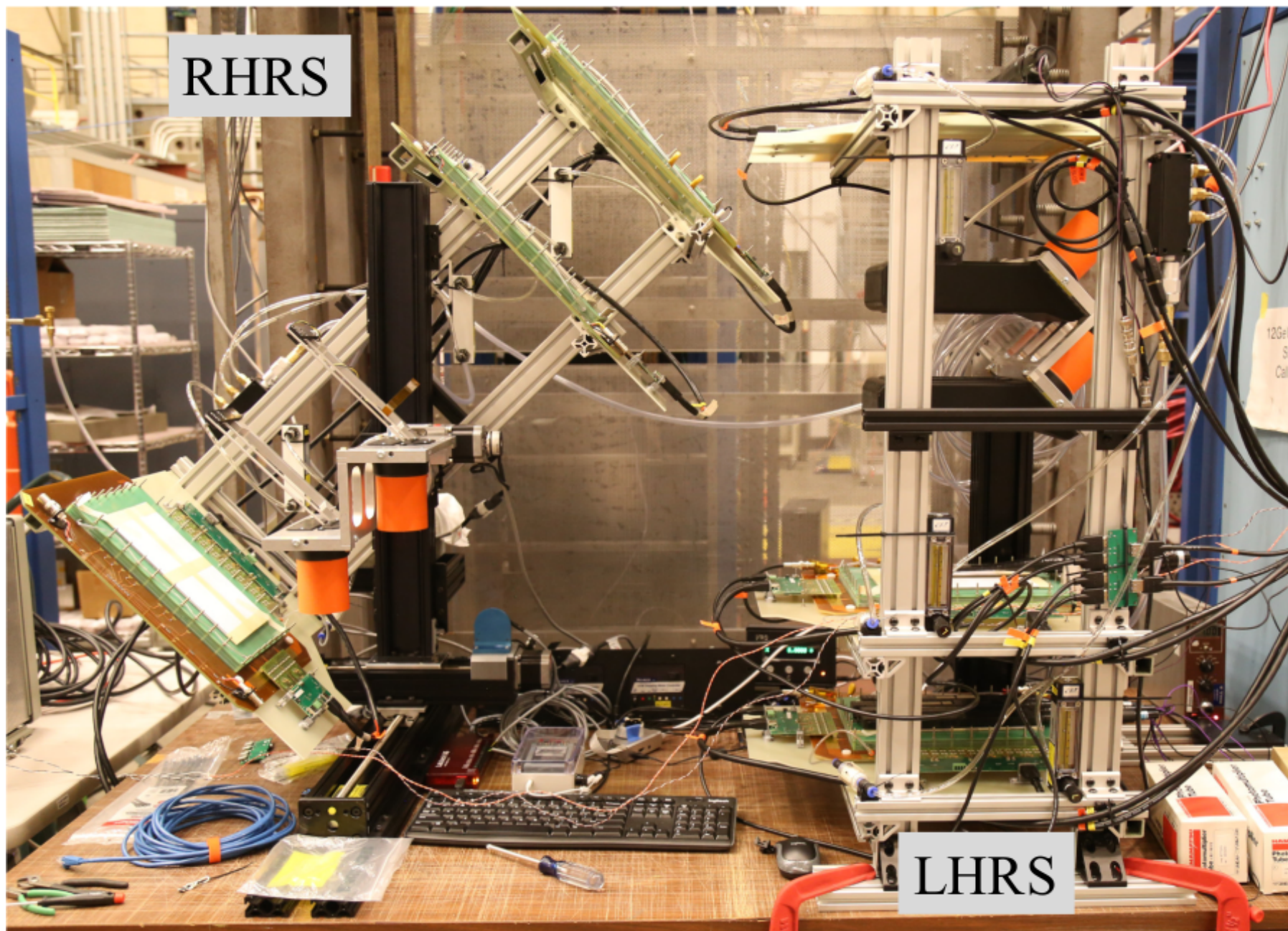

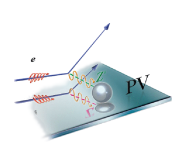

LHRS GEM stand in Cosmic-ray mode

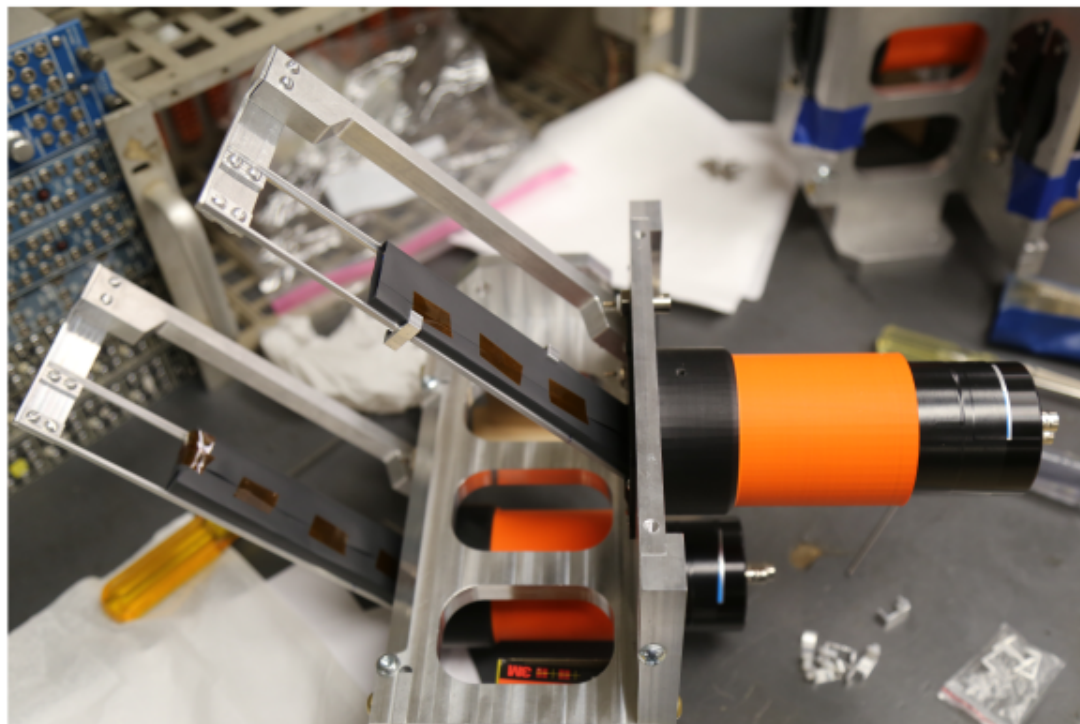
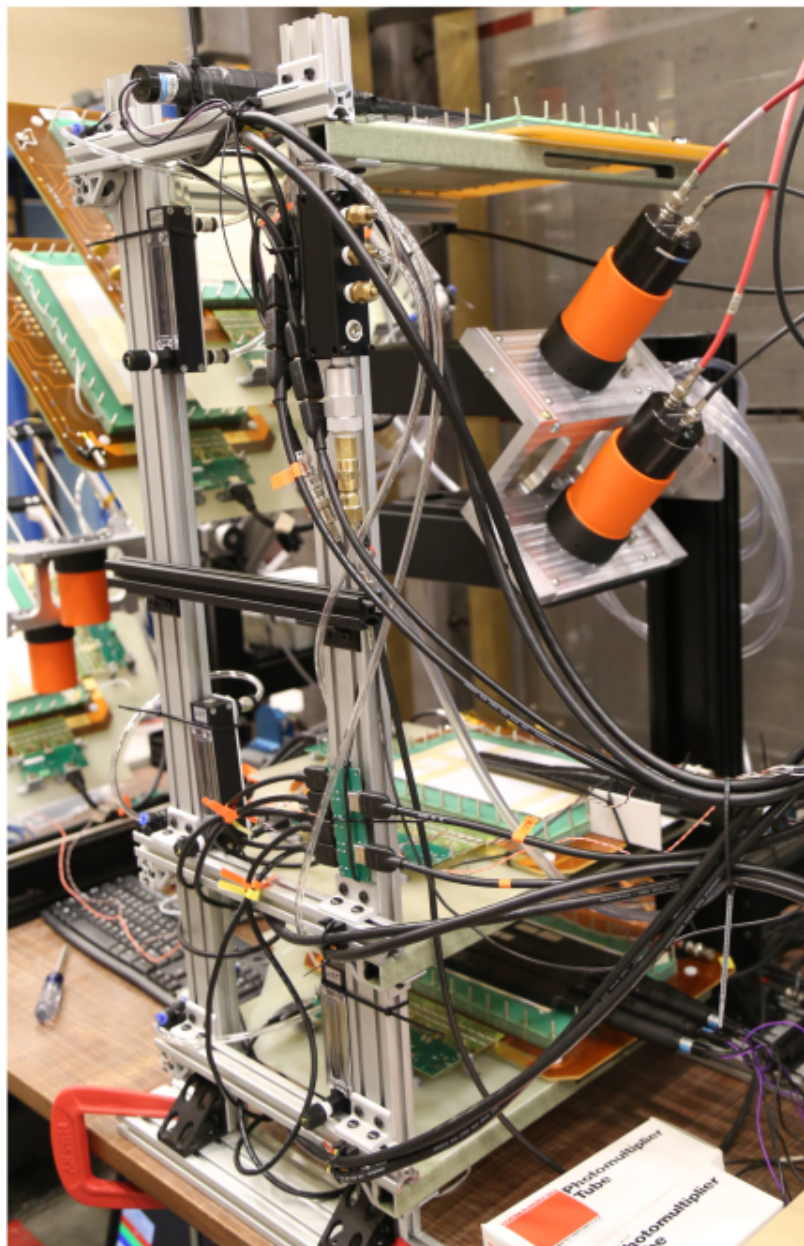

- PREX-II and CREX used 5mm thick quartz in all integrating dets.
- Main and A_T detectors all used Hamamatsu R7723Q pmts

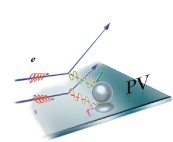

List of past and present undergraduate research assistants within past 7 years

Student	Contribution	Current Status
Kevin Rhine	LG Designs: SAMs and Shwr-max	Grad. 2015; Grad Stud. USU
Brady Lowe	DAQ setup, PMT gains, CREX det.	Grad. 2015; MS 2019
Blake French	CODA event-viewer, Cosmic-stand	Grad. 2015; job at Micron
Dayah Chrisman	PMT gain analysis macro	Grad. 2015; Ph.D. MSU 2021
Will Gorman	Cosmic-ray data analysis	Grad. 2014; Grad.Stud. U of Roch.
Max Sturgeon	Bending Al. Light Guides for SAMs	Grad. 2017
Chase Juneau	CAD; reflectivity meas.	Grad. 2017; job at INL
Daniel Sluder	Shower-max chassis CAD, ...	Grad. 2016; MS 2018; job at INL
Joey McCullough	GEM readout backplanes; SLAC tests	Grad. 2017; Grad. Stud. ISU
C. Royal Cole	SLAC testbeam stand	Grad. Dec 2018; Medical School
Eighdi Aung	GEM CAD	Grad. 2019; Grad. Stud. Va Tech
Rajul Chauhan	PREX-II/CREX det. motion control	Grad. 2019
Justin Gahley	SLAC testbeam stand motion control	Grad. 2020; Grad. Stud. ISU
Alec Lepisto	3D printing parts; SLAC analysis	Grad. 2021; Grad. Stud. Philos.
Brandon Pearson	Designing and 3D printing parts	Grad. 2021; job at INL
Ryan Bluemel	Shower-max design update	Grad. 2021
Edwin Sosa	Detector design CAD	Expected Grad. 2023
Coltyn Fisher	Quartz Irradiation study	Expected Grad. 2023
Kouasi Kouakou	Quartz Irradiation study	Expected Grad. 2023

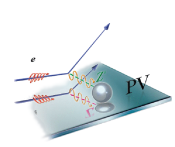

Students at Work at Jefferson Lab and SLAC

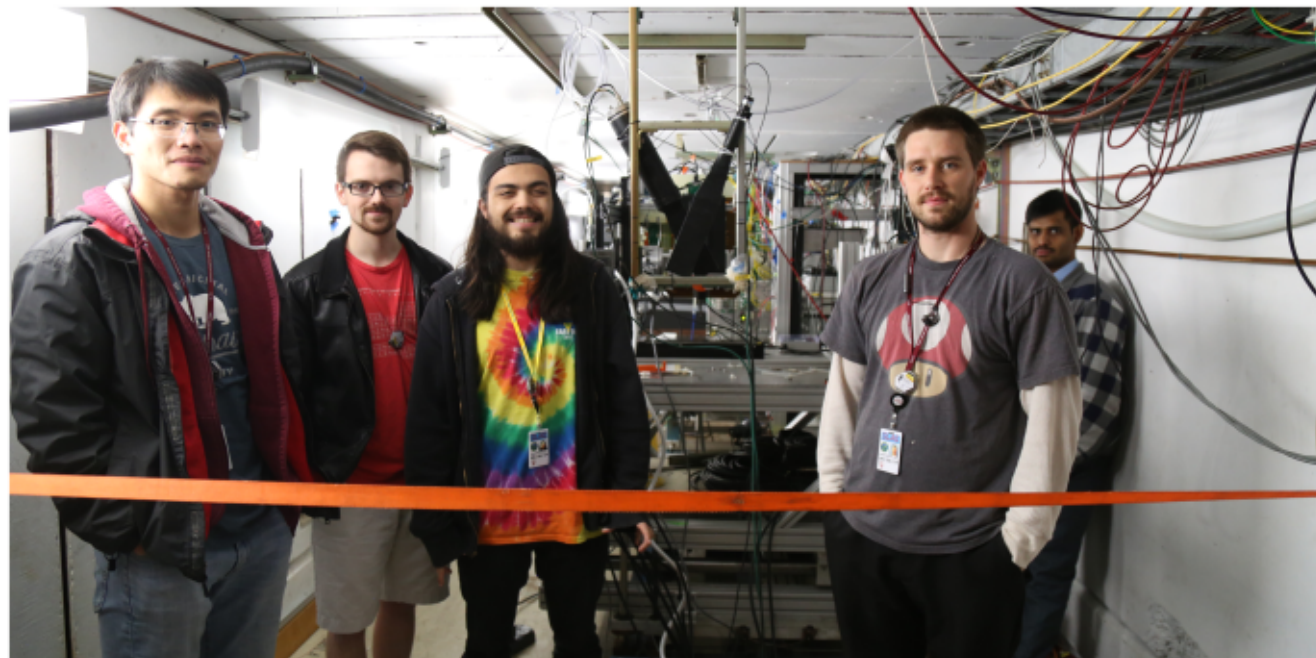
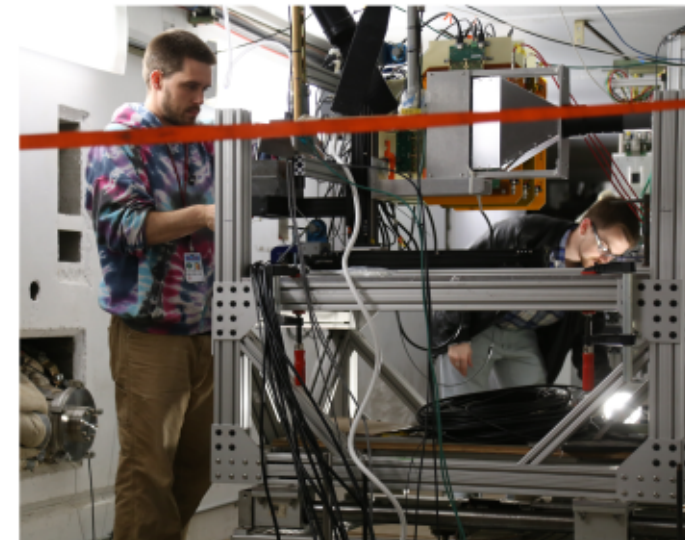

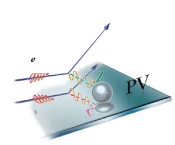

Summary and Future Plans

- PVES is a precision tool for measuring weak-charge distributions with implications for nuclear structure and BSM discovery

PREX/CREX:

- Both experiments ran successfully. CREX was interrupted by pandemic, but finished in Sep 2020 still running
- ISU's many contributions were all a wild success: Two main tandem quartz detectors with GEM trackers and remote motion system, two sets of auxiliary quartz detectors, and 3 generations of SAM systems

MOLLER Shower-max and SAMs

- Much progress over past several years on Shower-max— robust baseline design prototyped and tested
- First shower-max testbeam run at SLAC in Dec 2018; second prototype underway now; plan to take to Fermi Lab for test beam
- ISU Cosmic-ray GEM stand will be re-commissioned this fall to start testing shower-max design changes

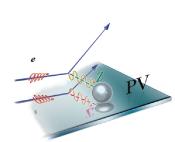

Extra Slides

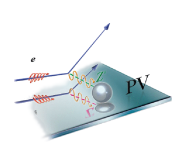

Motivations for Downstream Lumi's or SAM's

- Need them for their high sensitivity to helicity-correlated beam parameters
 - Detect charged particle flux at extreme forward angles
 - Very high rates and thus narrow pulse-pair widths – powerful diagnostic tool



- Provides measure of overall electronic noise floor in the hall
- In theory, should have very low/no PV asymmetry and can serve as null asymmetry monitor
- Symmetric 8 piece design helps disentangle beam position and angle HCBP's while 8 SAM sum is insensitive
- Could provide important tests of regression procedures

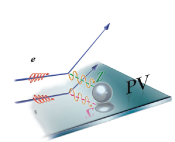

Old Hall A Luminosity Monitor

Luminosity Monitor

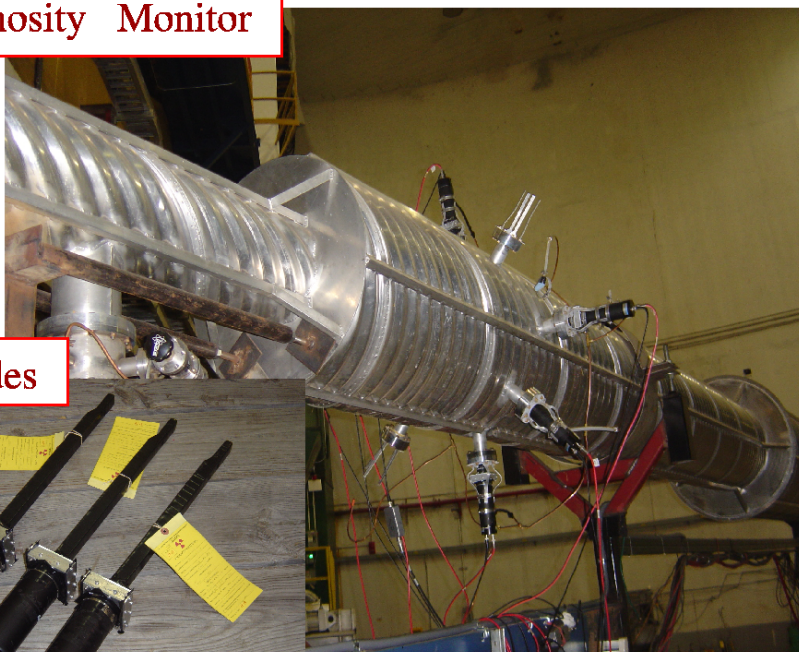

Upgrades

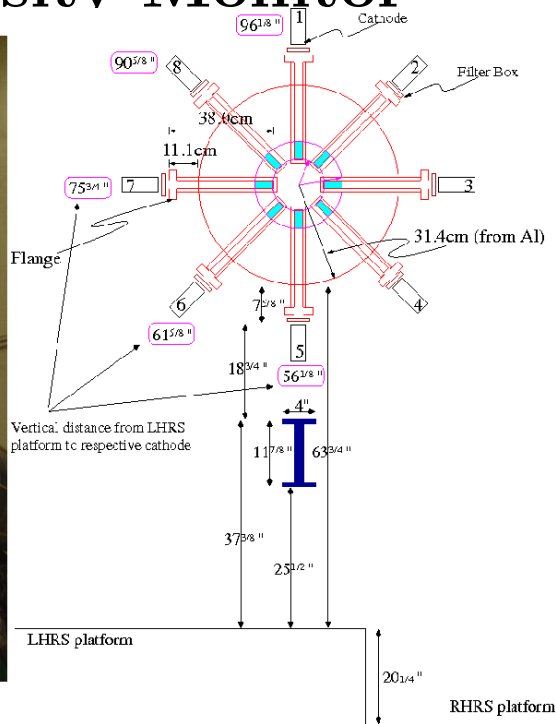

- Conceptual Design 2002–Riad Suleiman; refurbished in 2008
- 8 quartz Cherenkov detectors with air-core light guides placed symmetrically around beam line 7m downstream of pivot
- Used $6.0 \times 2.0 \times 1.0 \text{ cm}^3$ quartz placed 4.5 cm from beam center \Rightarrow 0.3 - 0.8 deg polar angle acceptance

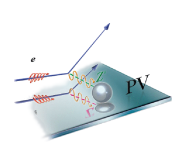

Luminosity Monitor Re-design (SAMs)

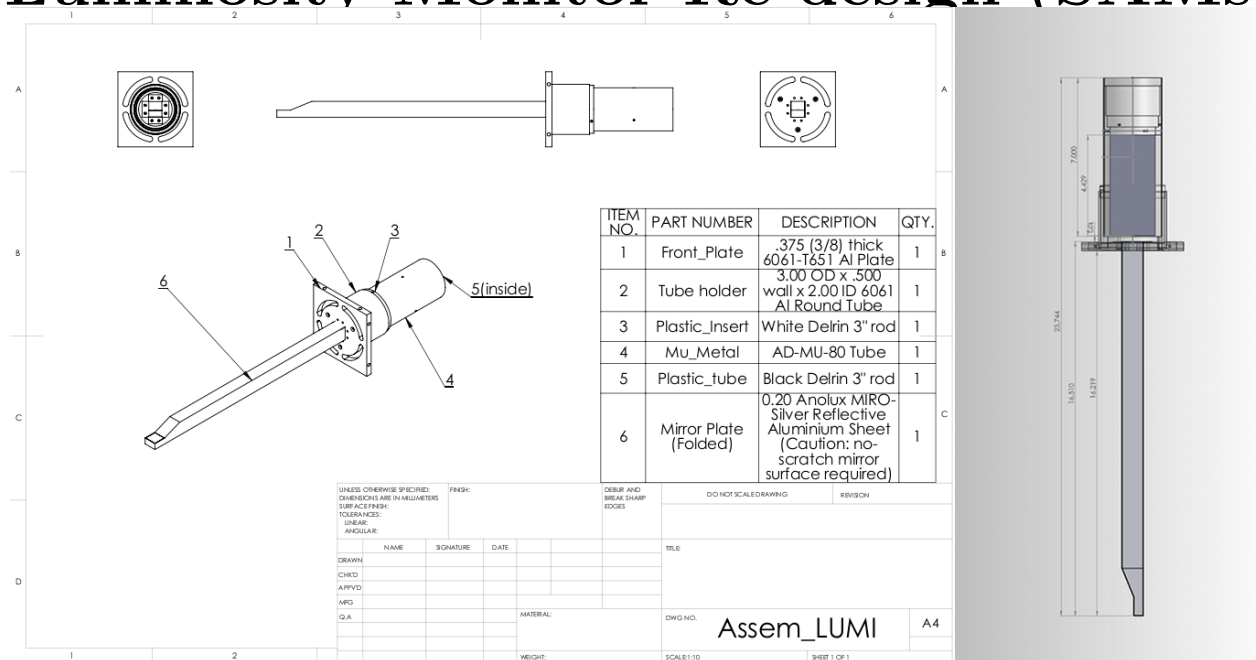

- Incorporate Qweak's downstream Lumi experience:
 - Use pre-radiator and "unity gain" PMT
 - Use radially smaller, but thicker quartz
 - May achieve desired linearity at anticipated photocathode currents, but running unity gain mode guarantees it
 - Use TRIUMF preAmps at SAM for signal cond. and gain
- *Work within constraints of existing beampipe insertion tubes*

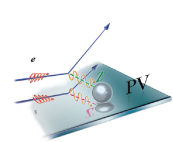

Final SAM Design and 2016 Testbeam

MAMI testbeam run May 24 -27, 2016

855 MeV e⁻ beam

Hall A SAM

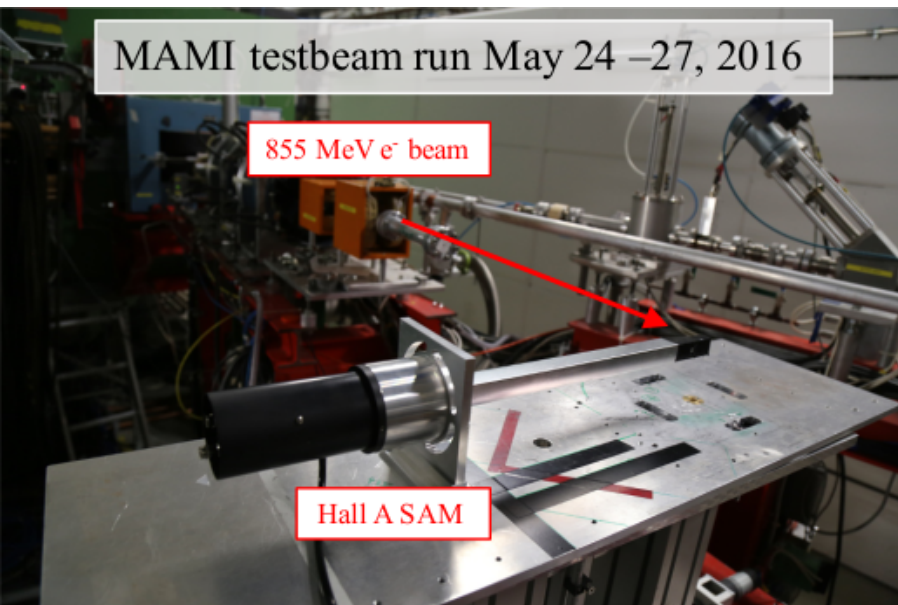

- Final (v3) SAM detector PE yield studies:
 - MiroSilver27 and UVS light-guides
 - With and without 1cm tungsten pre-radiator



Small Ange Monitors:
Detect ~0.5° target scattering

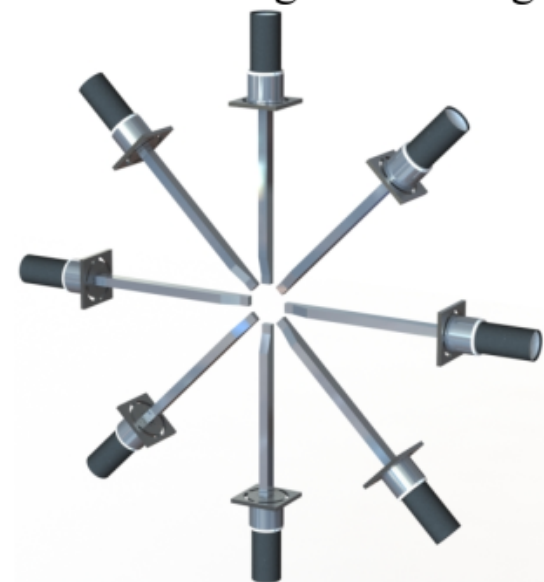

Assembled & Installed in Hall A Fall 2015

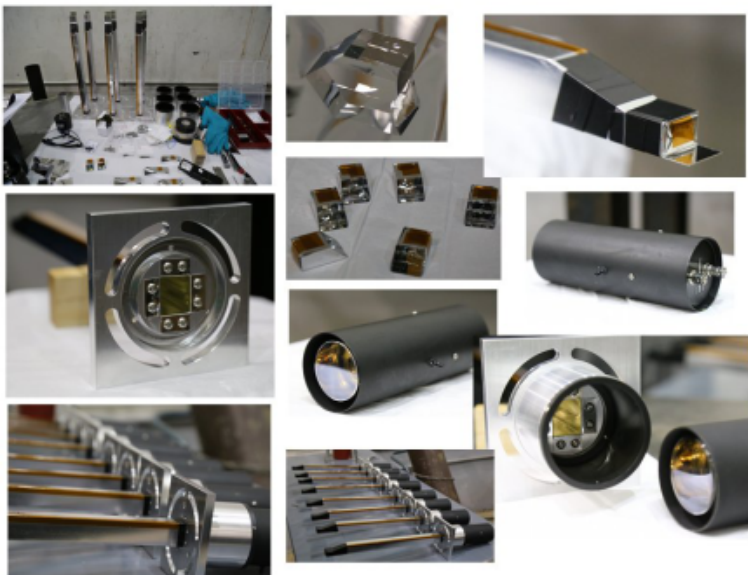

v3 SAM detector

- Quartz: 33 x 20 x 13 mm³
- Miro27 LG: 36 x 2.6 x 2.1 cm³
- Optimized 1-bounce funnel mirror
- Unity or high-gain R375 2" PMTs
- Use of pre-radiator not decided
- Dry-air inlet and outlet ports
- Custom flange adapter for easy de-install/re-install (radcon permitting)

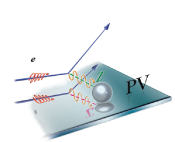

Optical Monte Carlo (qsim) Benchmarking: SAMs

Photo-Electron Distribution - simulated vs real data

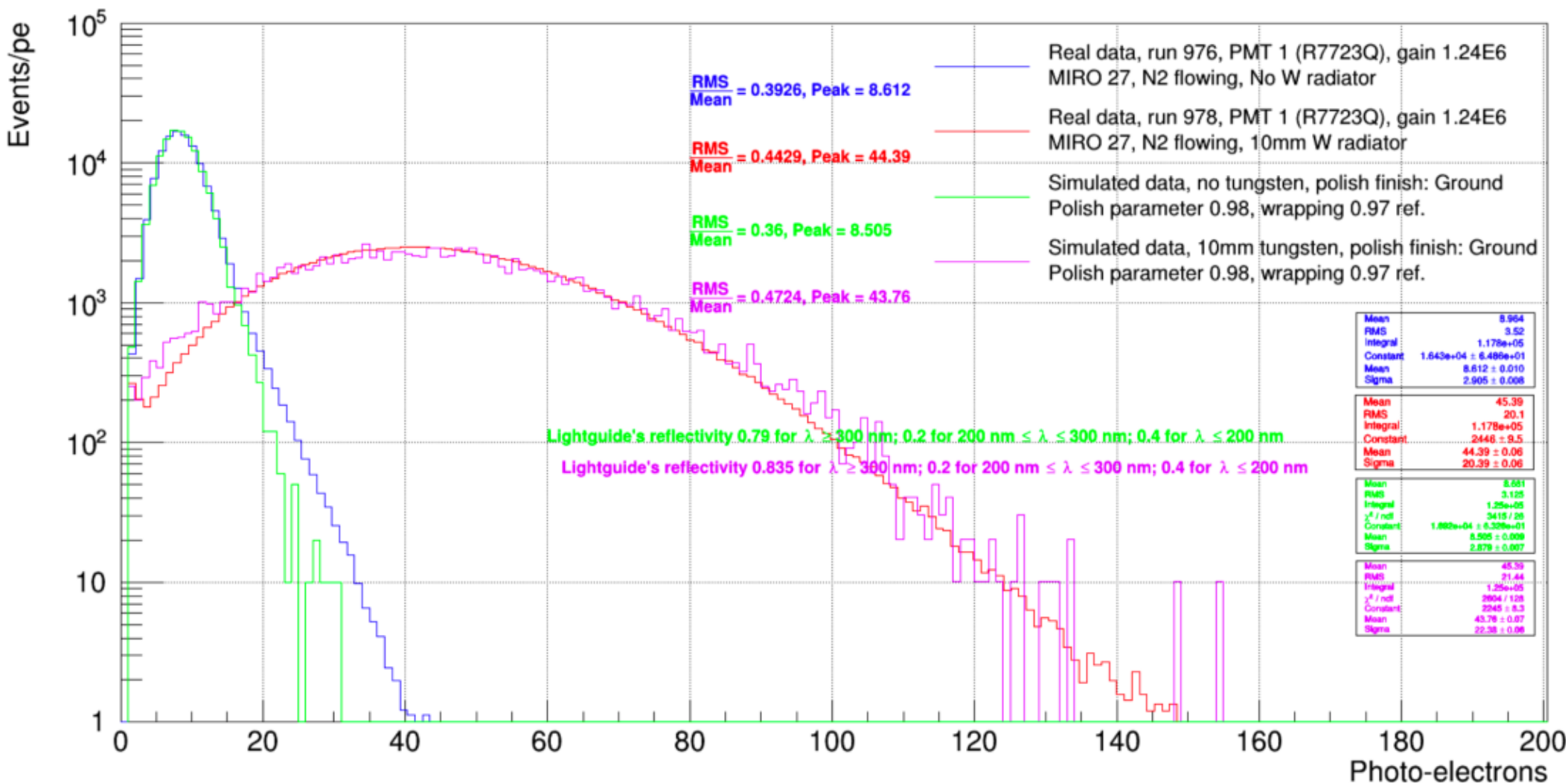

Sep 25 01:24:10 2017

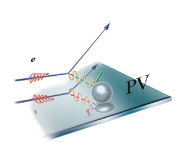

SAM light guide reflectivity: explored many options

Reflectivity (~90 degree)

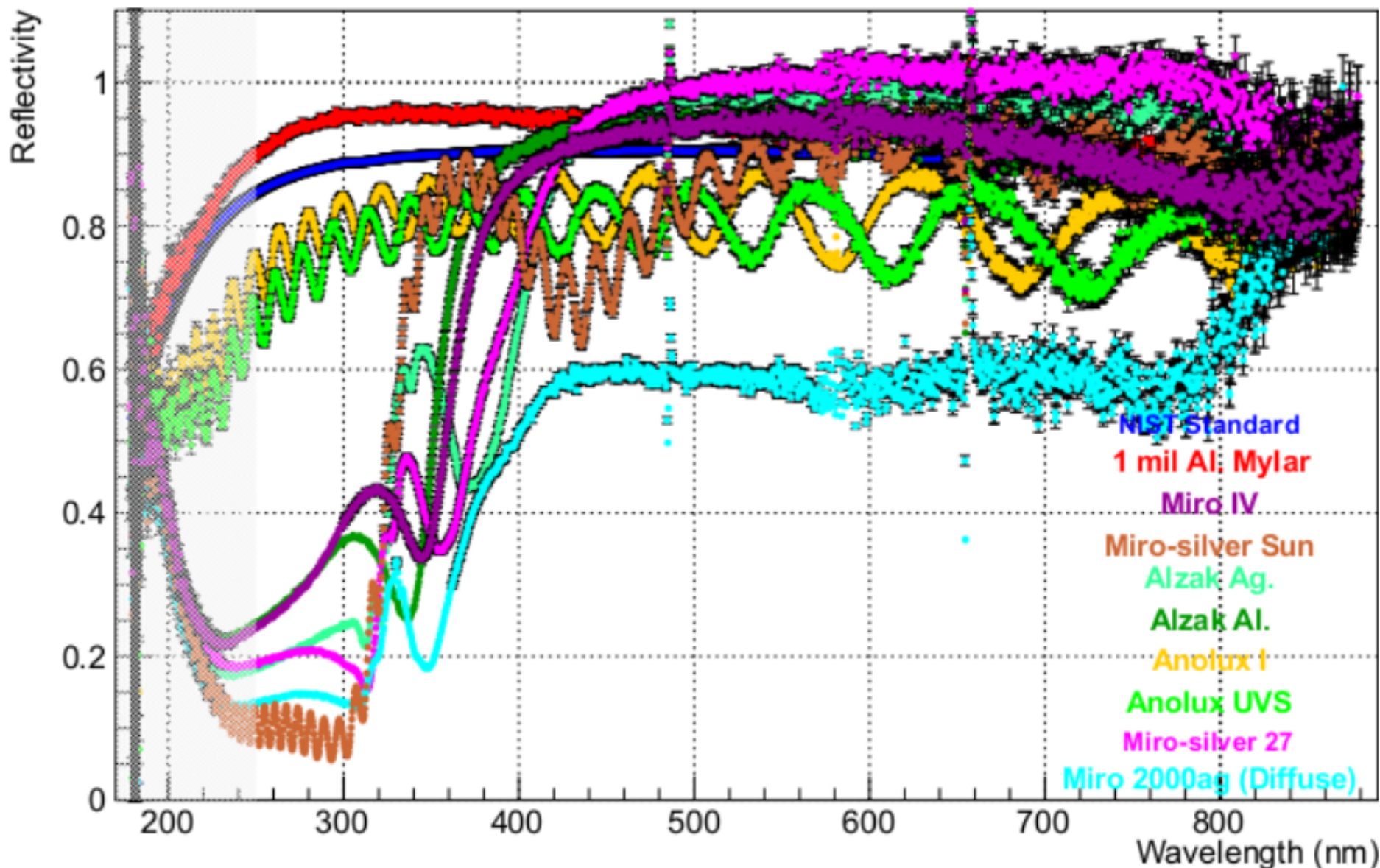

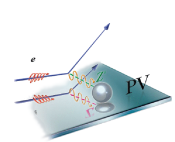

SAMs currently installed (v3: since Dec 2015)

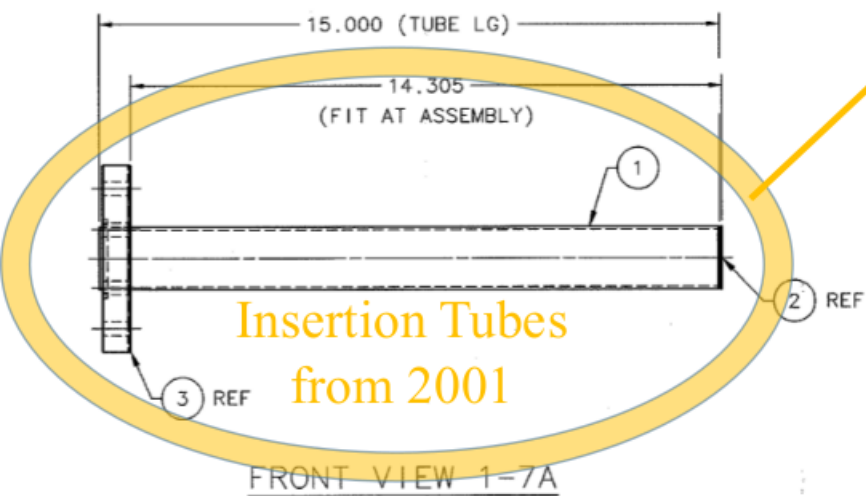
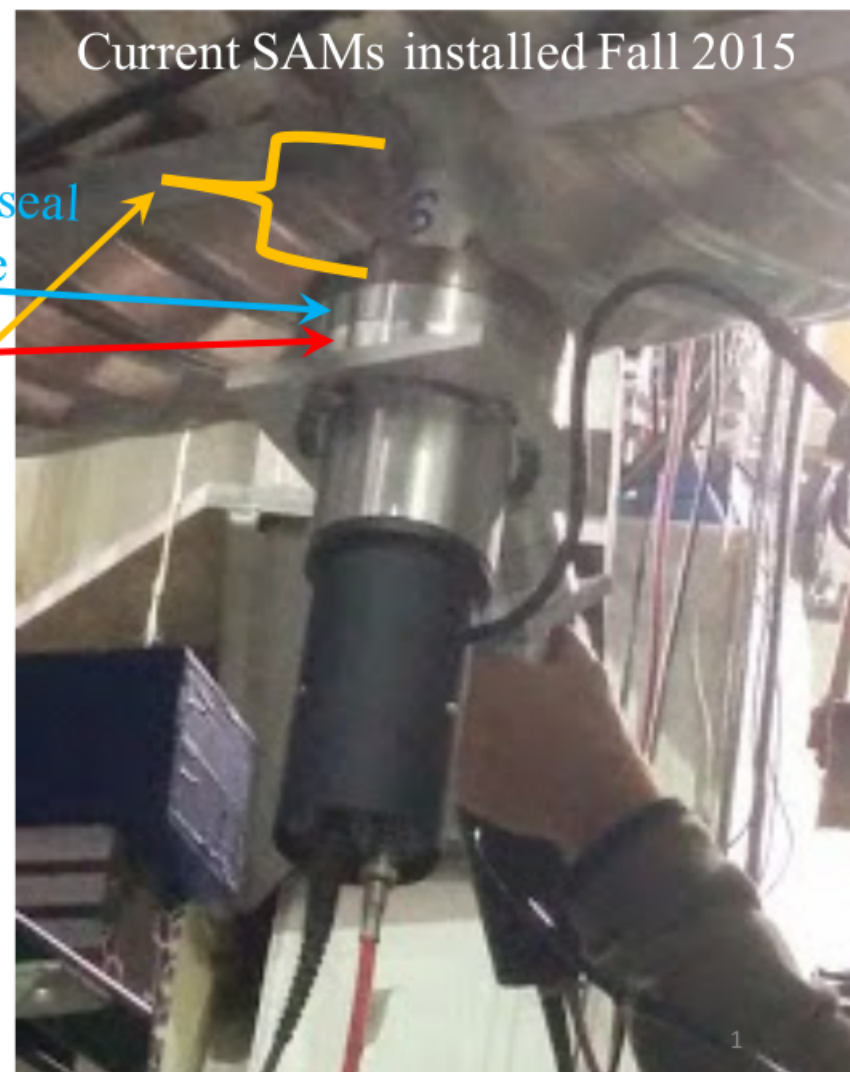
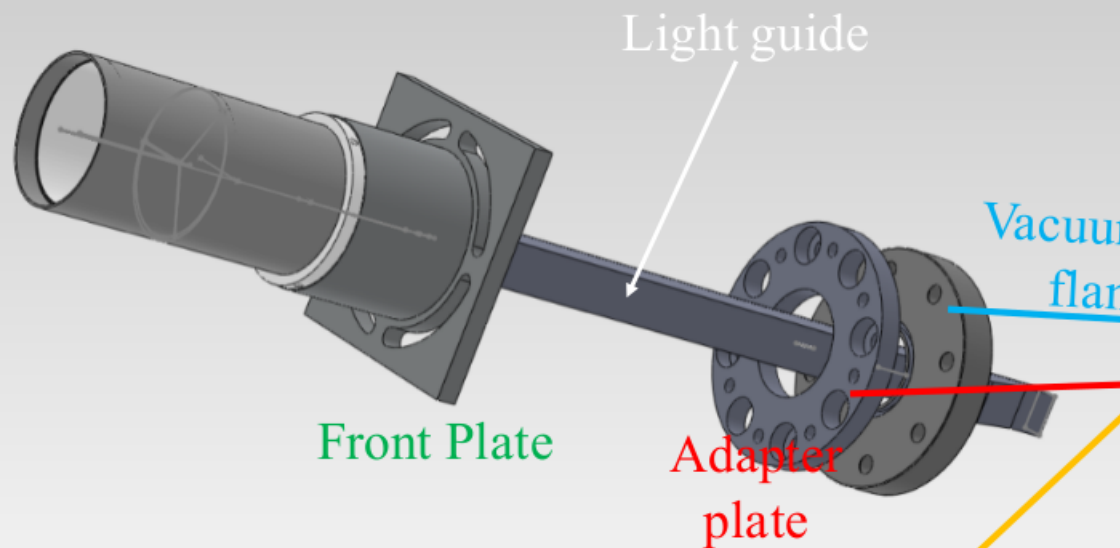

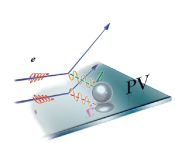

New SAM quartz: thinner and shorter

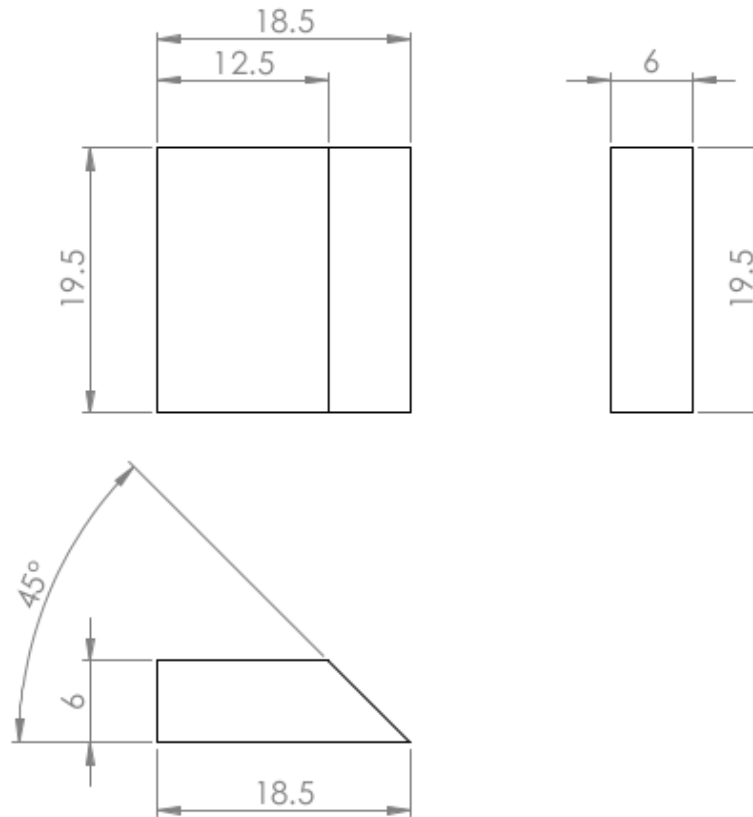

UNLESS OTHERWISE SPECIFIED: DIMENSIONS ARE IN MILLIMETERS SURFACE FINISH: TOLERANCES: LINEAR: ANGULAR:				FINISH:		DEBURR AND BREAK SHARP EDGES		DO NOT SCALE DRAWING		REVISION			
								TITLE: quartz_SAM					
DRAWN				NAME		SIGNATURE						DATE	
CHKD													
APPVD													
MFG													
Q.A								MATERIAL:		DWG NO.			
										A4			
								WEIGHT:		SCALE:2:1			
										SHEET 1 OF 1			

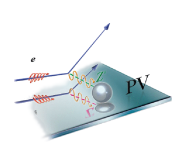

New SAM LG: 3.5 cm shorter, redesigned

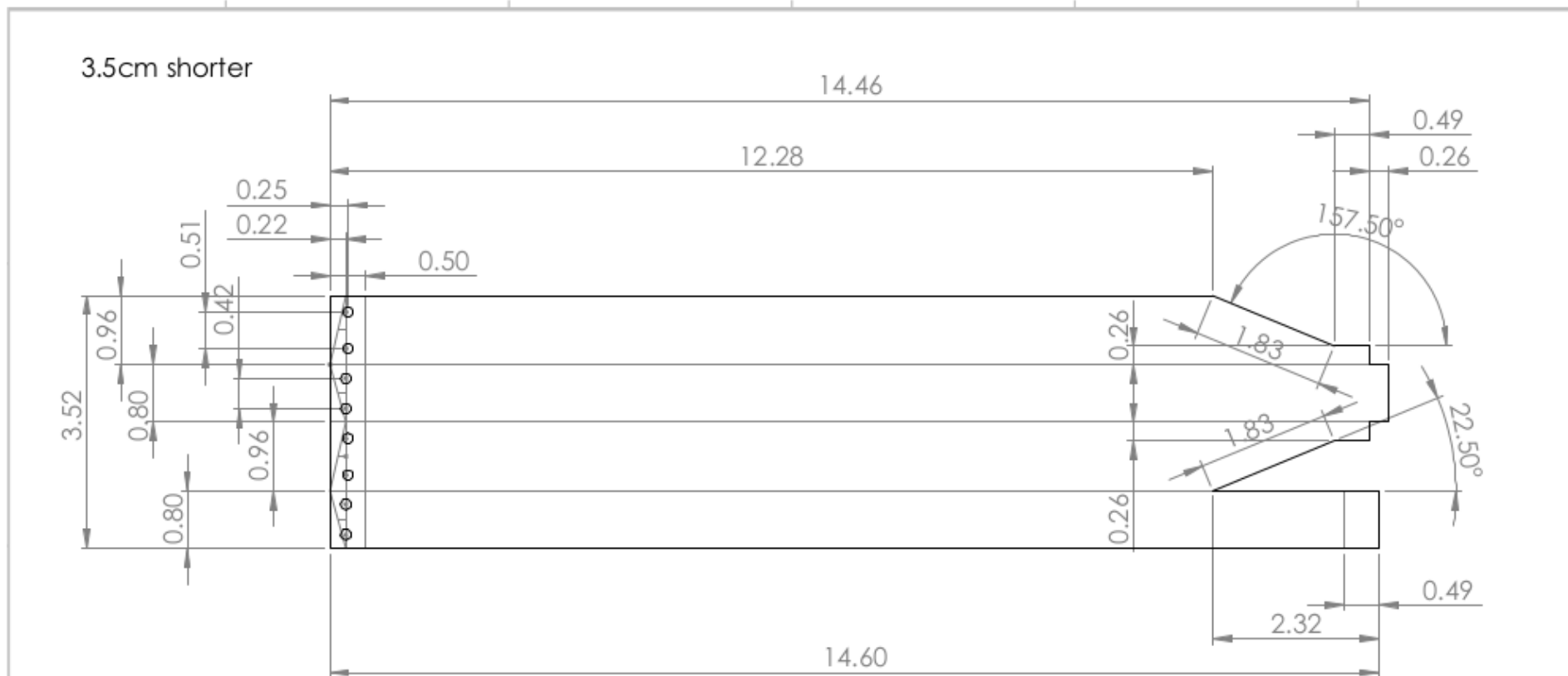

UNLESS OTHERWISE SPECIFIED: DIMENSIONS ARE IN INCHES		FINISH:		DEBURR AND BREAK SHARP EDGES		DO NOT SCALE DRAWING		REVISION	
DRAWN		SIGNATURE		DATE		TITLE: SAMPLATE01			
CHK'D						MATERIAL:		DWG NO.	
APP' D								A4	
MFG						WEIGHT:		SCALE: 1:5	
Q.A						SHEET 1 OF 1			

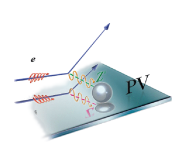

New Vacuum Tubes—shorter; spherical endcap

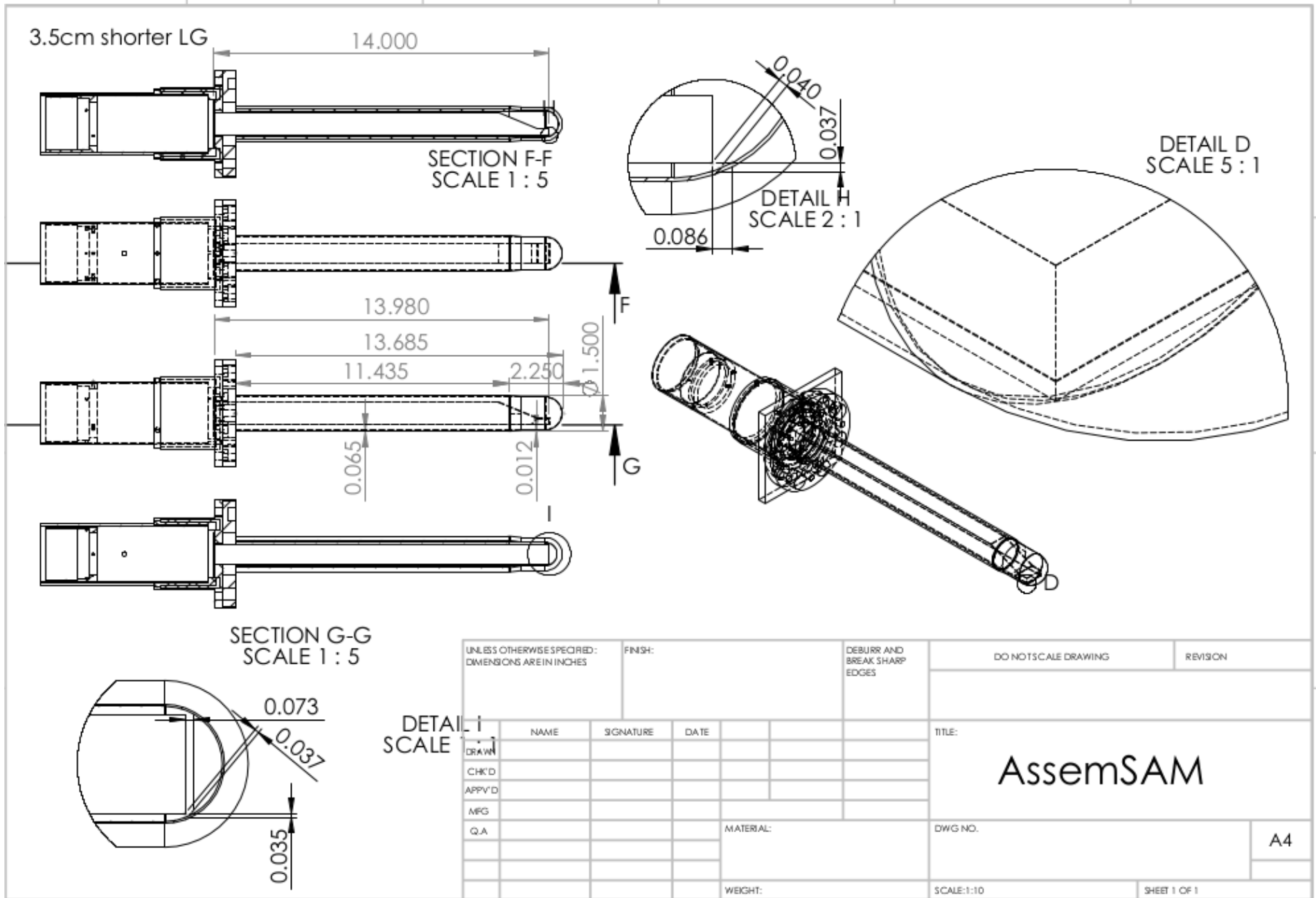

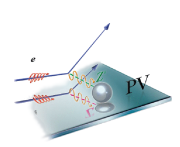

New Vacuum Tubes—weld details

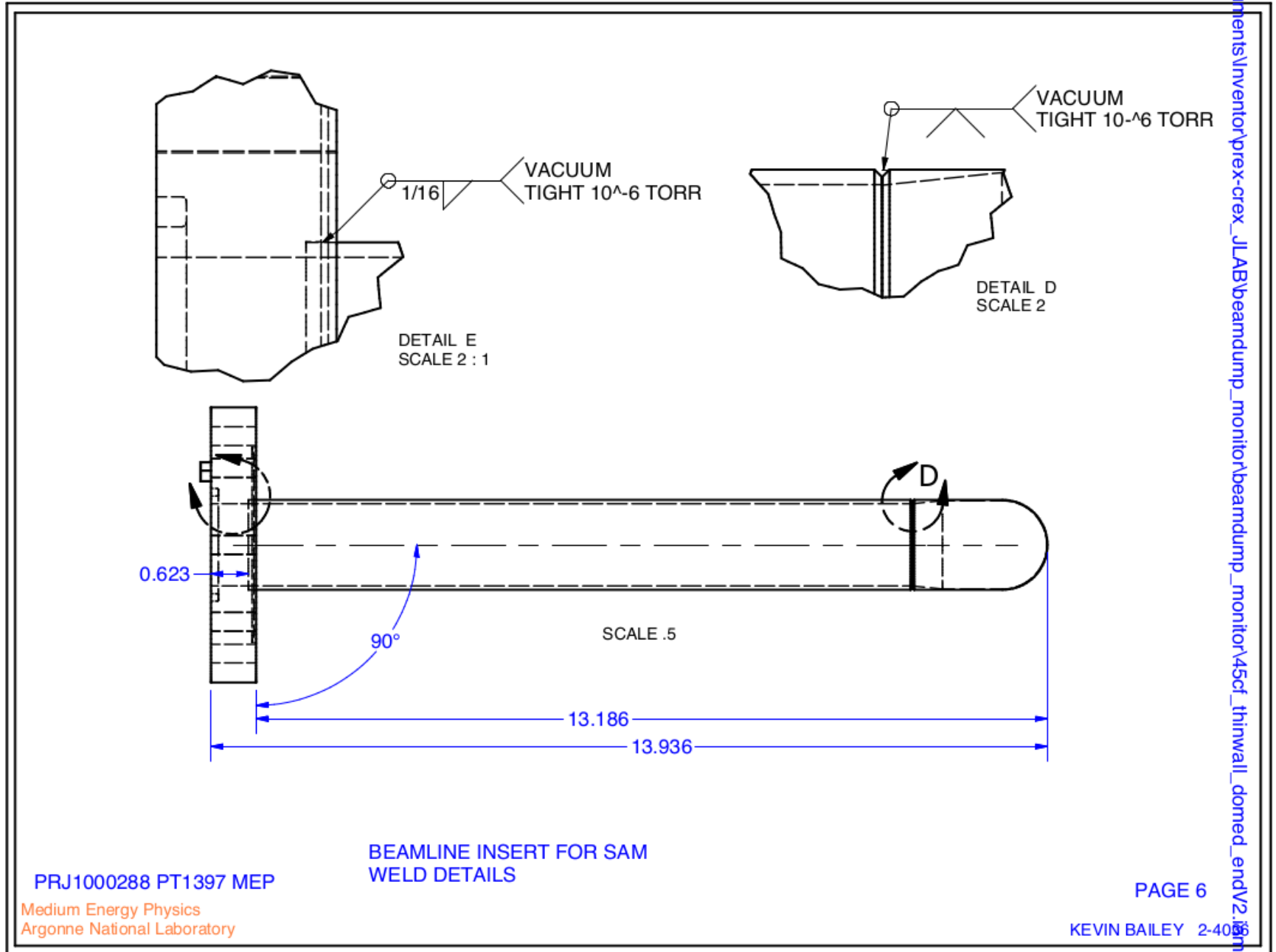

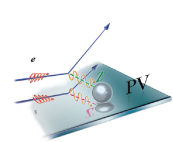

New SAM LG: Shorter by 3.5 cm and optimized funnel angle

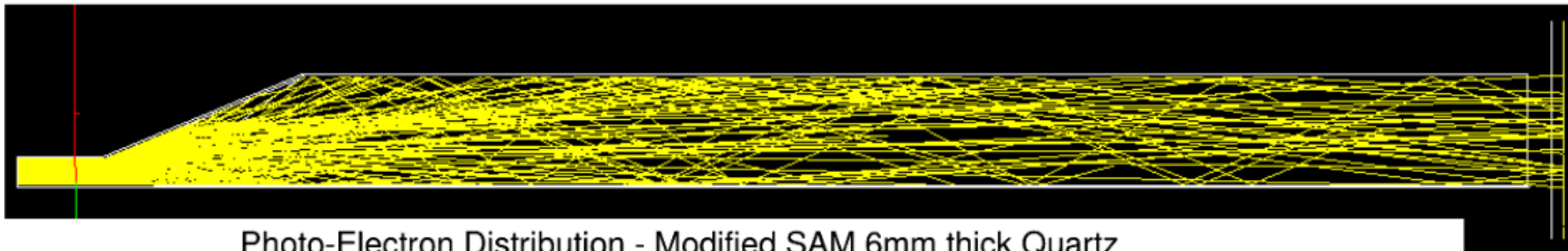
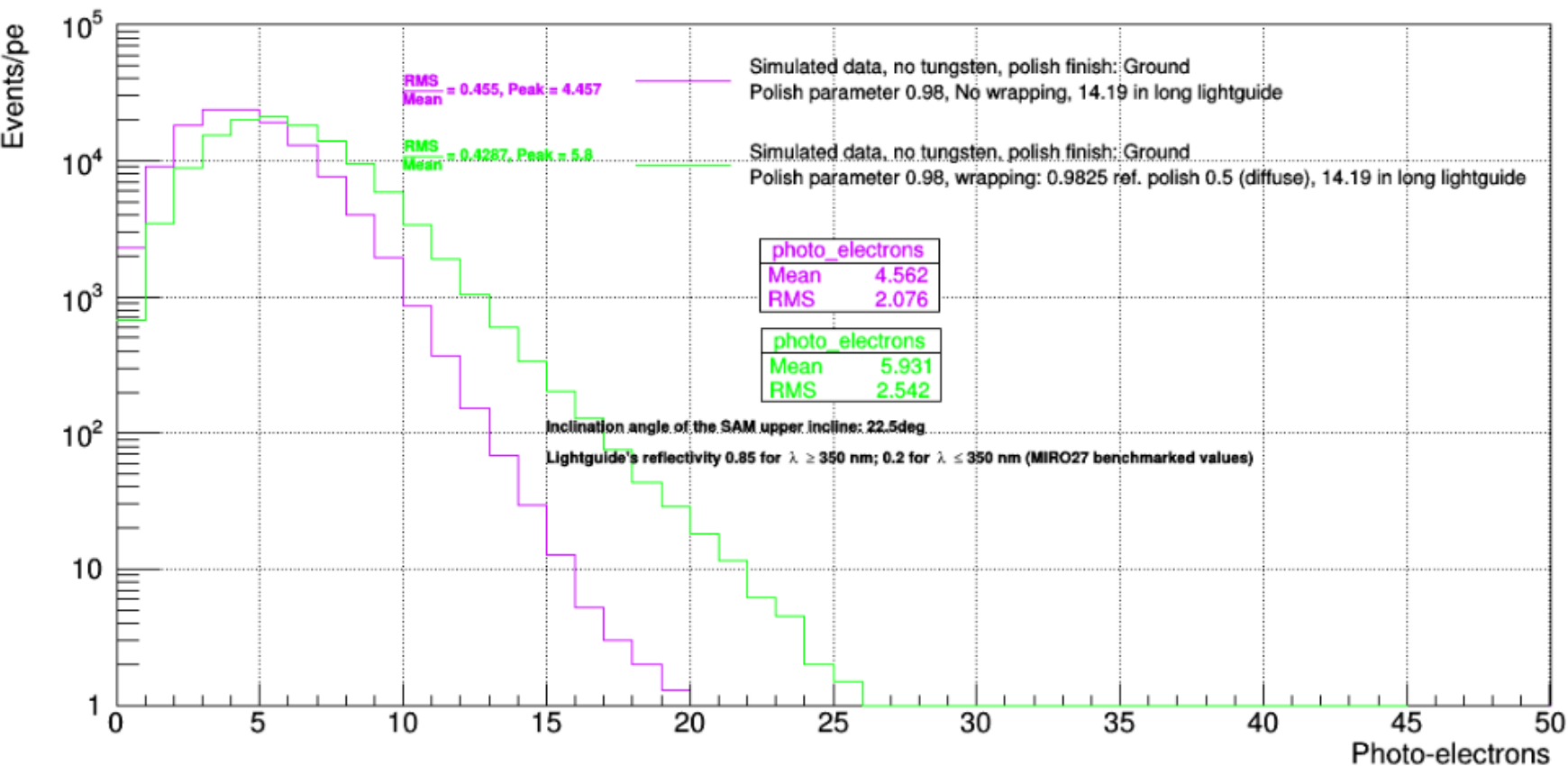
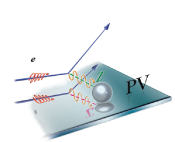

Photo-Electron Distribution - Modified SAM 6mm thick Quartz



About 6 PEs per electron with 43% resolution



Some CAD views of new SAM design

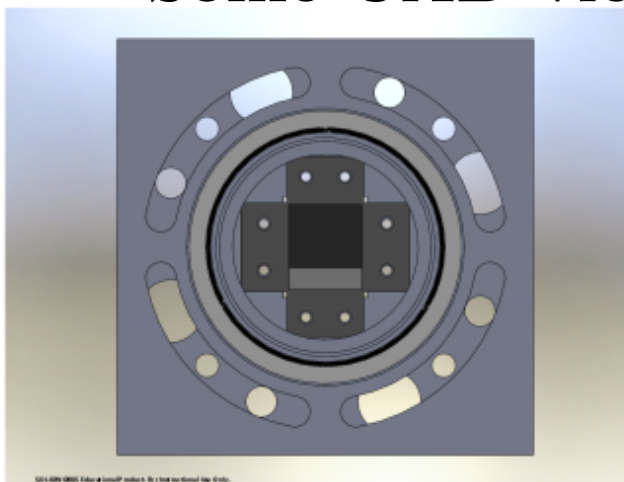

Radial View (looking down the LG towards beamline)

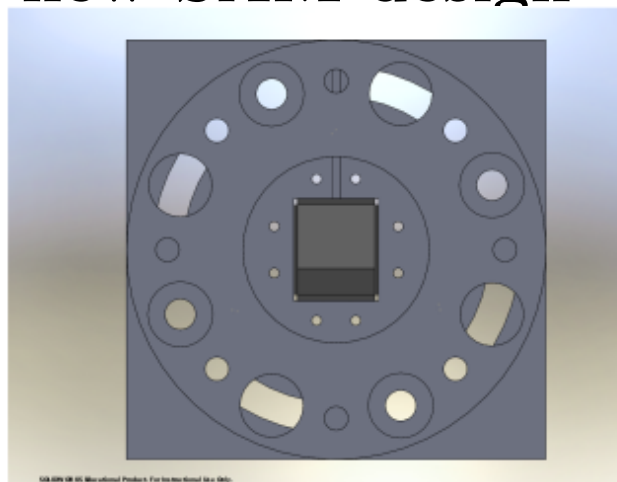

Radial View (looking up the LG away from beamline)

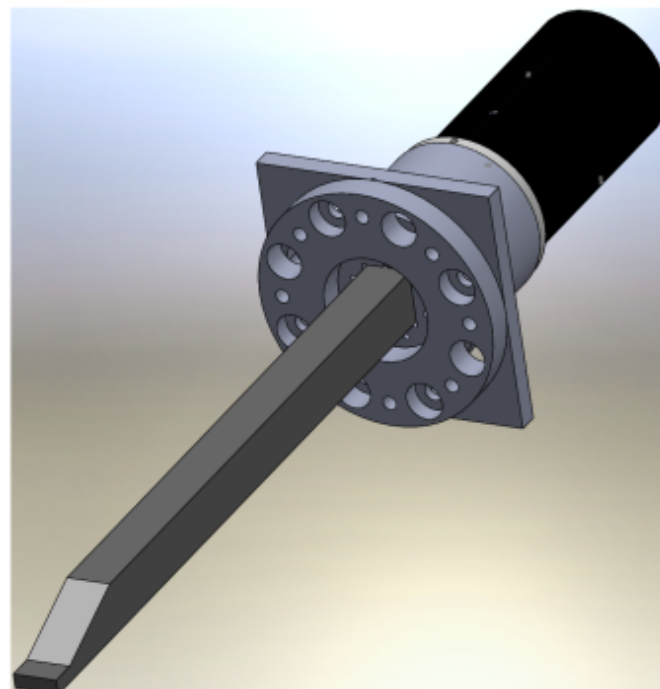

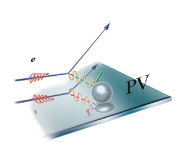

New SAM Lightguides



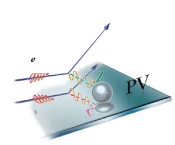

Photos of new SAM parts at SLAC

Electronic
Shutter for
SAMs

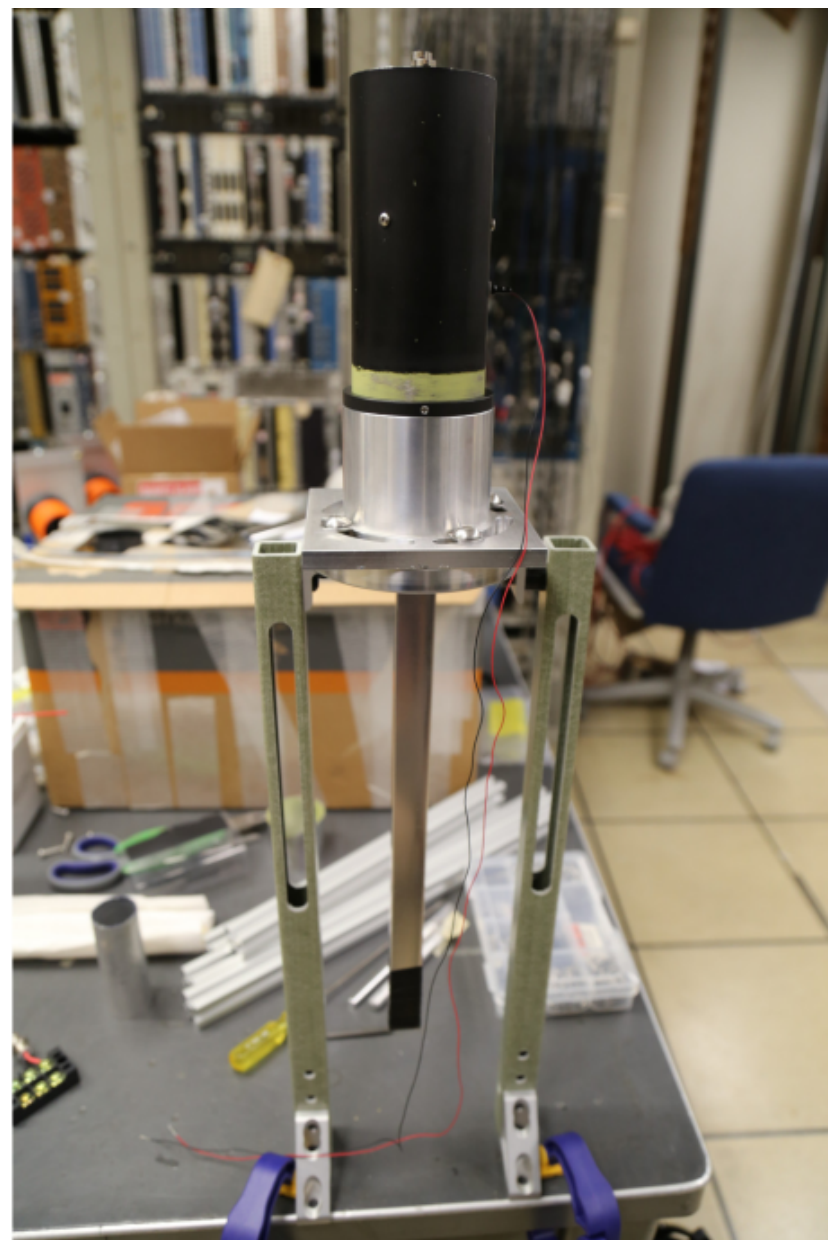
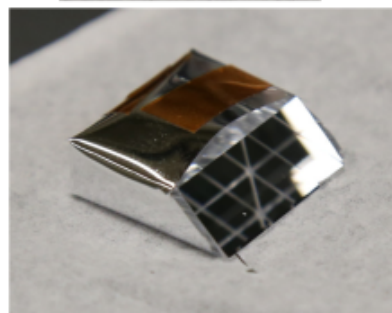
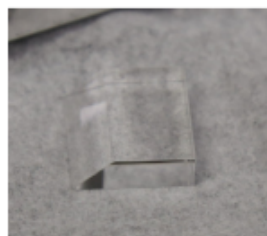
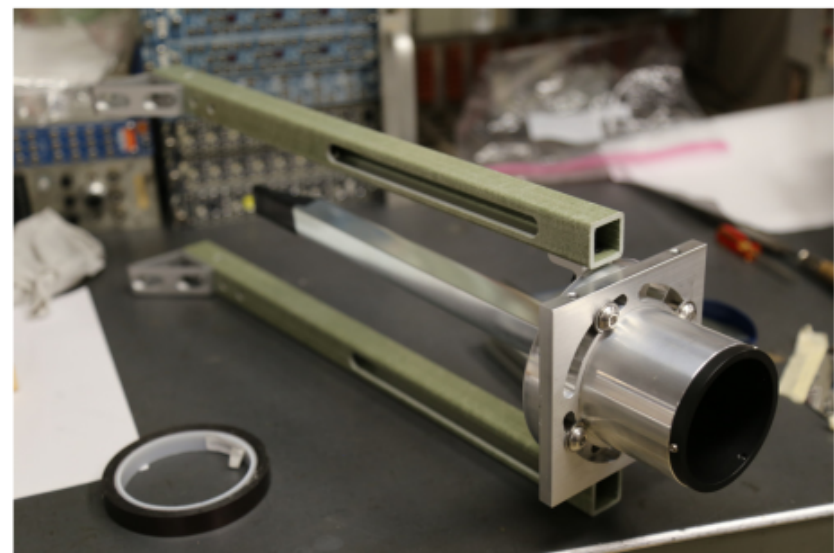
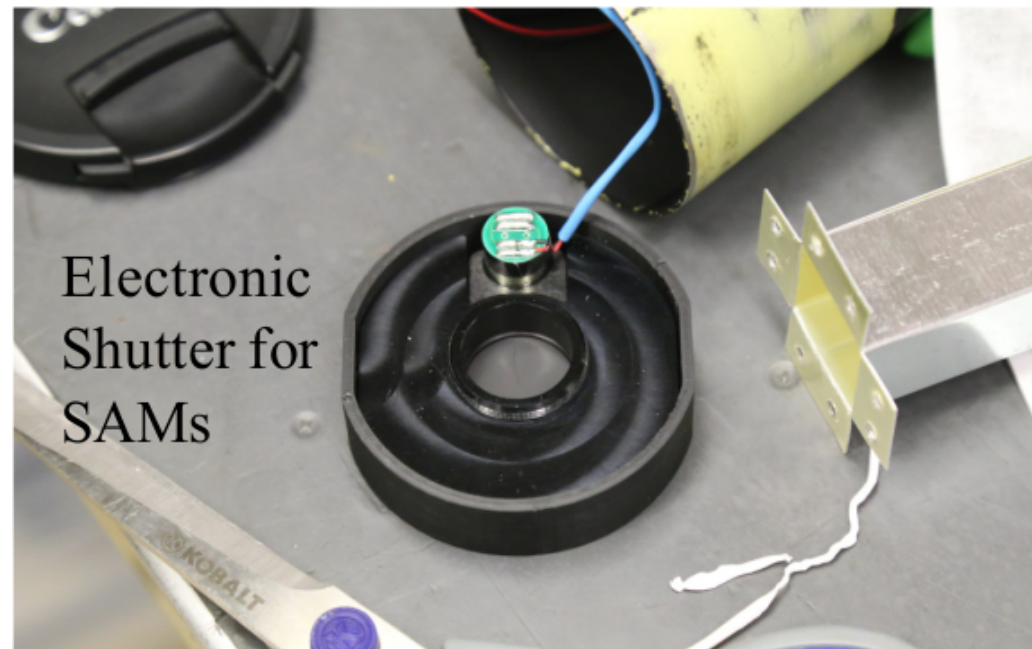

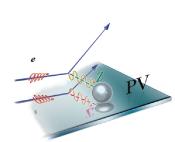

SLAC Testbeam Setup for SAM

Drawing of original setup idea for SAM beamtests at SLAC ESTB

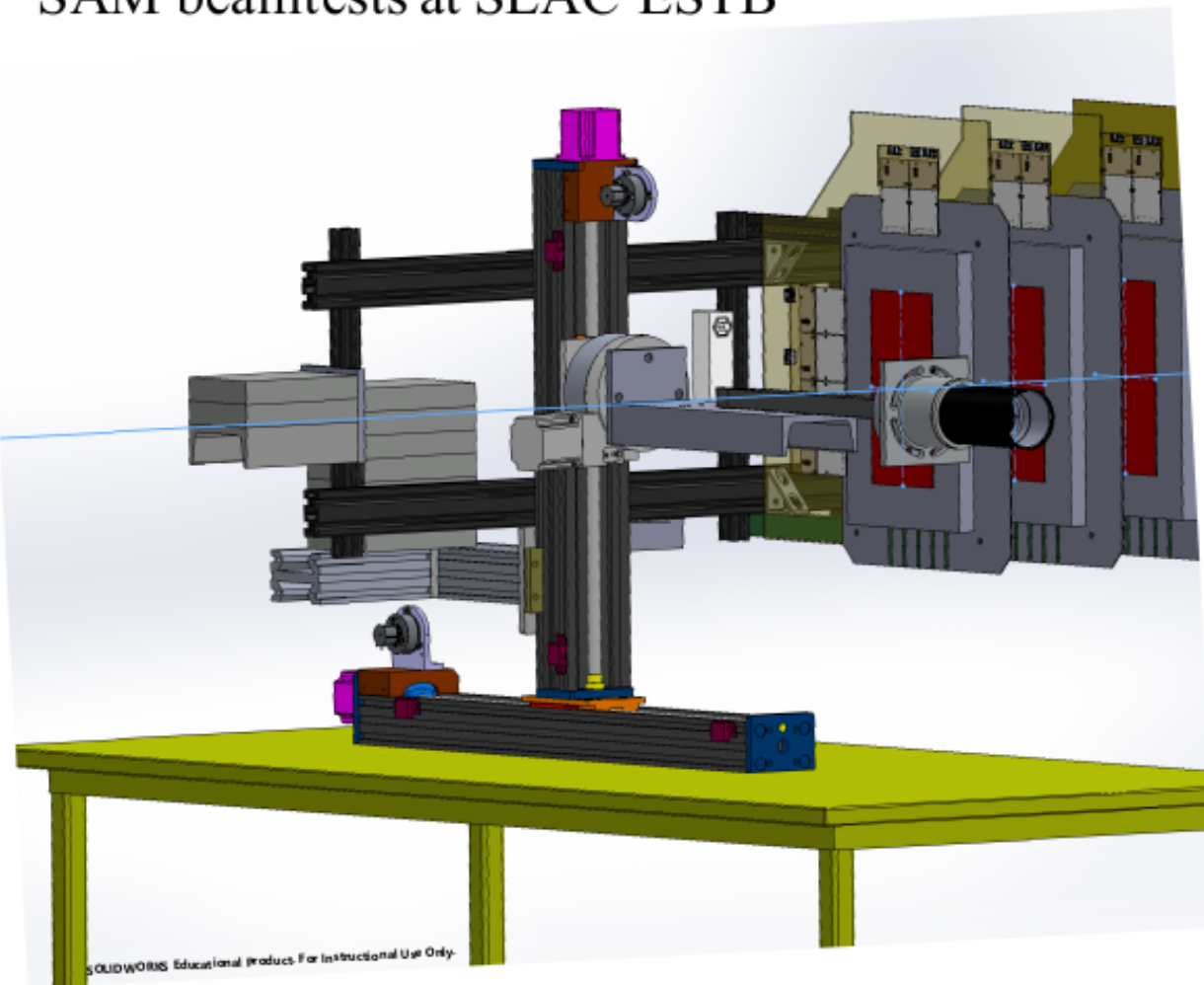
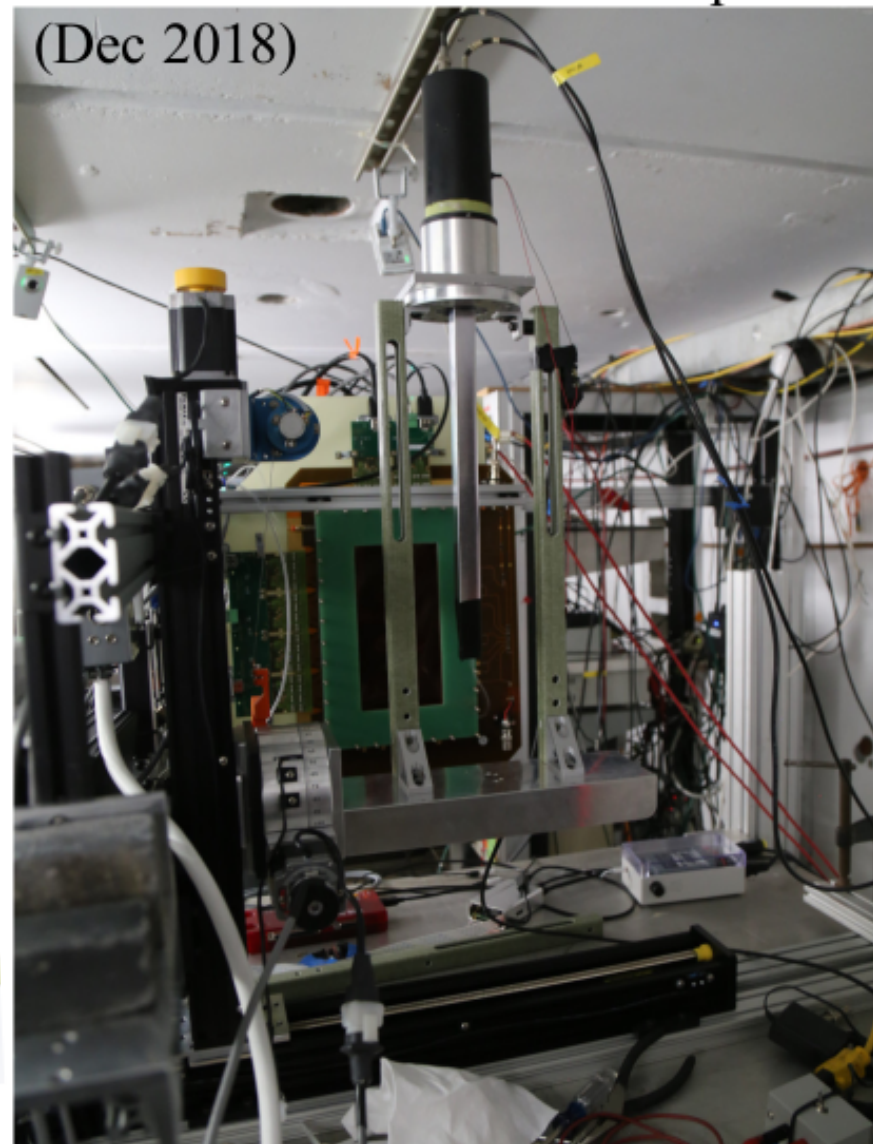
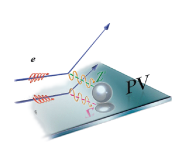

Photo of SAM testbeam setup (Dec 2018)





Summary (construction)

- New light guides designed. Sent to shop in November and folded in December 2018; have 10 in hand
- New insertion tube design finalized in Nov/Dec 2018 (fabricated at ANL for \sim \$10k); leak-tested and Meekins approved?; should have all 8 in hand by end of the month
- 10 new SAM quartz pieces (\$4k) delivered in Nov 2018
- Electronic shutter system designed for new SAMs. Installed and \sim successfully tested at SLAC; do not know radiation hardness or failure mode yet; developing shutter control system now; may remove shutters after initial commissioning
- SLAC plans to benchmark new SAMs failed (for a few reasons): first, the high sensitivity range on QDC was not setup properly, second, it was very difficult to put the beam on the small SAM quartz, and third, we ran out of time

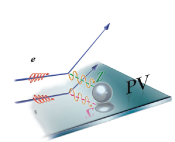

Summary (installation)

- All components will be ready for installation by mid March; will coordinate expected install date with Jesse and radcon through an HAList/atlis submission
- The HRSs need to be moved to larger angle for installation
- The beamline (near SAMs) must be brought up to atmosphere
- Coordinating with RadCon, the old SAM assemblies will be removed from beamline; the lightguides and quartz can be stored if activated
- The old insertion tubes will be removed and replaced with new ones; can likely reuse hardware as well as vacuum seal flanges
- Install new SAMs
- Reconfigure preAmps – may need some additional Qwak preAmps here

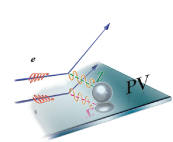

The MOLLER Project at Jefferson Lab:

Measurement of

Lepton

Lepton

Electroweak

Reaction

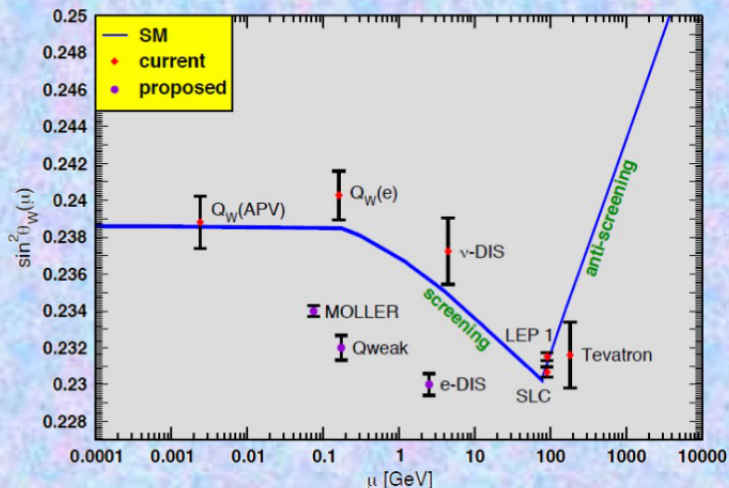
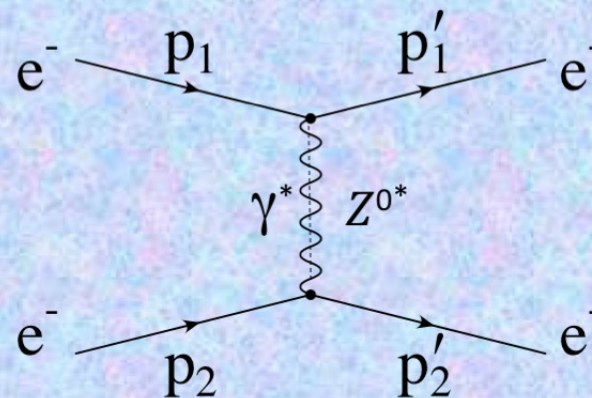

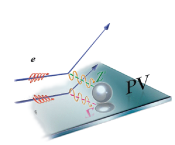

Møller Scattering A_{PV} Measurement

- MOLLER aimed at precision measurement of parity-violating asymmetry A_{PV} in polarized electron-electron scattering.
- Standard Model gives precise prediction for Møller A_{PV} –which can be measured as a test.

$$A_{PV} = \frac{\sigma_R - \sigma_L}{\sigma_R + \sigma_L} = \frac{M_\gamma M_Z}{M_\gamma^2} = m_e E_{lab} \frac{G_F}{\sqrt{2}\pi\alpha} \frac{4\sin^2\theta_{lab}}{(3 + \cos^2\theta_{lab})^2} Q_W^e,$$

$$Q_W^e \equiv 4 \cdot g_V^e \cdot g_A^e = -(1 - 4\sin^2\theta_W) \tag{1}$$

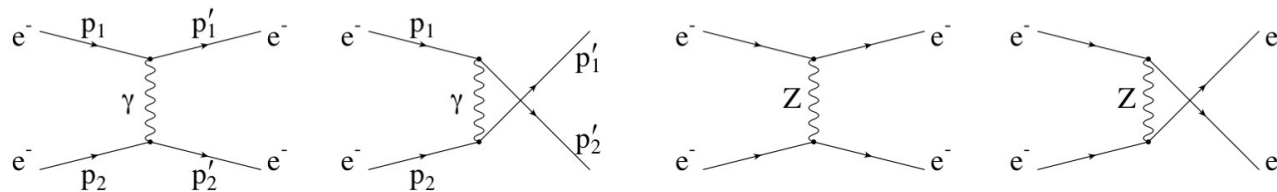

Feynman diagrams for Moller Scattering at tree level

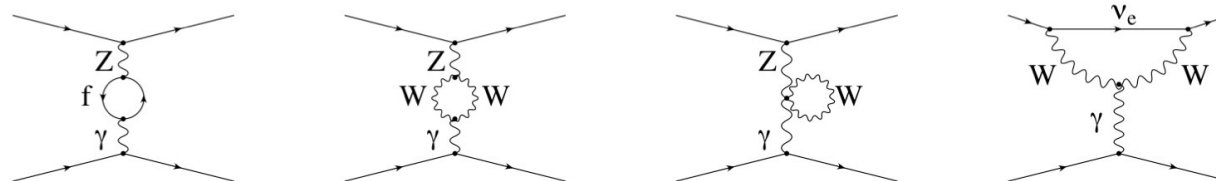

γ - Z mixing diagrams and W loops. “Hard” radiative corrections involving the massive vector bosons—modify the tree level prediction significantly.

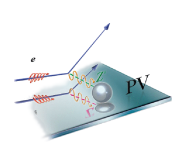

The MOLLER A_{PV} Measurement

- At proposed kinematics: $11\text{GeV } e_{\text{beam}}^-$ ($75\mu\text{A}$, $80\% P_e$), and $5\text{mrad} < \theta_{lab} < 20\text{mrad}$:
→ Predicted $\langle A_{PV} \rangle = 36\text{ppb}$ at $\langle Q^2 \rangle = 0.0056 \text{ (GeV/c)}^2$
- For 49 (PAC) week run: $\delta A_{PV} = 0.74\text{ppb}$:
→ $\delta Q_W^e / Q_W^e = \pm 2.1\%(\text{stat}) \pm 1.0\%(\text{syst})$
→ $\delta \theta_W = \pm 0.00026(\text{stat}) \pm 0.00012(\text{syst}) \sim 0.1\%$ precision!

Challenging 4th generation measurement requiring:

- Unprecedented precision matching of electron beam characteristics for Left versus Right helicity states
- Precision non-invasive, redundant continuous beam polarimetry
- Precision knowledge of luminosity, spectrometer acceptance (Q^2) and backgrounds

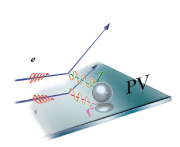

MOLLER Motivations

Ultra-precise (~0.1%) measurement of weak mixing angle will test SM

Running of $\sin^2\theta_W$: complicated and scheme-dependent – many orders in loops of all particles

6s → 7s ¹³³Cs atomic transition

Major improvements for near future

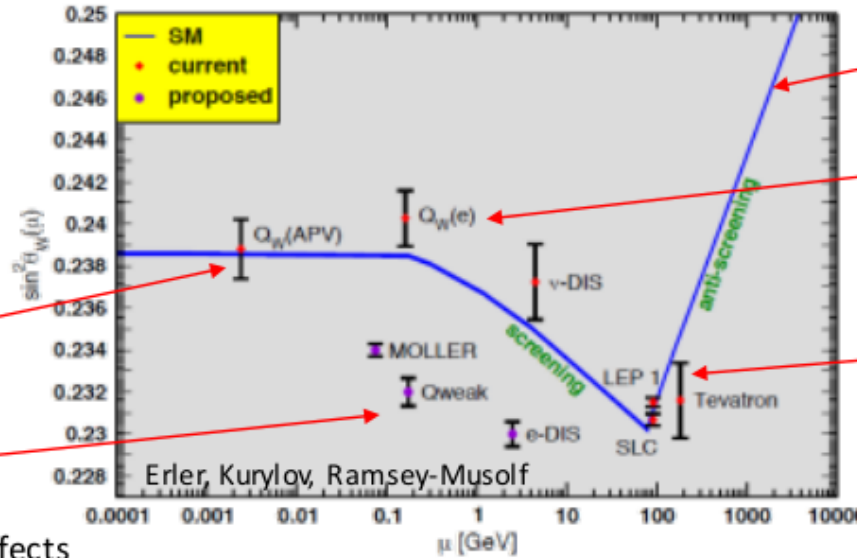

Electroweak fit with uncertainty

Parity violating Moller scattering (E158)

Collider experiments near Z-pole (most precise 0.1%)

- ❖ Sensitivity to radiative loop effects of new particles predicted by MSSM

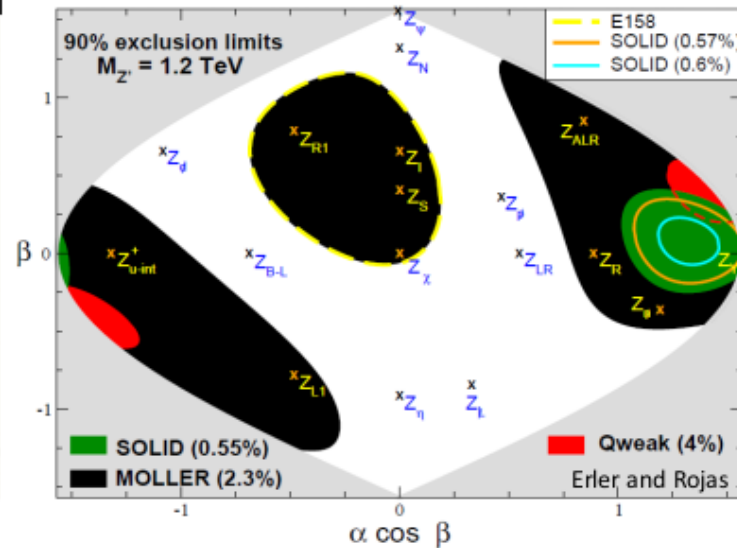
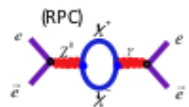
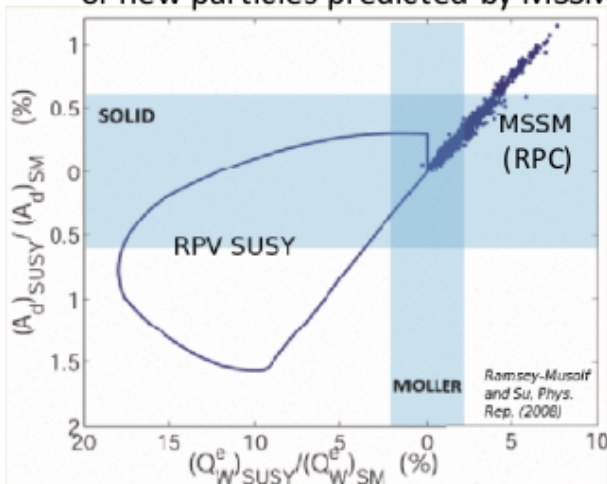

- ❖ MOLLER can help discriminate between competing GUT models which predict new 1 – 2 TeV Z's

- ❖ Probe potential kinetic-mixing of super-light (10 to 500 MeV) dark Z bosons with SM Z

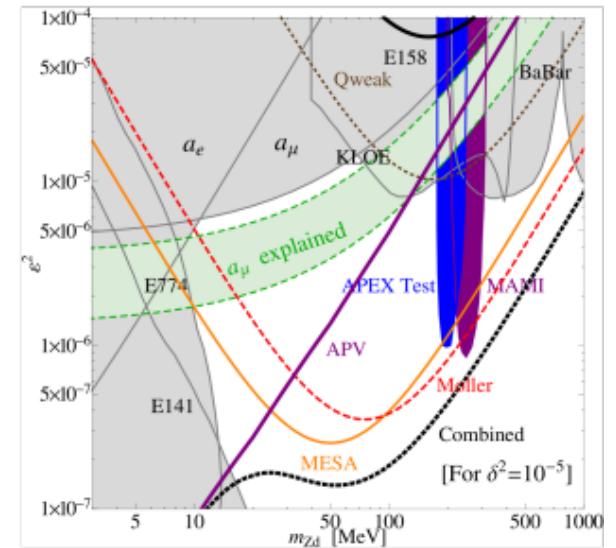

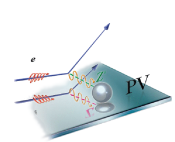

MOLLER Apparatus

(major new installation experiment for Hall A)

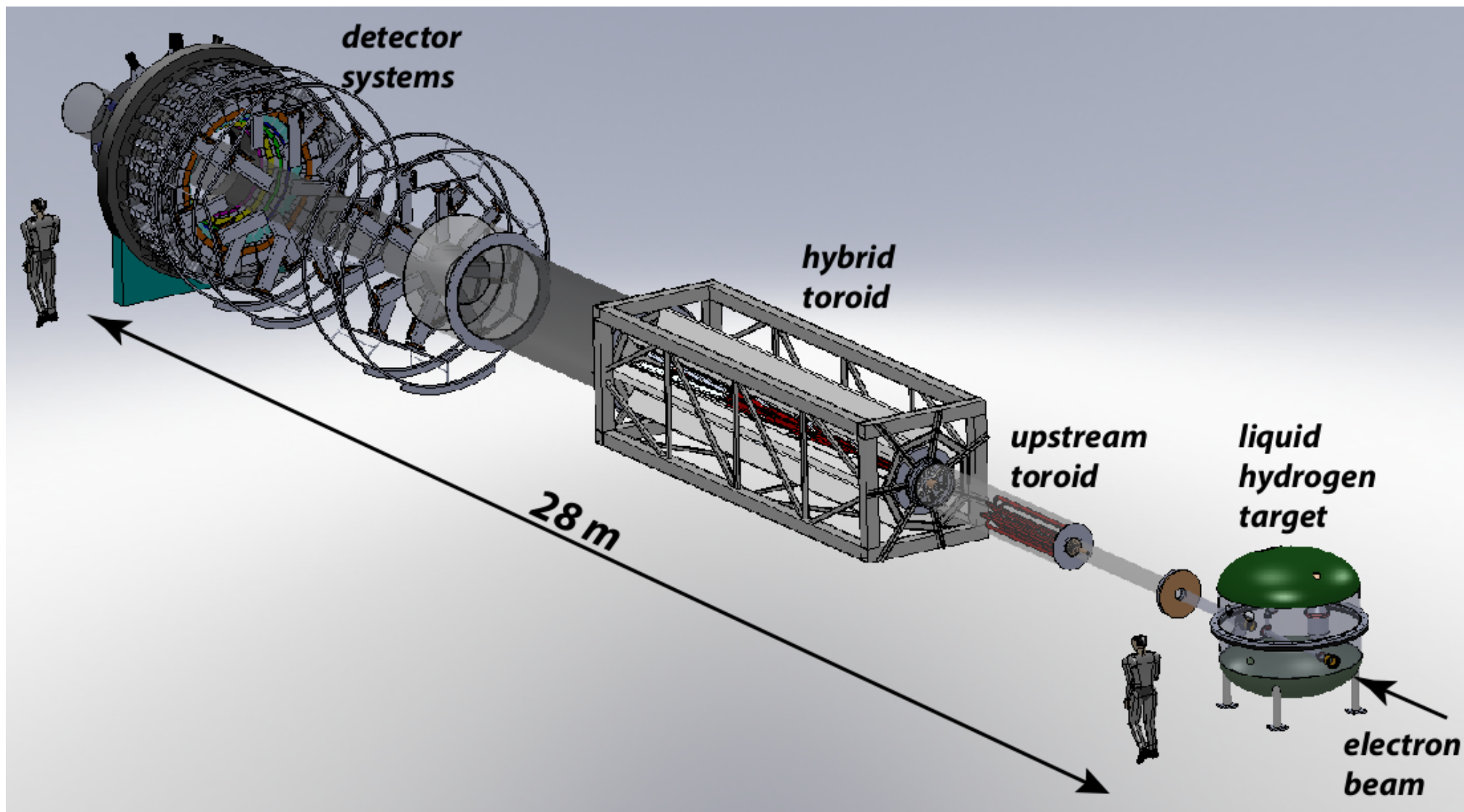

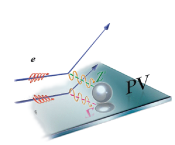

Optimized Spectrometer ($\sim 100\%$ Acceptance)

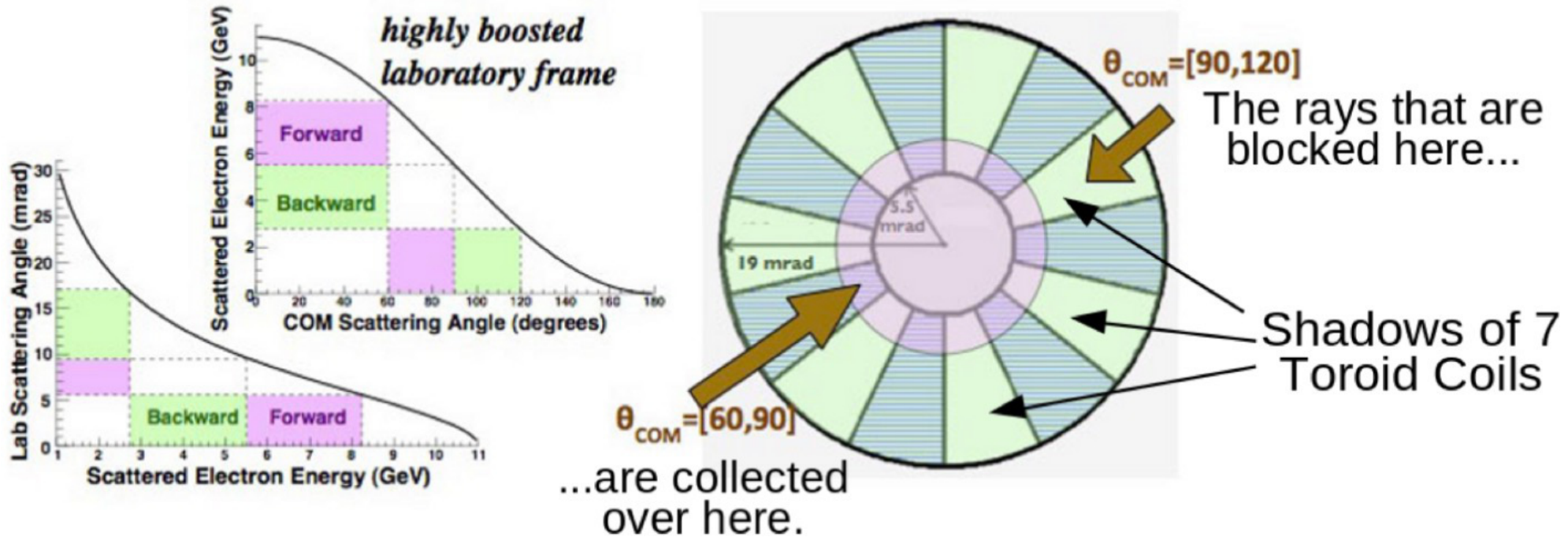

- The combination of a toroidal magnetic system with an odd number of coils together with the symmetric, identical particle scattering nature of the Møller process allows for $\sim 100\%$ azimuthal acceptance

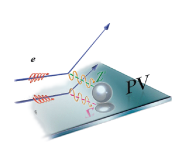

Toroid Design Concept

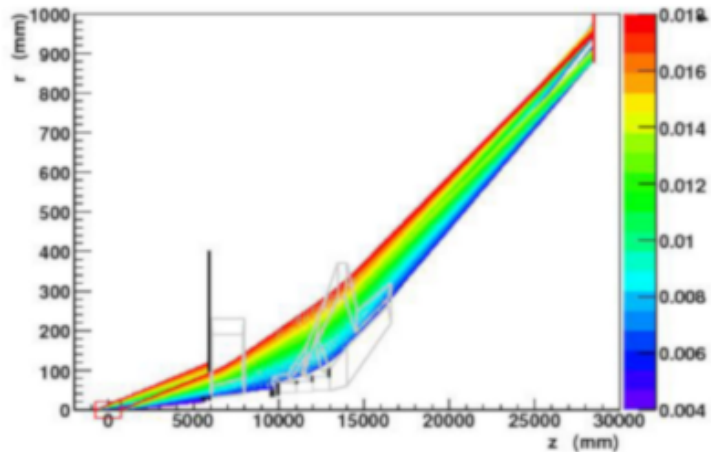

Projected radial coordinate of scattered Møller electron trajectories. Colors represent θ_{lab} (rad). Magnet coils (grey) and collimators (black) are overlaid.

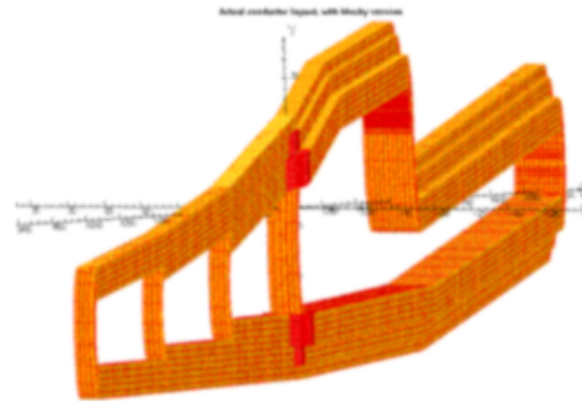

Single Hybrid coil shown with 1/10 scale in z direction. Note the 4 current returns give successively higher downstream fields.

- Spectrometer employs two back-to-back toroid magnets and precision collimation:
 - Upstream toroid has conventional geometry
 - Downstream “hybrid” toroid novel design inspired by the need to focus Møller electrons with a wide momentum range while separating them from e-p (Mott) scattering background

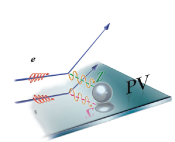

MOLLER Integrating Detector Layout and Rates

- Spectrometer separates signal from bkgd and radially focuses at detector plane
- Rates for 11 GeV/75 μ A (80% pol.) beam, 1.5m liquid hydrogen target. See fig. \rightarrow
- Six radial rings, 28 phi segments per ring*
- Ring 5 intercepts Moller peak (\sim 150 GHz), Ring 2 intercepts bkgd "ep" peaks
- 250 quartz tiles: allow full characterization and deconvolution of bkgd and signal processes

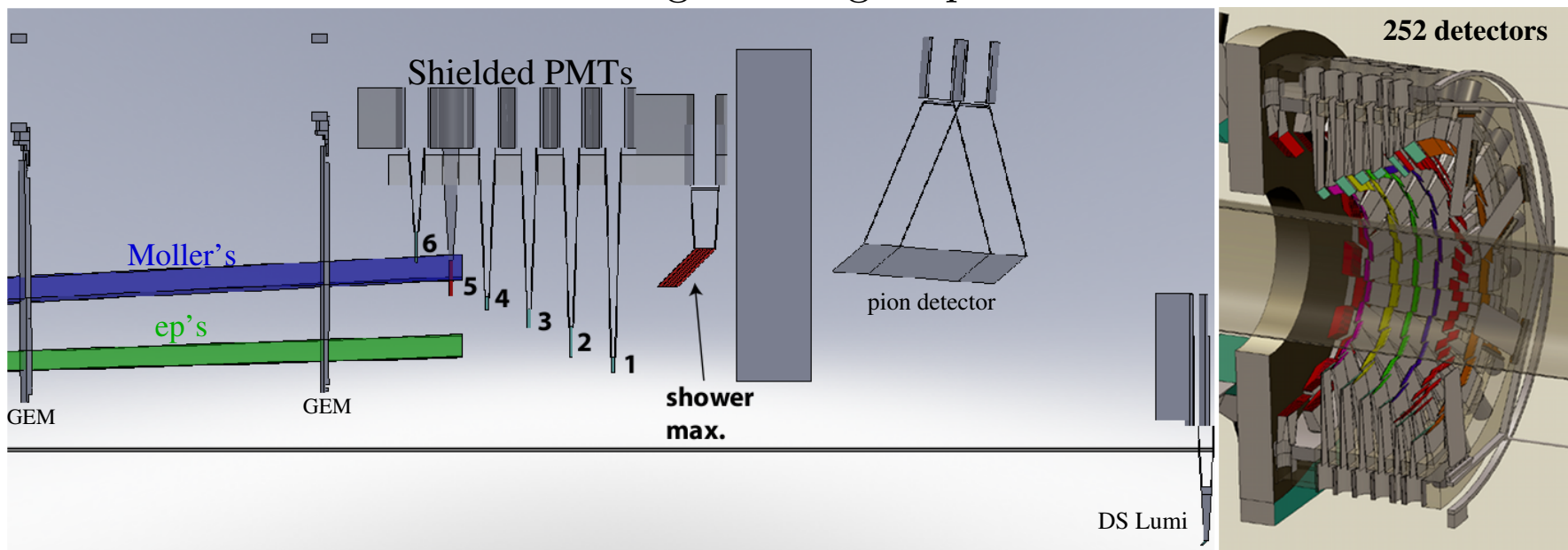
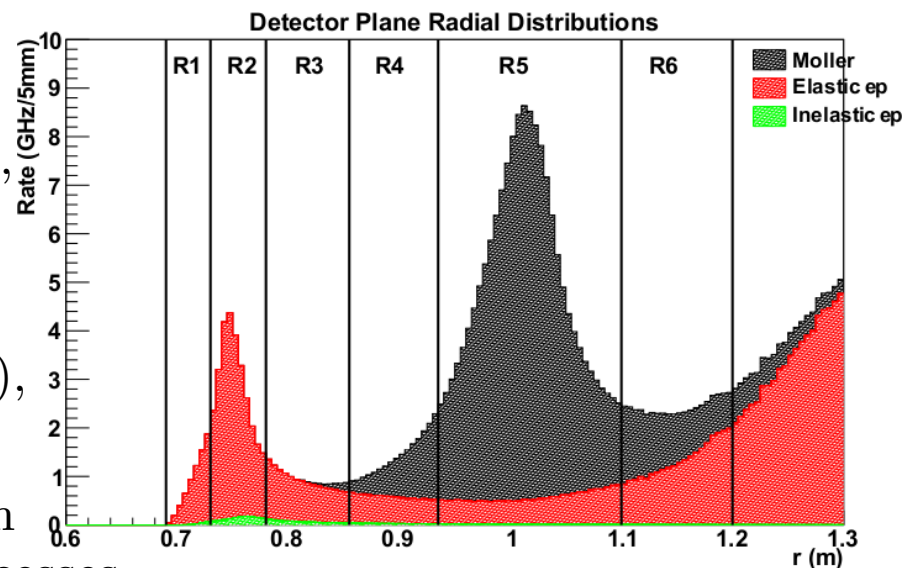

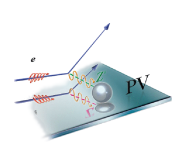

Shower-max Motivation & Requirements

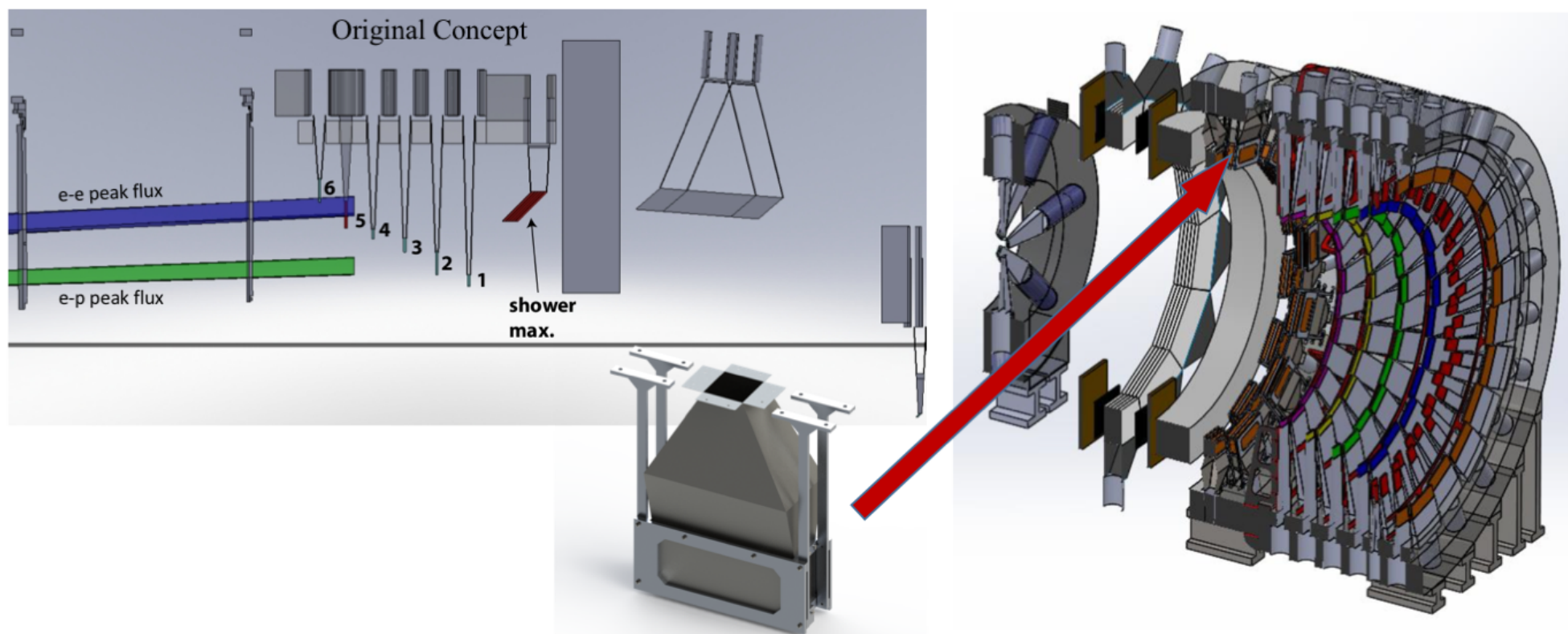

- Provides additional measurement of e-e ring integrated flux
- Weights flux by energy \Rightarrow less sensitive to low energy and hadronic backgrounds
- Will also operate in tracking mode to give additional handle on background (pion) identification – gives MIP-like signal
- Should have good resolution over full energy range ($\frac{\sigma}{\langle n \rangle} \lesssim 25\%$), long term stability and be radiation hard

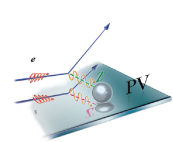

Baseline ShowerMax Design and Ring Concept

Open region (original) Baseline Design

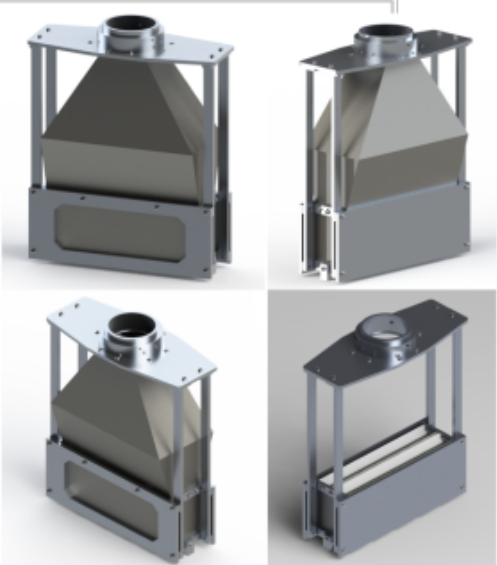
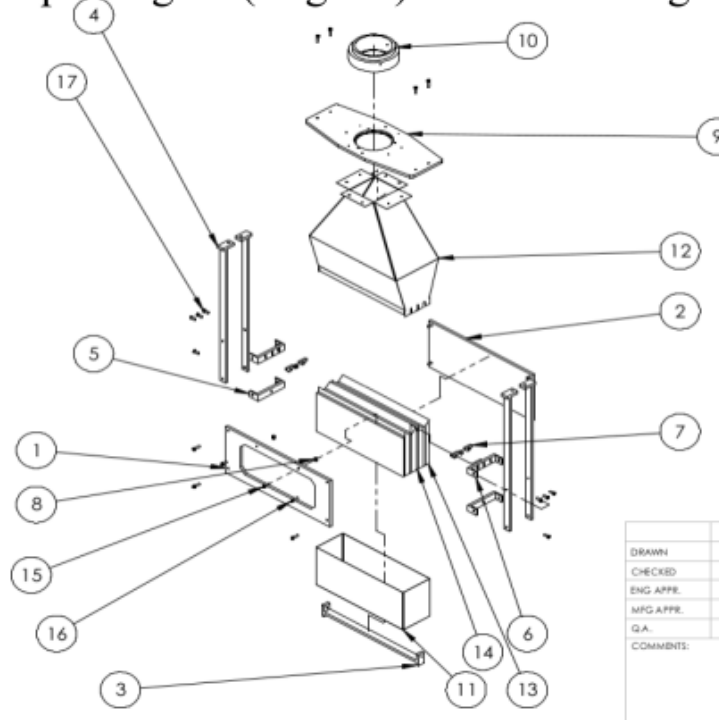

Idaho State University		
NAME	DATE	
DS	05/16	
TITLE:		
EXPLODED VIEW		
SIZE	DWG. NO.	REV
A	II	A
SCALE: 1:5		SHEET 2 OF 17

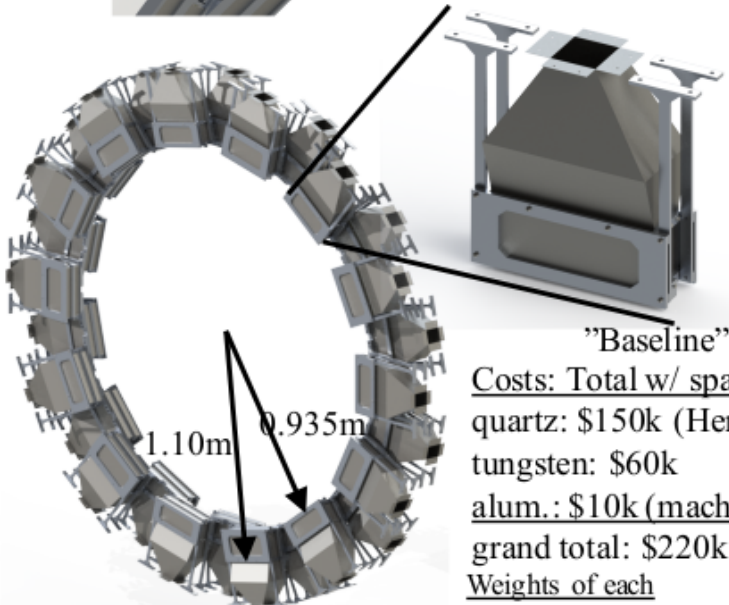
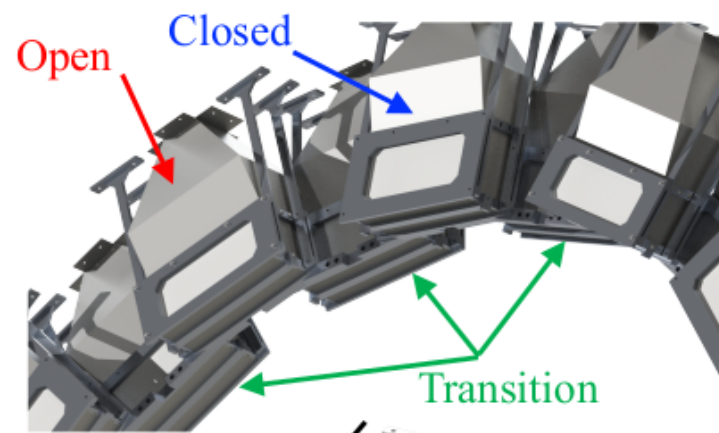

"Baseline"
 Costs: Total w/ spares
 quartz: \$150k (Heraeus)
 tungsten: \$60k
 alum.: \$10k (machined)
 grand total: \$220k
Weights of each assembly:
 Open: 39.7 lbs.
 Transition: 42.5 lbs.
 Closed: 50.8 lbs.
 ring weight: 1230 lbs.

- Engineered shop drawings for full-scale prototypes in hand
- **PLANS**: Finalized prototype Stack designs last fall and ordered prototype quartz in Nov 2017, construct in winter/spring 2018 and test in summer/fall using 2 - 10 GeV electron SLAC testbeam
- Shower-max ring design concept: staggered in \hat{z} with reinforced struts and brackets. 28 detectors in ring: 7 Open, 7 Closed, and 14 Transition

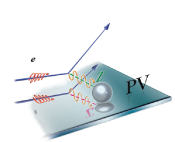

Prototype Designs for Testbeam

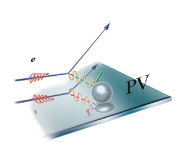

Shower-max Benchmarking Prototype concept

- Concept allows stack to be assembled and beam-tested one piece at a time for detailed benchmarking study
- Fabricated with ABS plastic using 3D printer

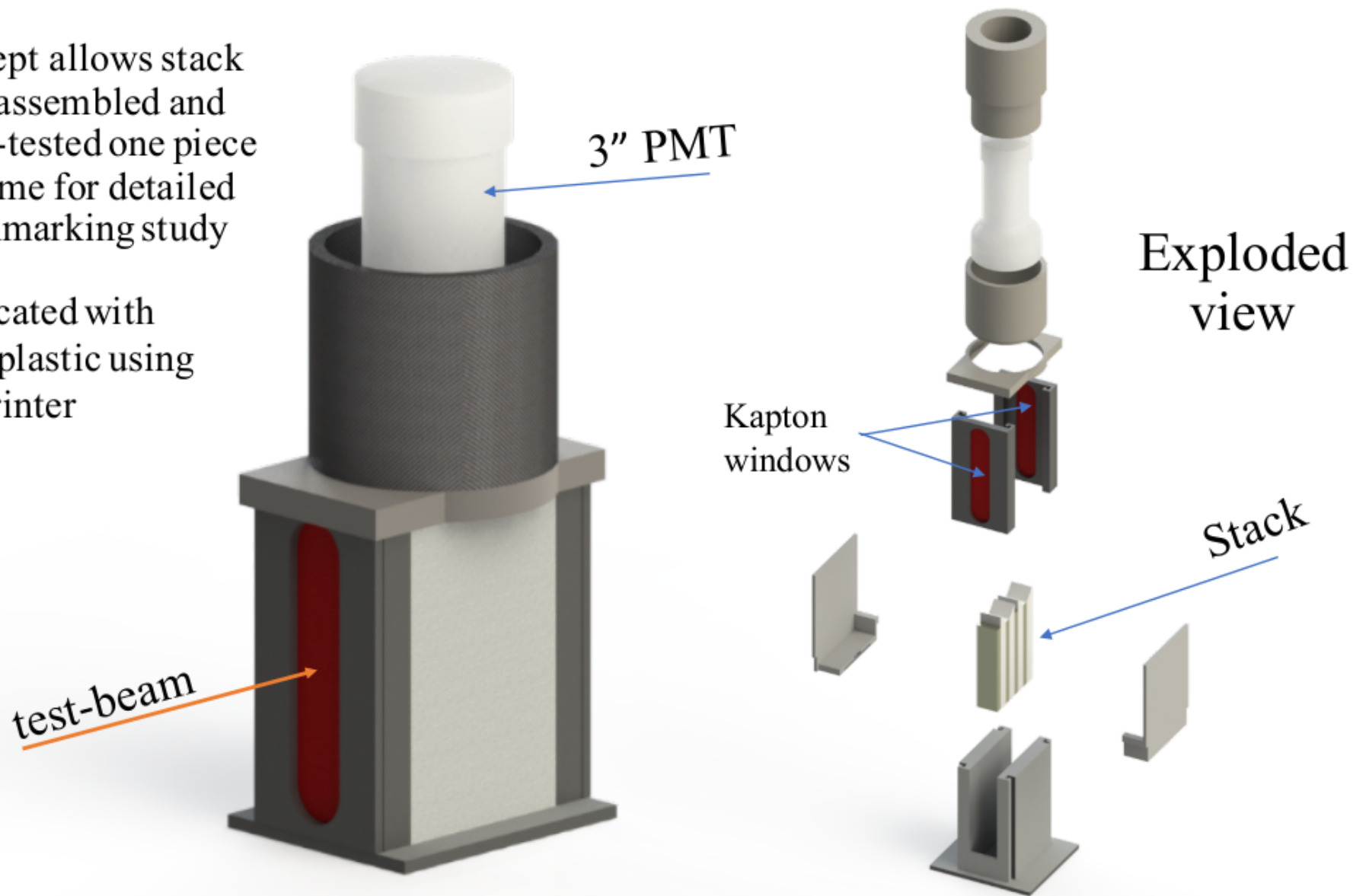

Config #1 (original baseline) benchmarking Prototype

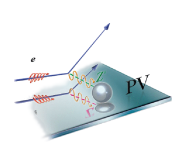

Benchmarking Stack Configurations

Highlighted columns show changes due to quartz thickness change: **Examined 6 mm and 10 mm thick tiles**

Config #	t_f (mm)	t_q (mm)	t_w (mm)	b (mm)	a (mm)	X_0	R_{molier} (mm)
1A	8	10	8	64	44	9.5	11.0
2A	17	10	5	55	55	9.5	11.0
3A	14	10	6	58	52	9.5	11.0
4A	6	10	6	58	52	7.3	11.5

Config #	t_f (mm)	t_q (mm)	t_w (mm)	b (mm)	a (mm)	X_0	R_{molier} (mm)
1B	8	6	8	48	61	9.5	11.0
2B	17	6	5	39	67	9.5	11.0
3B	14	6	6	42	65	9.5	11.0
4B	6	6	6	42	65	7.3	11.5

- ❖ Key benefit here is that the parameter “a” (the width of the benchmarking quartz tiles) can now be comfortably large to ensure negligible transverse shower leakage.

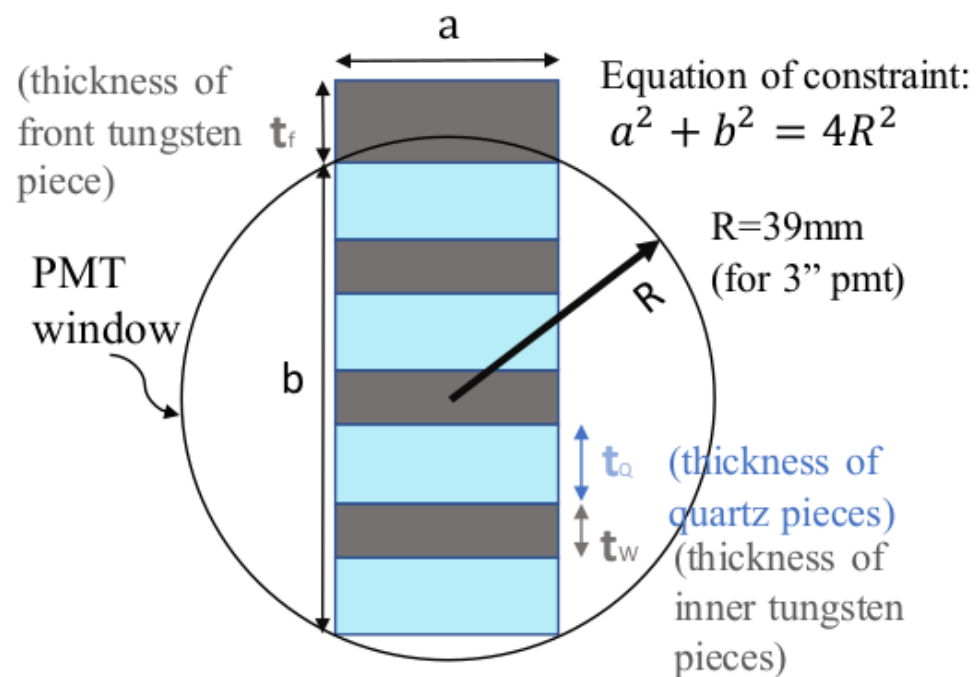

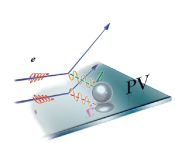

Updated Full-Scale Prototype (1A) for Testbeam

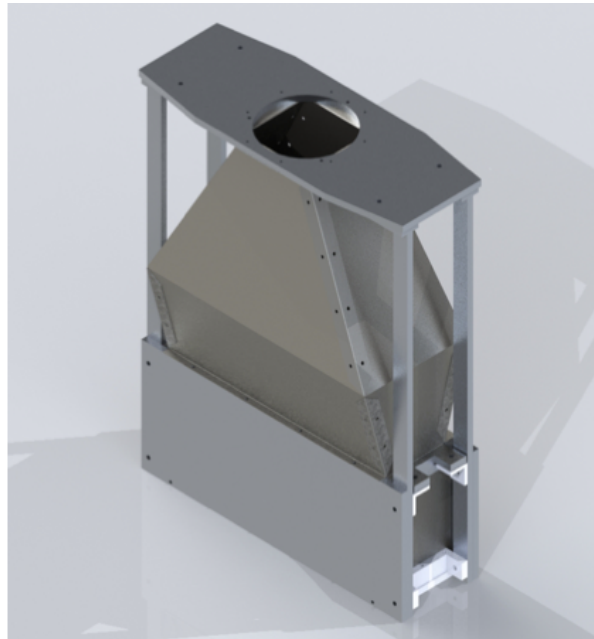
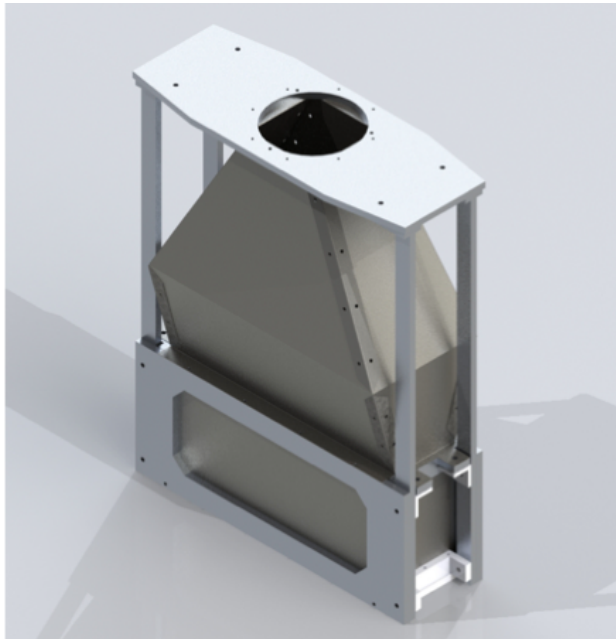

UNLESS OTHERWISE SPECIFIED:		NAME	DATE
DIMENSIONS ARE IN INCHES		DRAWN	DKS 1/14/18
TOLERANCES:		CHECKED	
FRACTIONAL ±		END APPR.	
ANGULAR: MACH ±		MFG APPR.	
TWO PLACE DECIMAL ±		Q.A.	
THREE PLACE DECIMAL ±		COMMENTS:	
INTERPRET GEOMETRIC TOLERANCING PER:			
MATERIAL:			

Moller Collaboration
TITLE: **Light Guide**

SIZE **A** DWG. NO. **I** REV **0**
SCALE: 1:10 WEIGHT: SHEET 1 OF 9

ITEM NO.	PART	MATERIAL	QTY.
1	Light Guide - Back	0.001 ANODIZED MIRROR SILVER REFLECTIVE ALUMINUM SHEET	1
2	Light Guide - Front	0.001 ANODIZED MIRROR SILVER REFLECTIVE ALUMINUM SHEET	1
3	Long Flap	0.001 ANODIZED MIRROR SILVER REFLECTIVE ALUMINUM SHEET	2
4	Short Flap	0.001 ANODIZED MIRROR SILVER REFLECTIVE ALUMINUM SHEET	4
5	Suitcase	0.001 ANODIZED MIRROR SILVER REFLECTIVE ALUMINUM SHEET	2

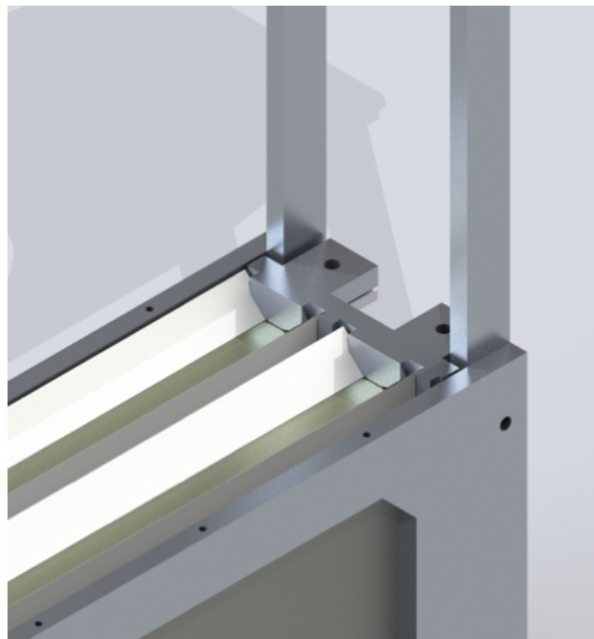
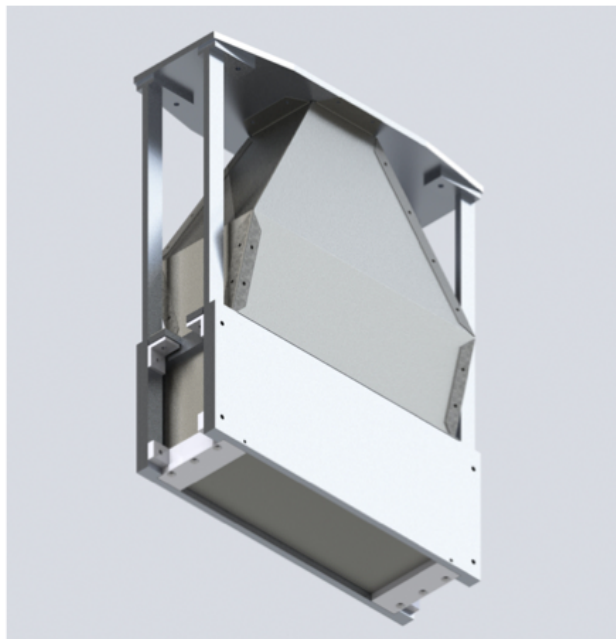

UNLESS OTHERWISE SPECIFIED:		NAME	DATE
DIMENSIONS ARE IN INCHES		DRAWN	DKS 1/14/18
TOLERANCES:		CHECKED	
FRACTIONAL ±		END APPR.	
ANGULAR: MACH ±		MFG APPR.	
TWO PLACE DECIMAL ±		Q.A.	
THREE PLACE DECIMAL ±		COMMENTS:	
INTERPRET GEOMETRIC TOLERANCING PER:			
MATERIAL:			

Moller Collaboration
TITLE: **Exploded View**

SIZE **A** DWG. NO. **II** REV **0**
SCALE: 1:10 WEIGHT: SHEET 2 OF 9

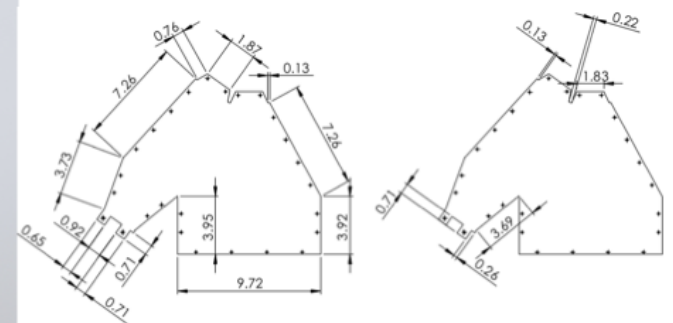

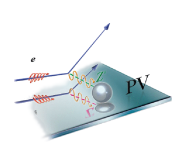

1A - 4A Mean PE and Resolution versus Energy

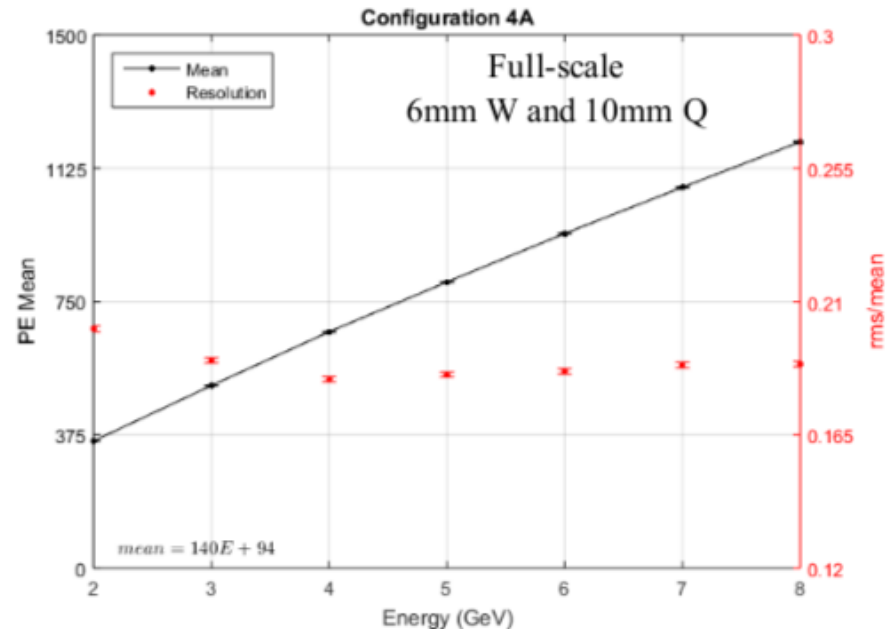
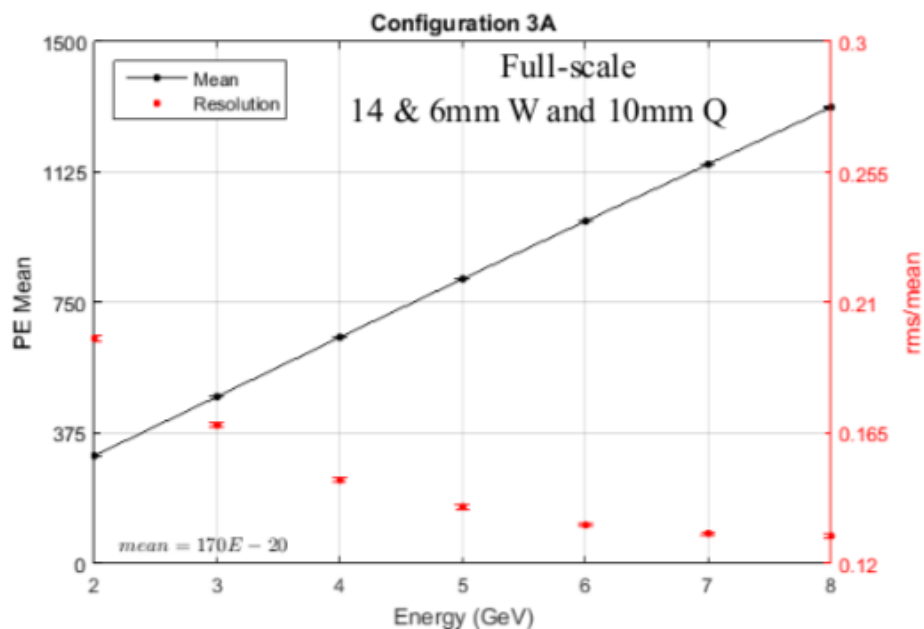
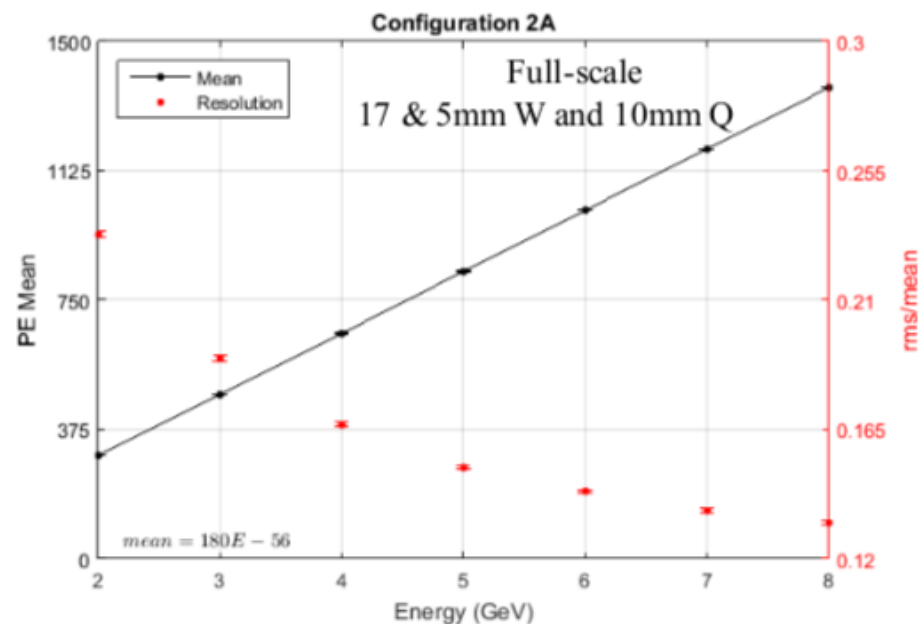
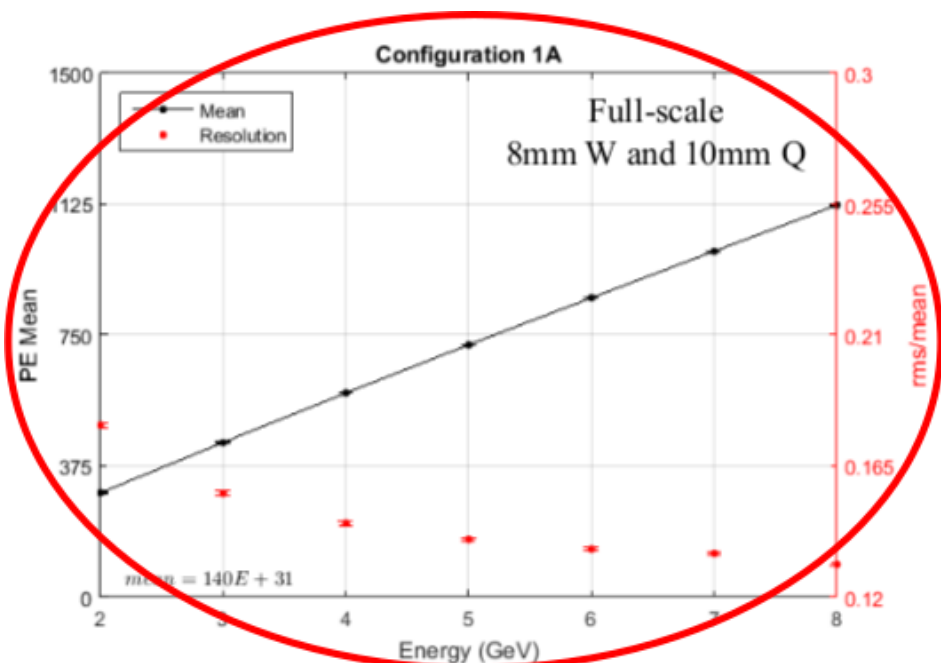

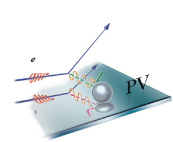

Simulation results for B configs (6mm quartz)

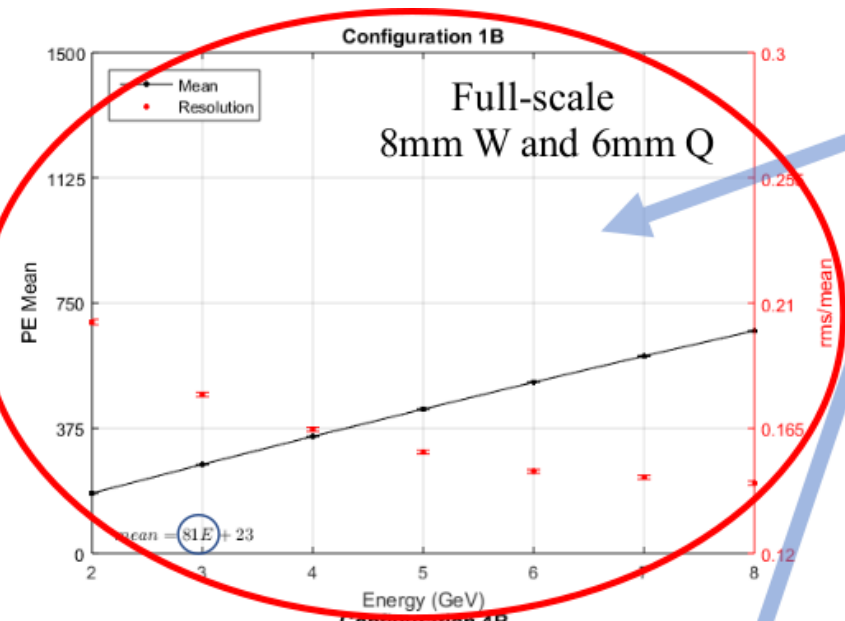

- The B configs have ~half the slope of the other configs – 80 PE/GeV – while maintaining good resolution and with lower light levels.
- The reduced slope means less variation in PE yields with energy--which will reduce the widths measured during helicity window (it seems a potential win win win situation)
- Also interesting is that if you reduce the layers of tungsten to 4mm, the resolution worsens ~drastically (even with 10 mm quartz)

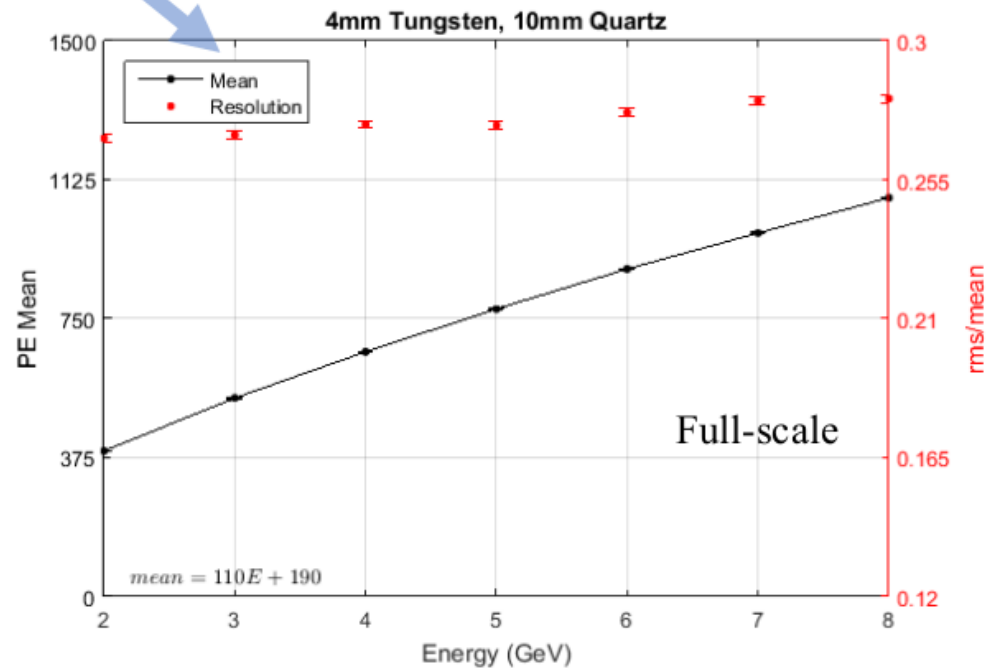
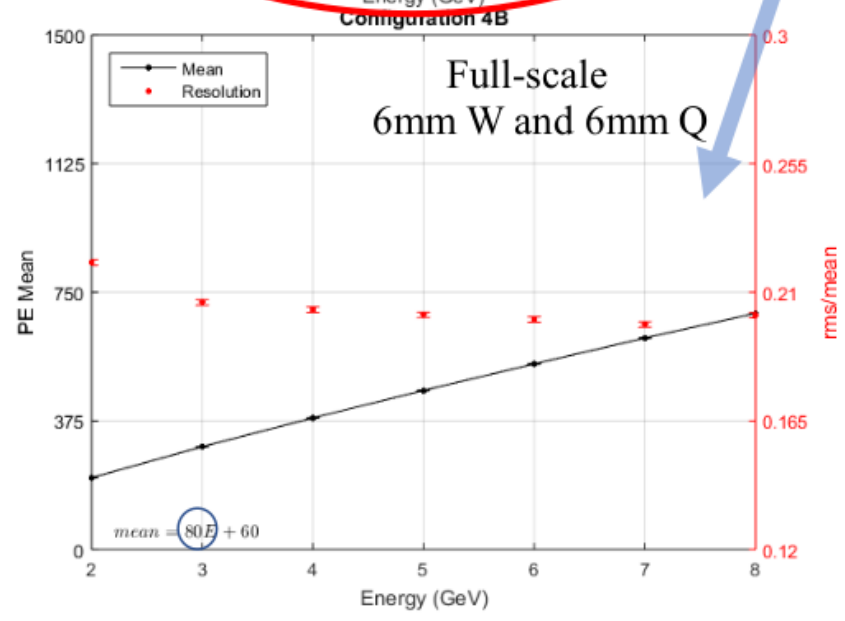

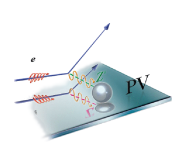

Prototype Construction and SLAC Testbeam Run

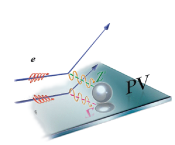

1A Full-scale Stack Assembly at SBU, June 2018

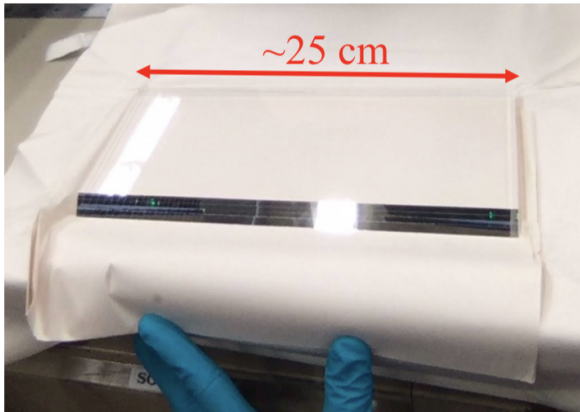

~25 cm

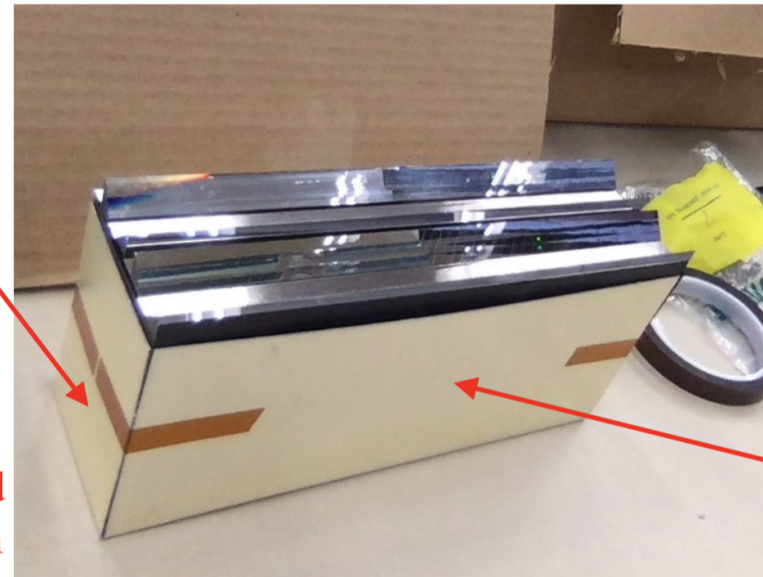

Aluminum sheet coffin

Fully assembled stack weighs ~40 lbs



Quartz wrapped in black Kapton

8 mm thick 99.95% pure tungsten plates

July 16, 2018

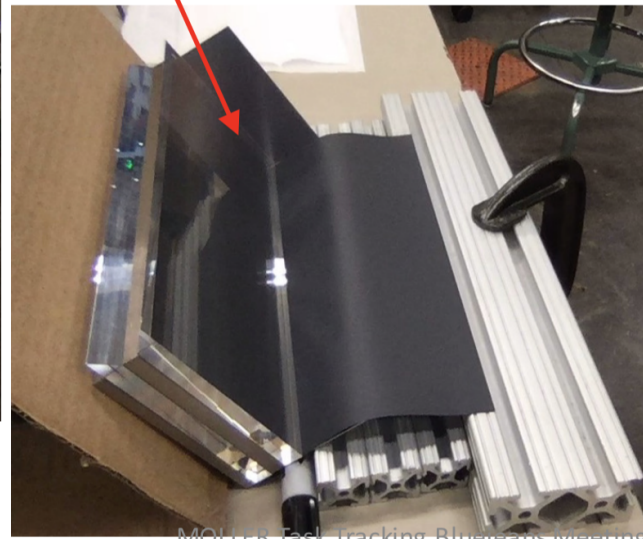

MOLLER Task Tracking Bluejeans Meeting

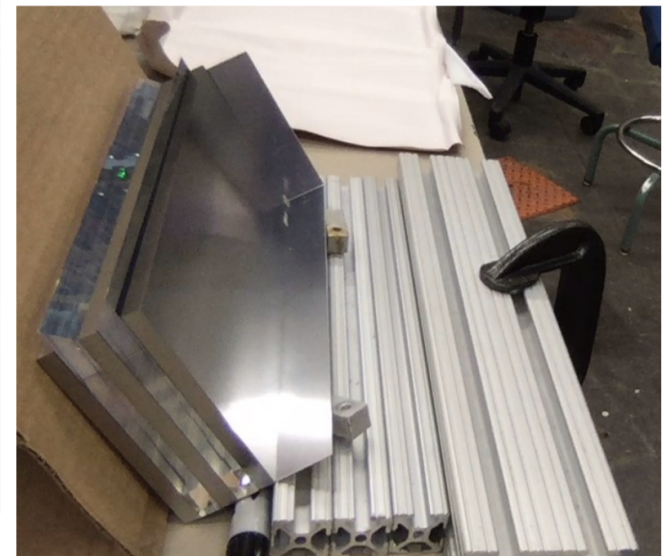

15

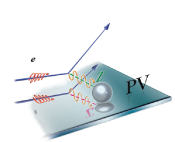

Assembled 1A Full-scale ShowerMax Prototype

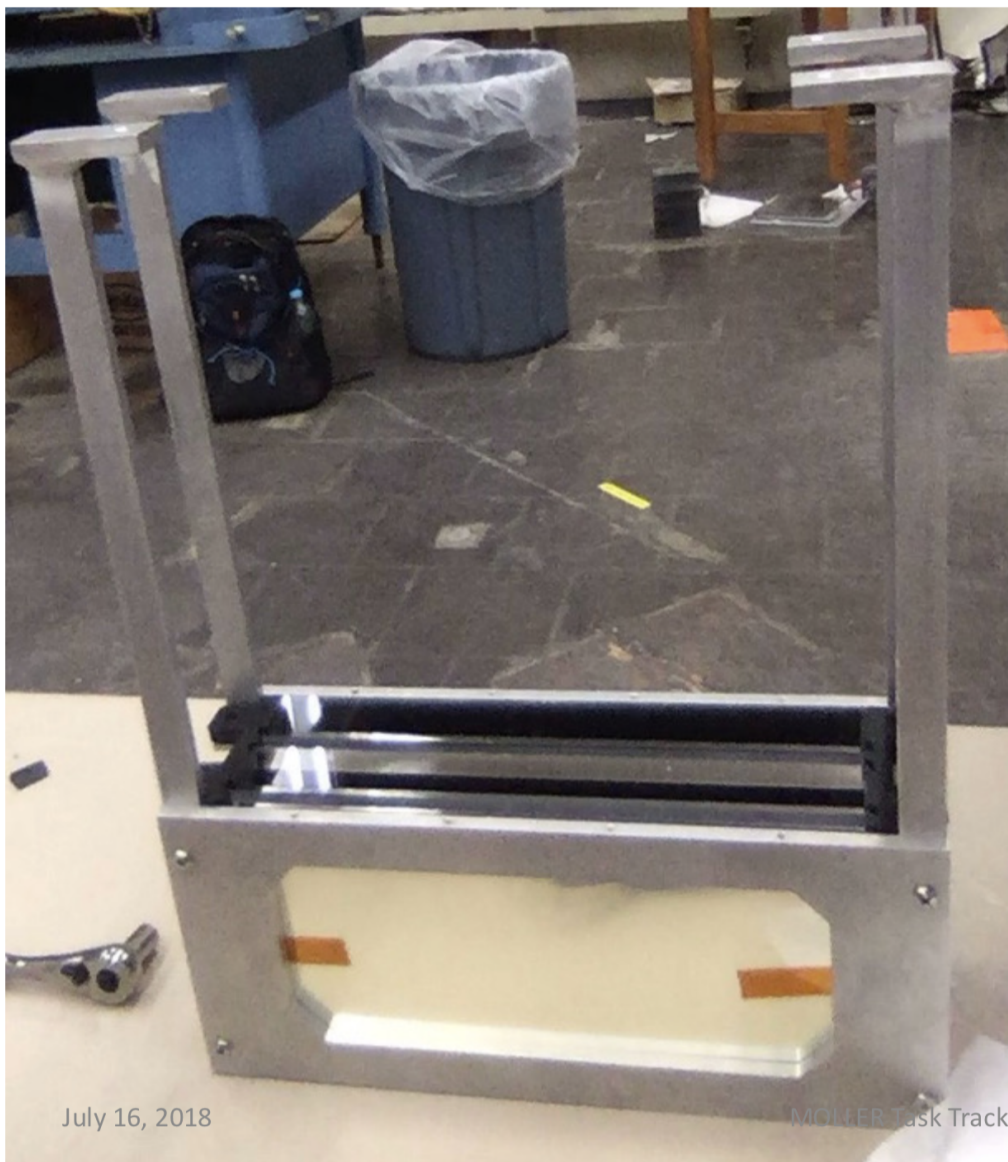

July 16, 2018

MOLLER Task Tracking Bluejeans Meeting

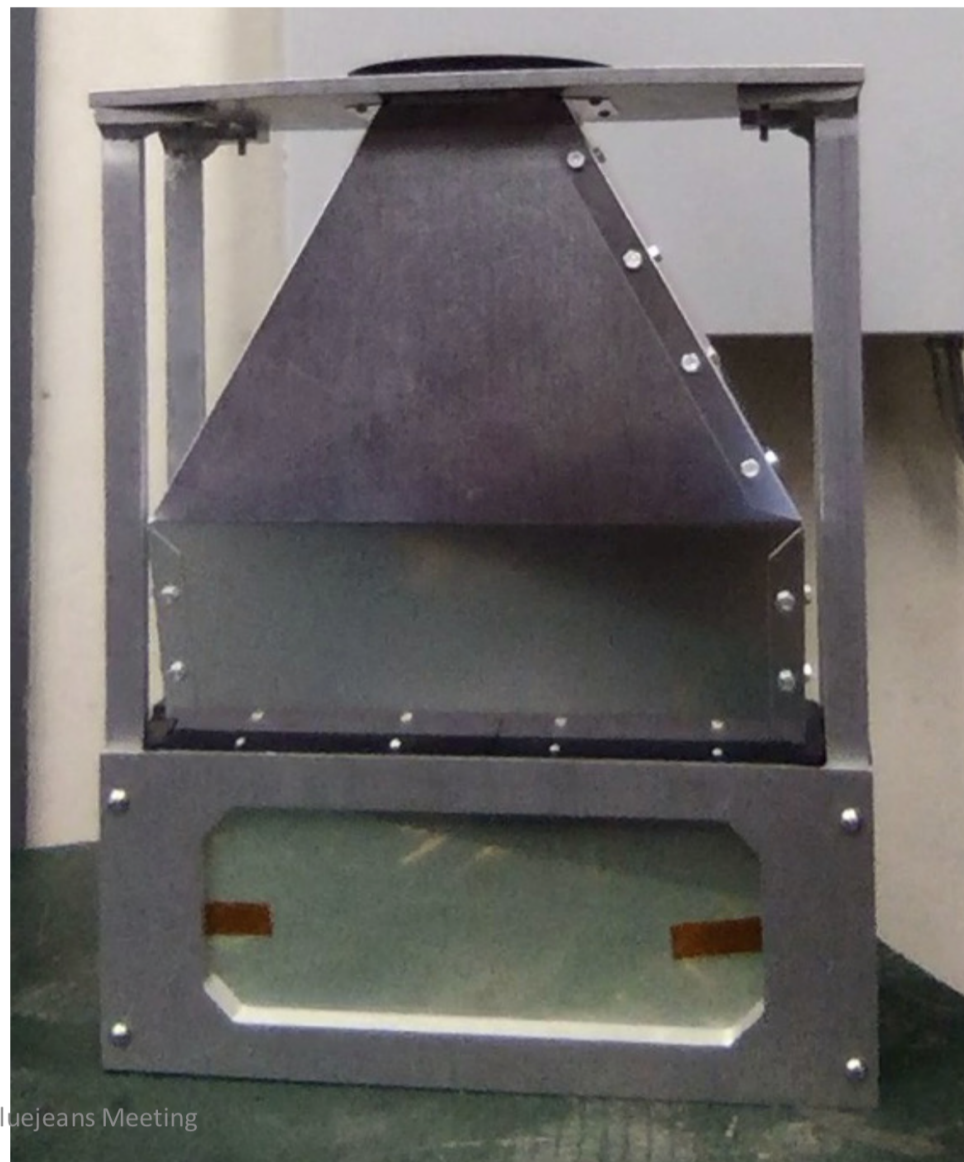

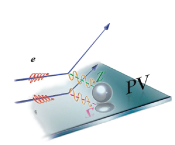

Testbeam and MC benchmarking strategy

- Engineer benchmarking prototype capable of operation with systematically more stack layers added and with no light guide
- Basic strategy outline:
 - First take data with only one piece of quartz
 - Then add the front tungsten plate and take data, then the next layer of tungsten and quartz, then next, then next
 - This will facilitate benchmarking of optical quartz properties and G4's showering process without light guide complication
- Also construct and test full scale prototypes (with same exact stack configuration as benchmarking prototype) and with full light guide; this will be constructed with machined aluminum

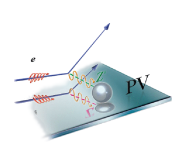

Benchmarking Prototype (1A) Expectations

Benchmark 1A: Single Quartz

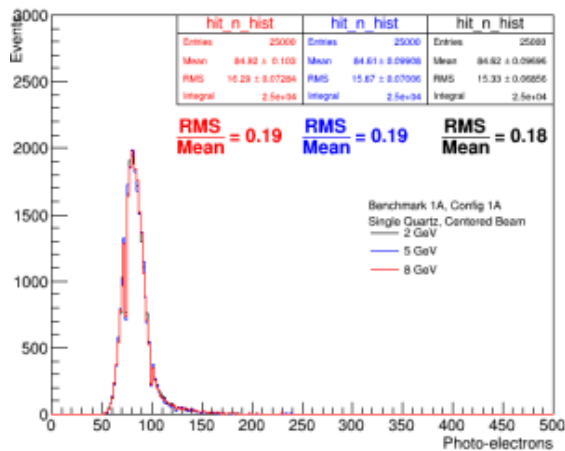

Benchmark 1A: n=1

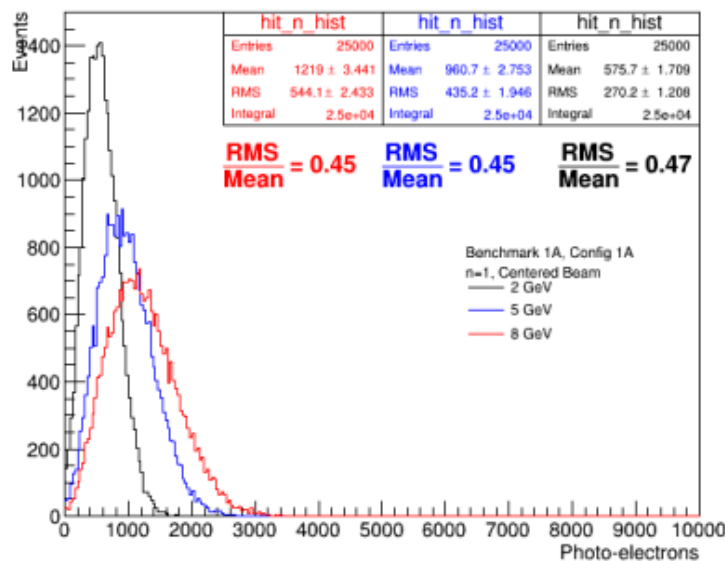

Benchmark 1A: n=2

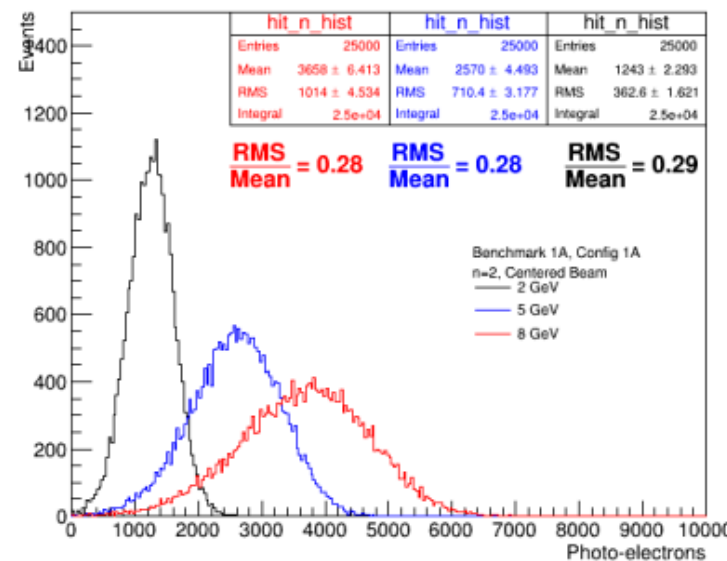

• Benchmarking PE yields are incredibly high for n=1 to 4

• Will use 3" ET PMTs: 9305QKB

Benchmark 1A: n=3

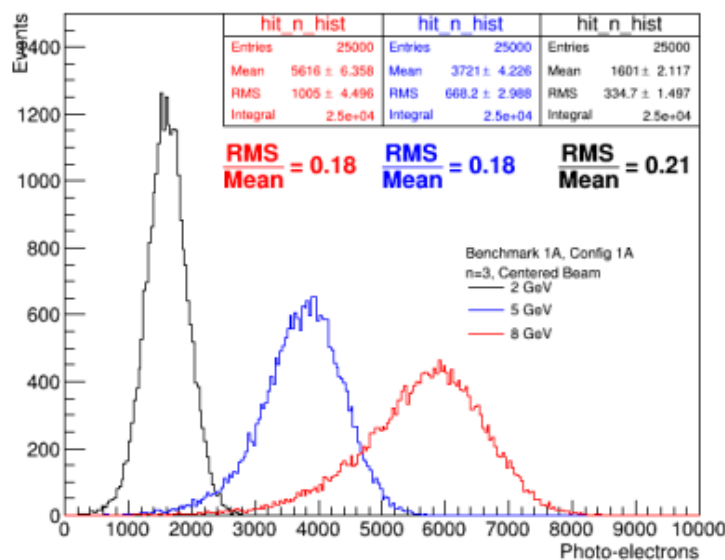

Benchmark 1A: n=4

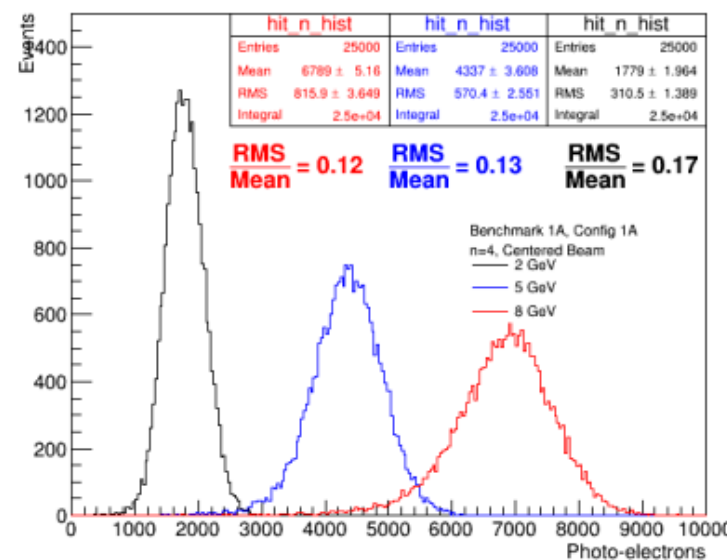

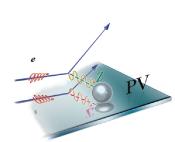

T-577: SLAC Testbeam, Dec 6 – 12, 2018

- Tested ShowerMax full-scale and benchmarking detectors and new ring5 thin detector designs
- Used 3, 5.5 and 8 GeV electrons with multiplicity of a Poisson distribution with $\mu \approx 1$
- Overall beam rate only 5 Hz (parasitic from LCLS beam) with $\sim 1/3$ of those being single e^-

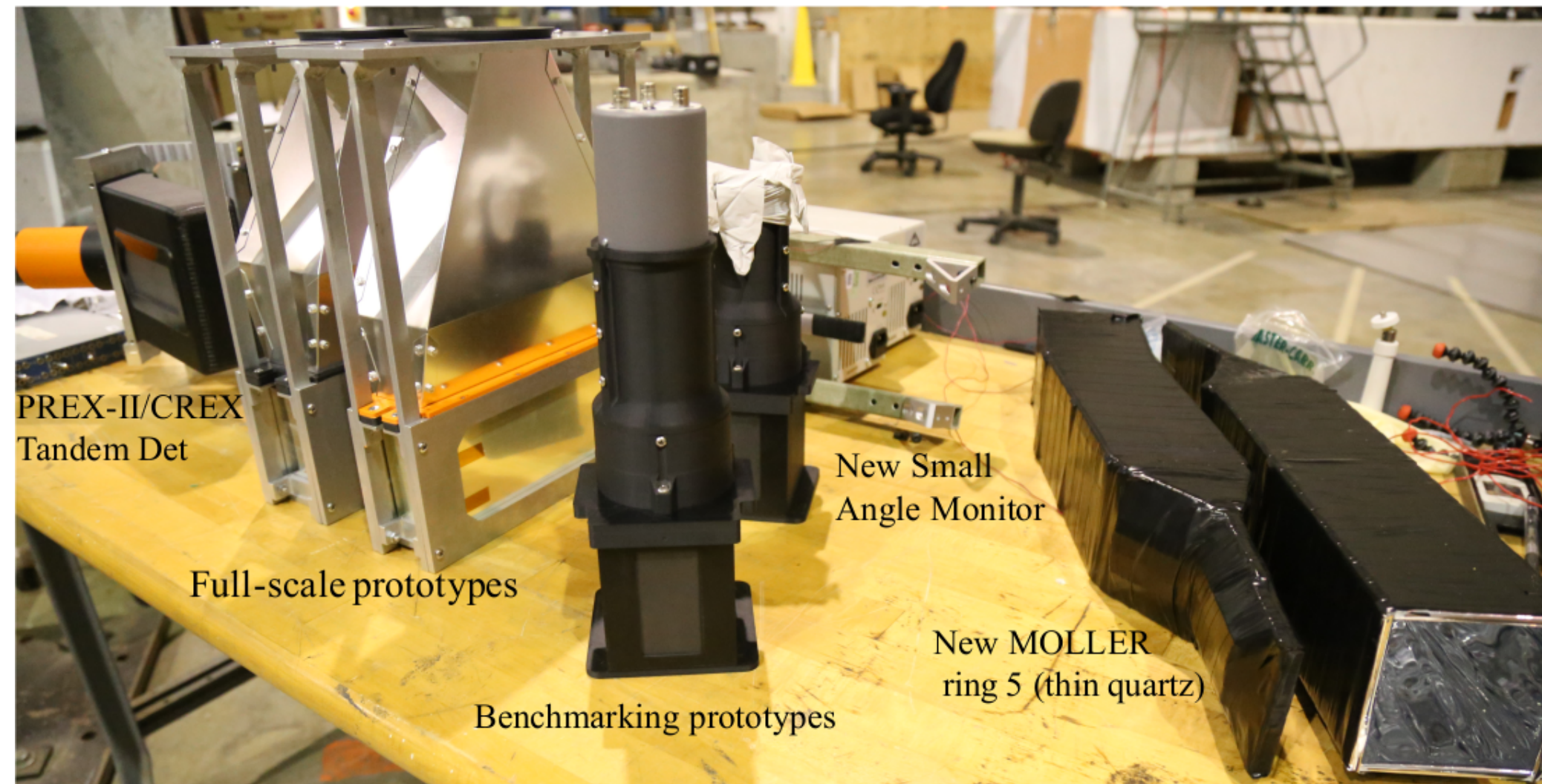

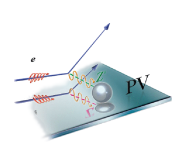

CAD of the SLAC testbeam setup

- Testbeam scheduled for Dec 5 – 10 (we may get more time)
- Setup allows testbeam to cover entire active area of full-scale prototypes

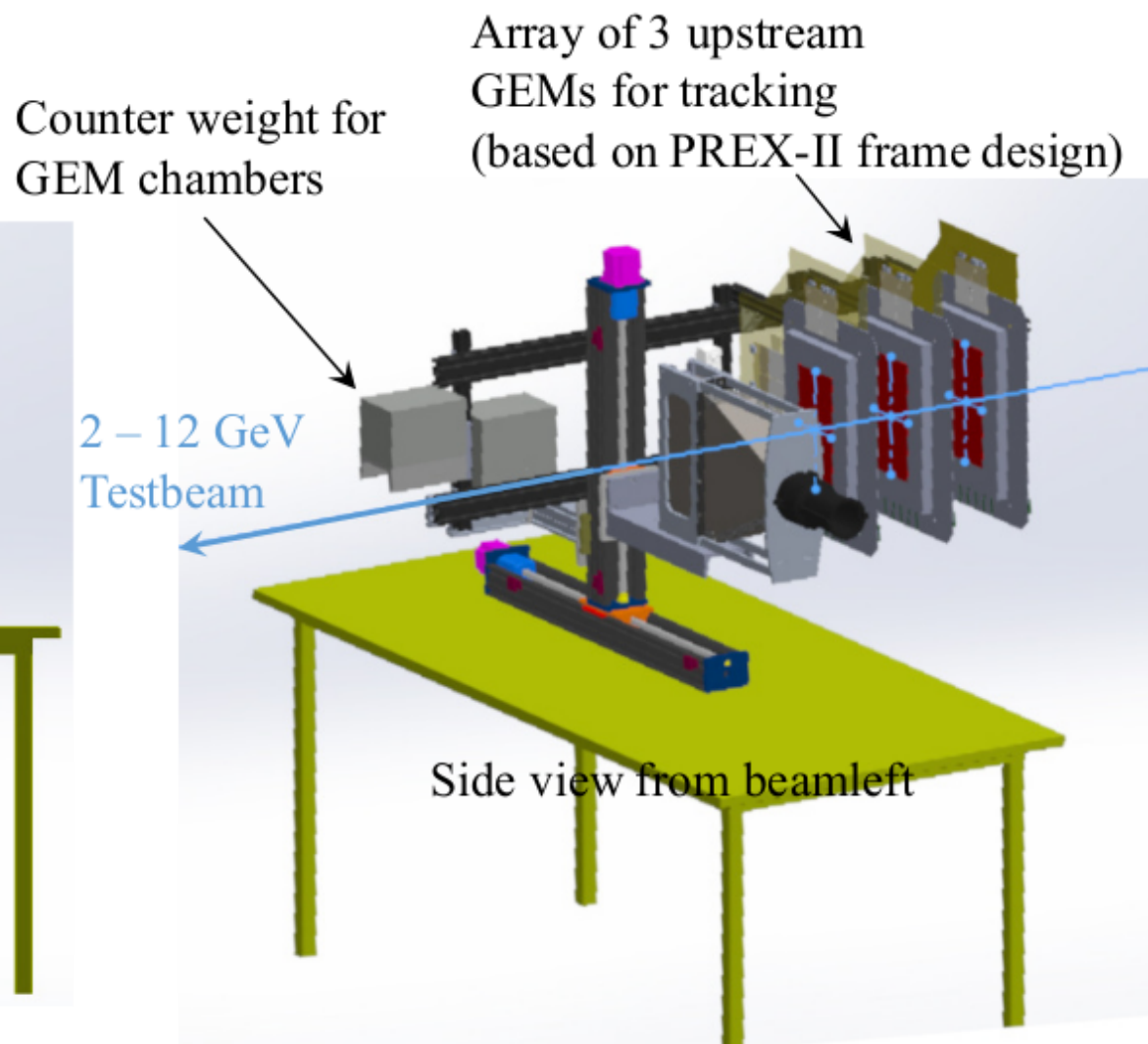
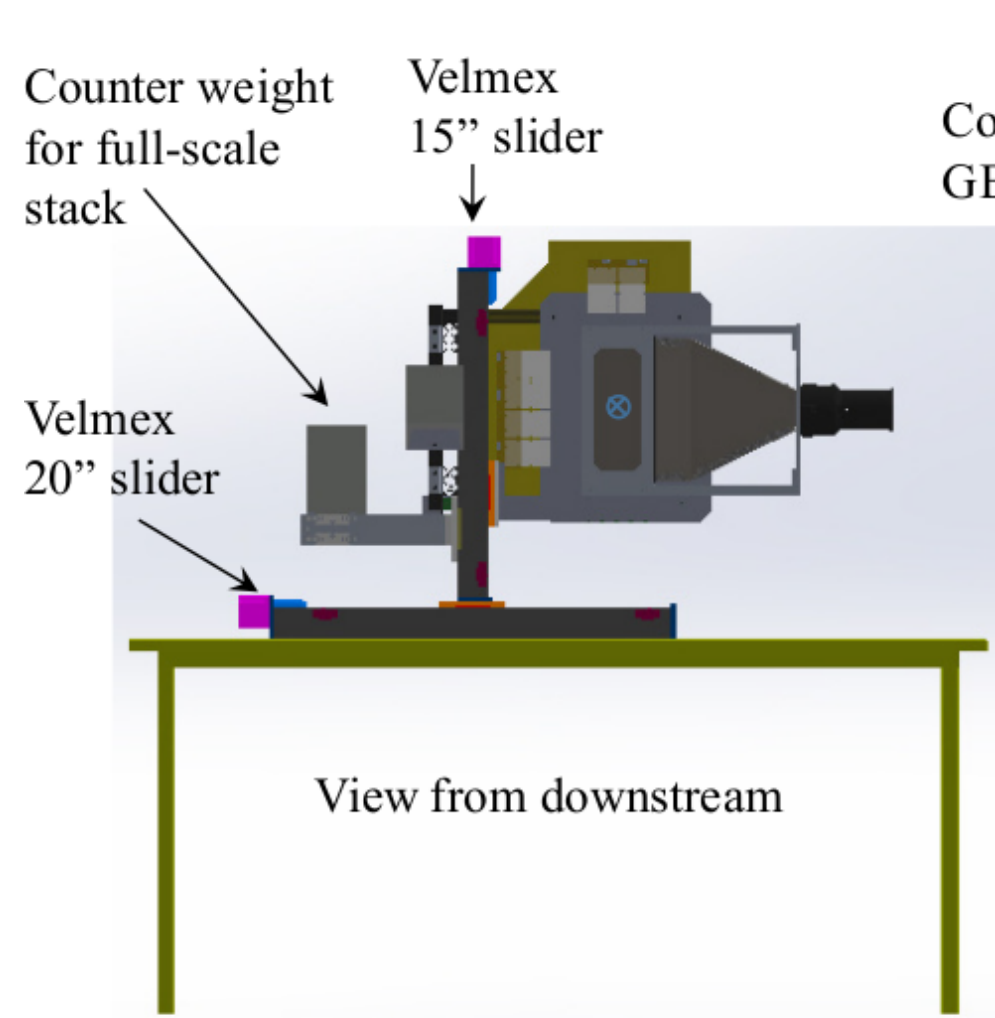

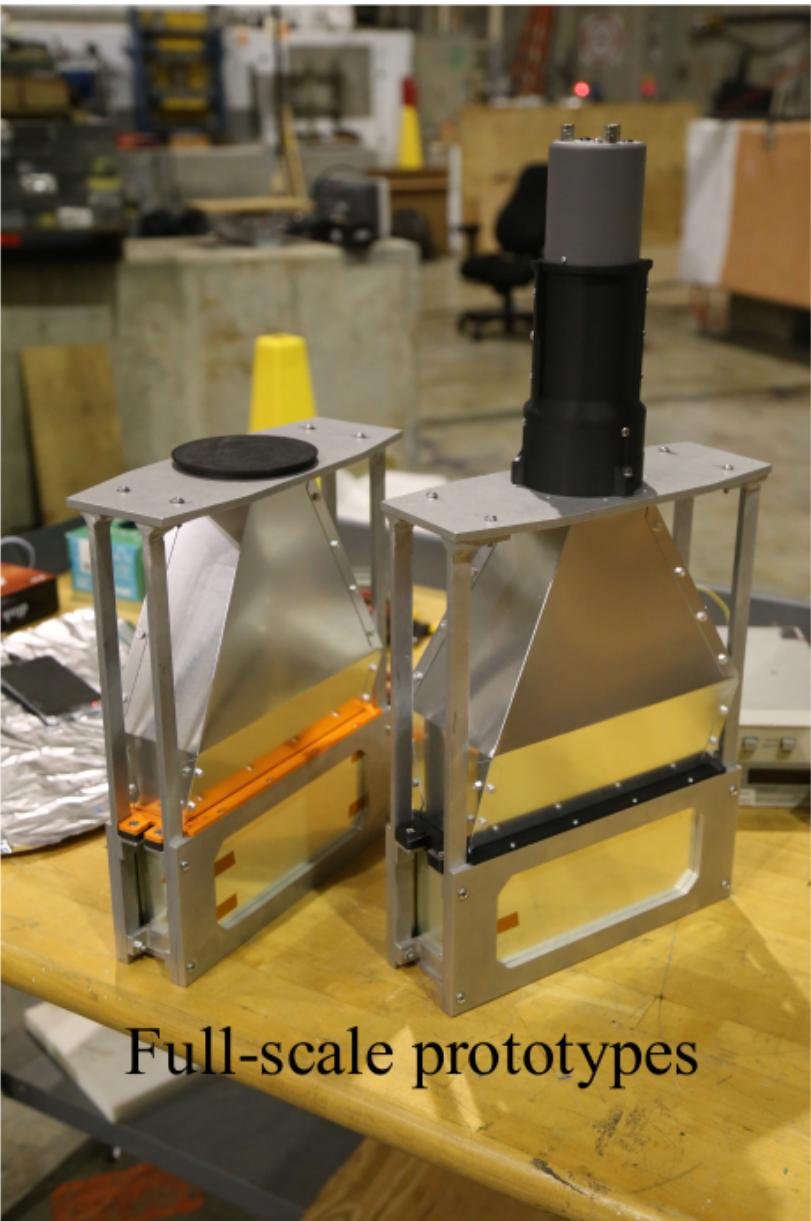
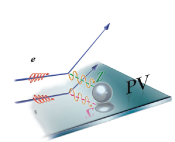

Full-scale prototypes

T-577: SLAC Testbeam Setup for Full-Scale ShowerMax

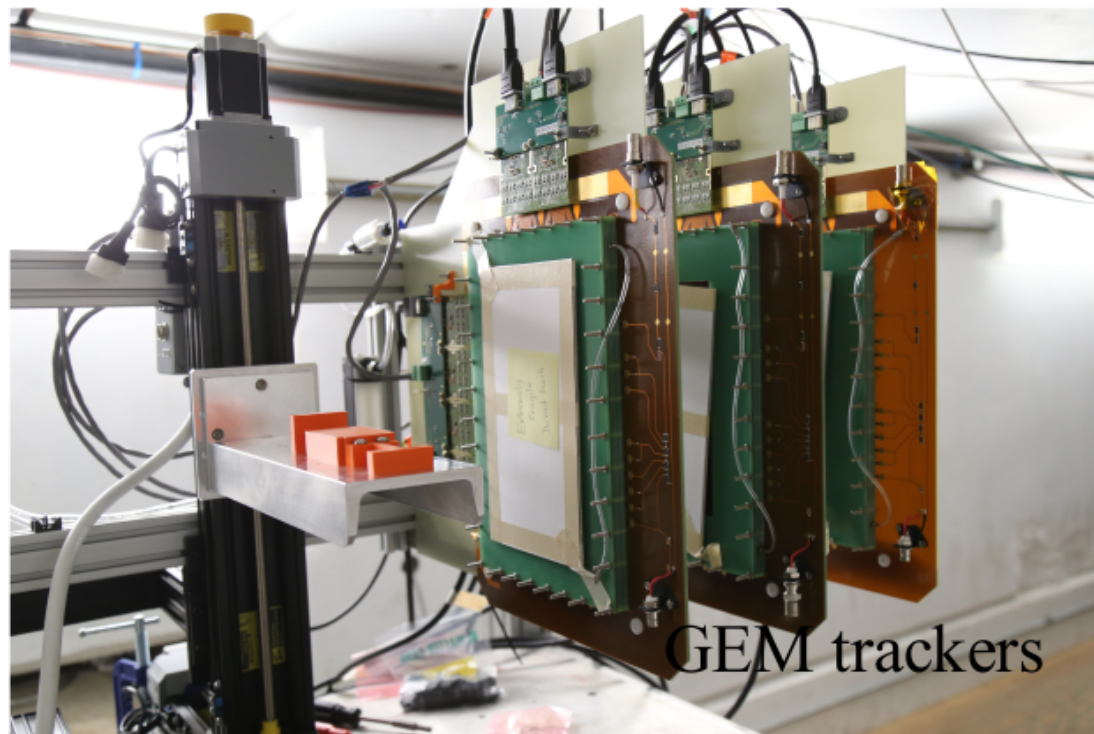
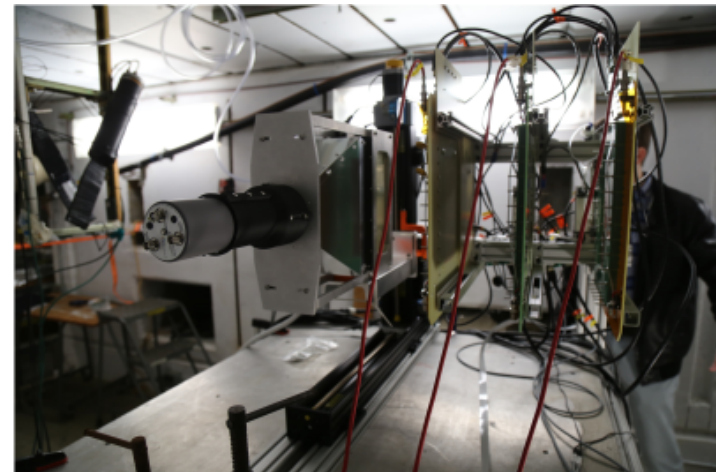

GEM trackers

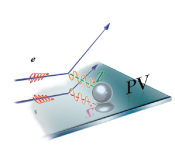

T-577: SLAC Testbeam Setup: Benchmarking ShowerMax

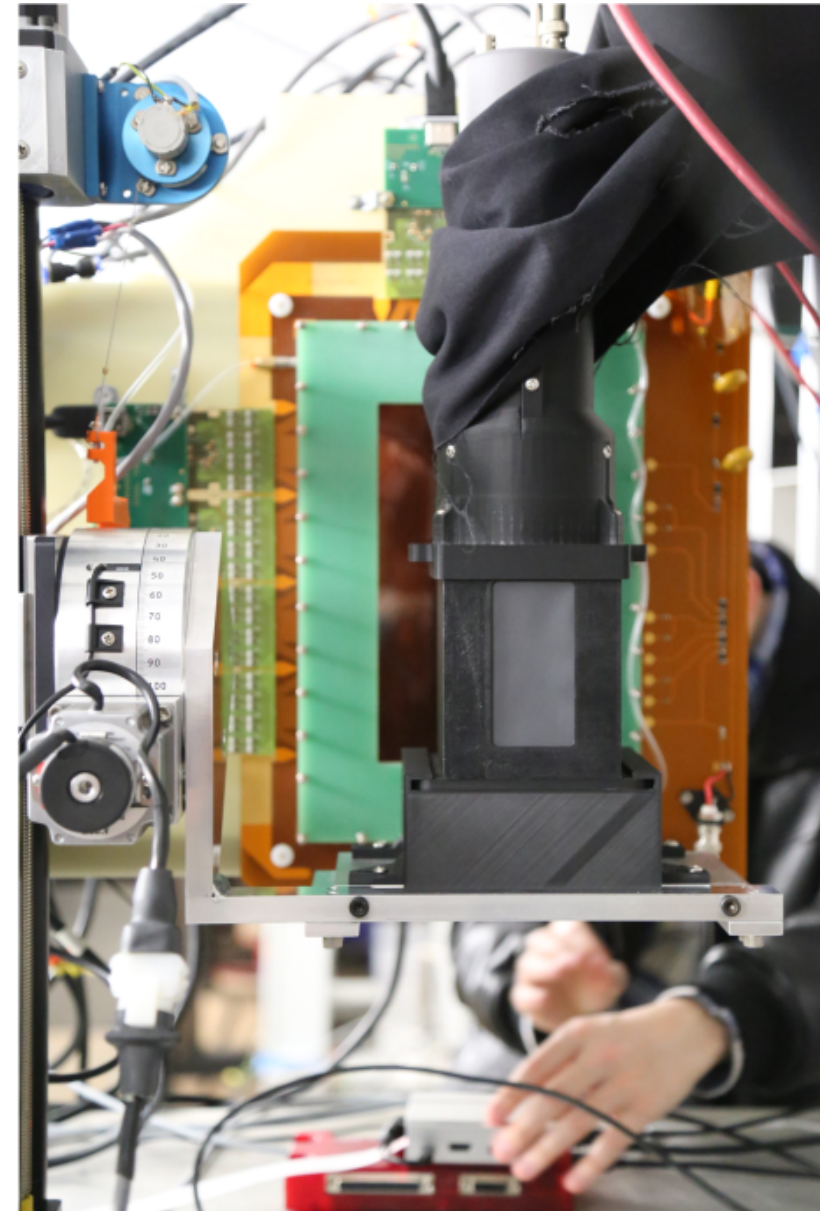

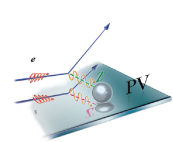

Beam Spot (5.5 GeV): ~ 1 cm by 2 cm

Det 2 XY hits

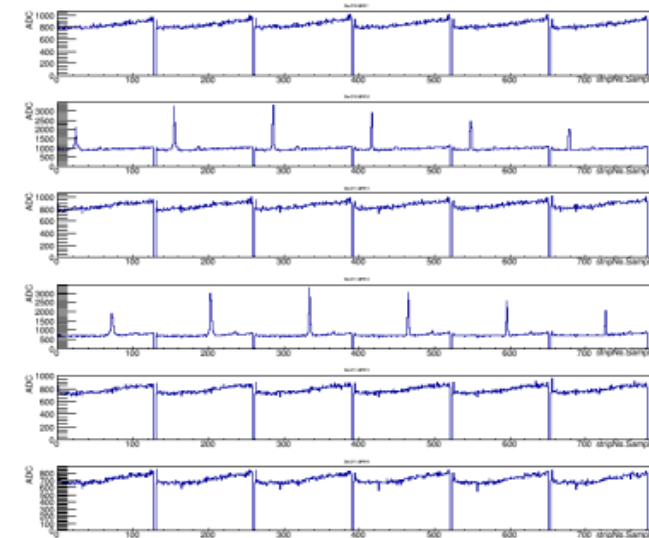
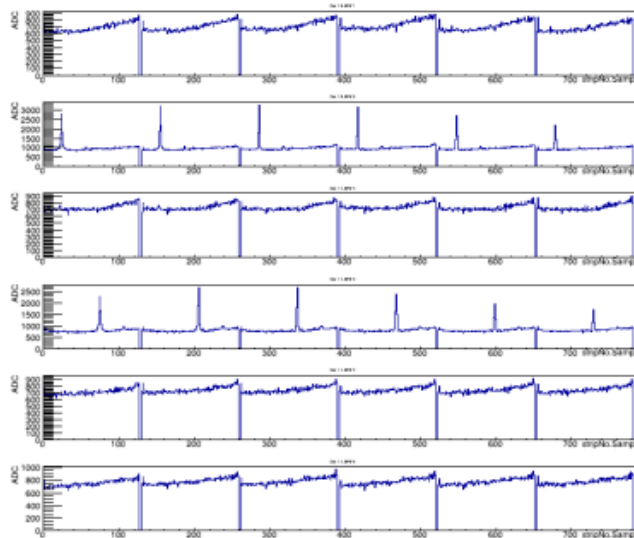
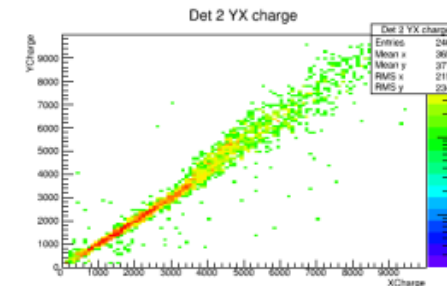
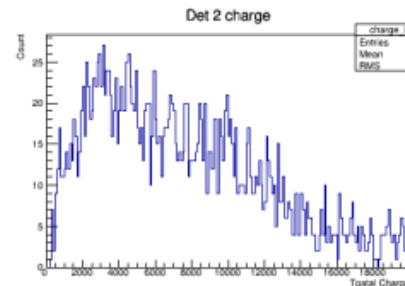
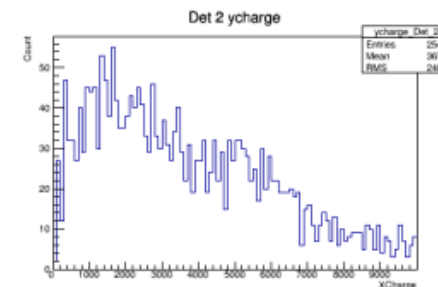
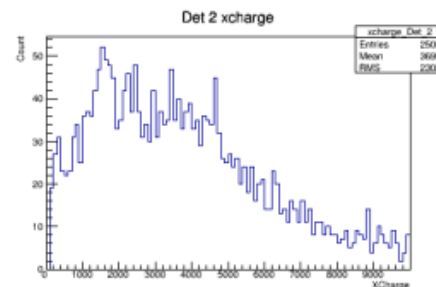
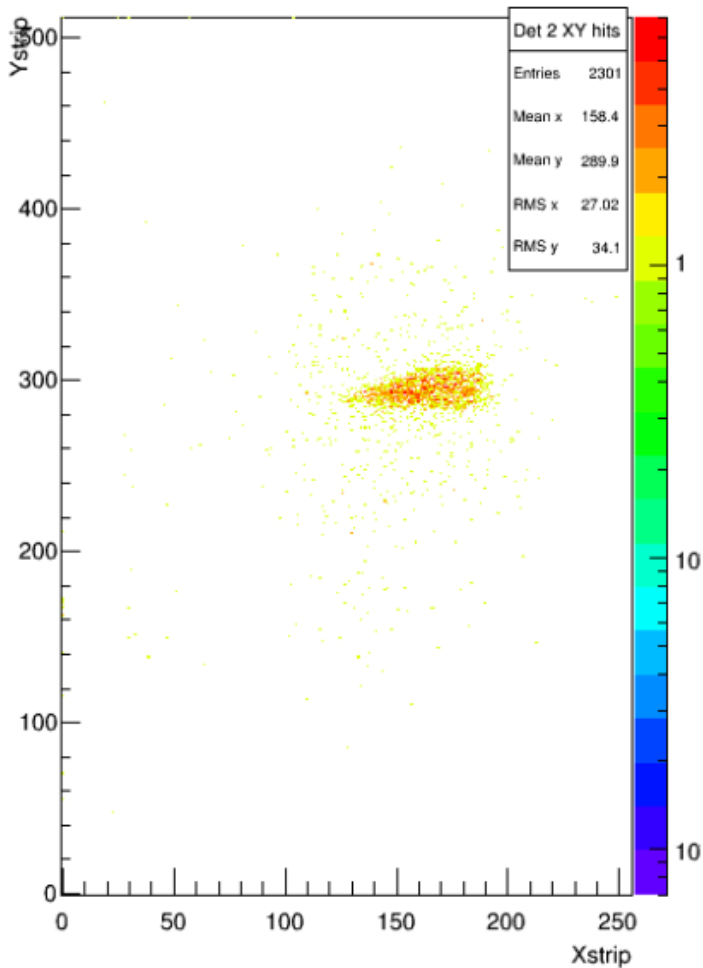

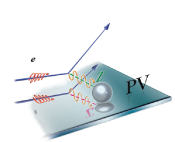

SLAC Testbeam sample data (from PREX Tandem Det) Run 417

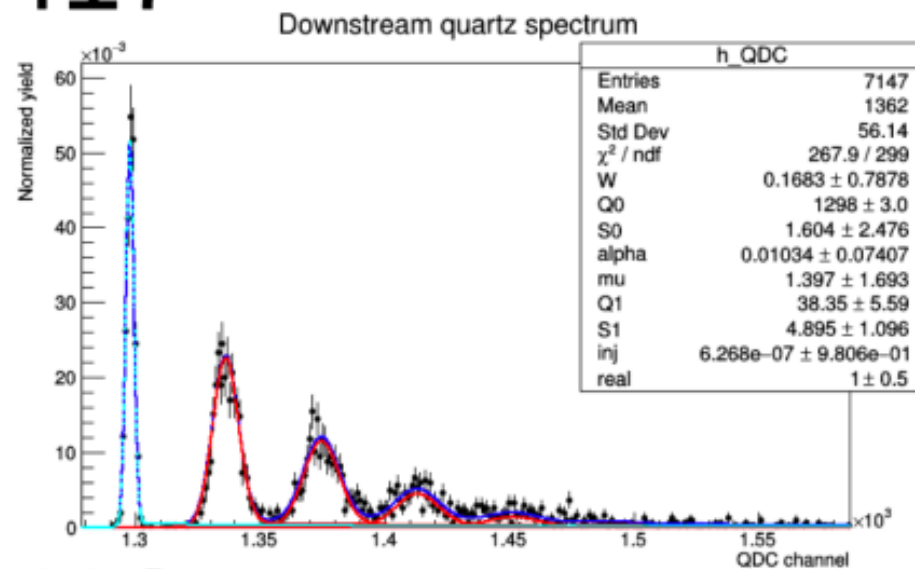
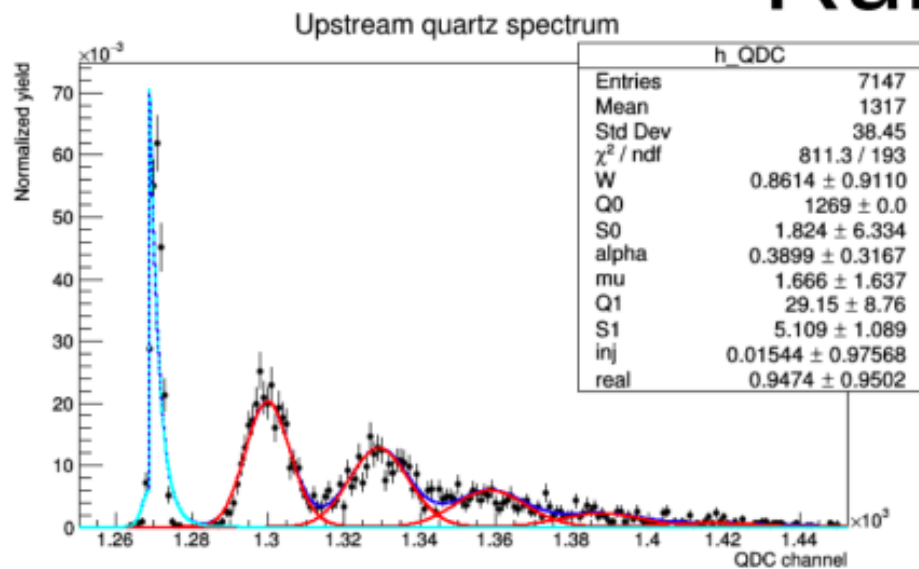

Run 418

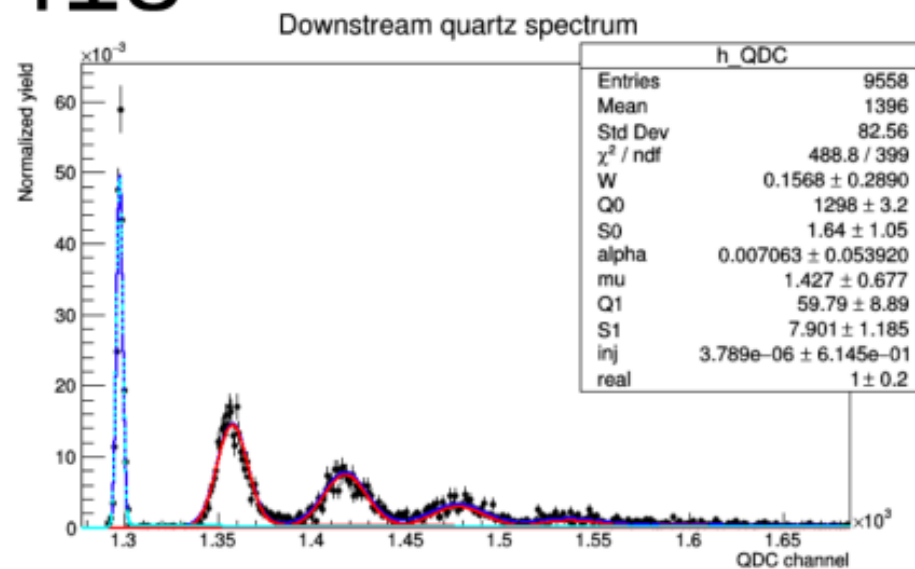
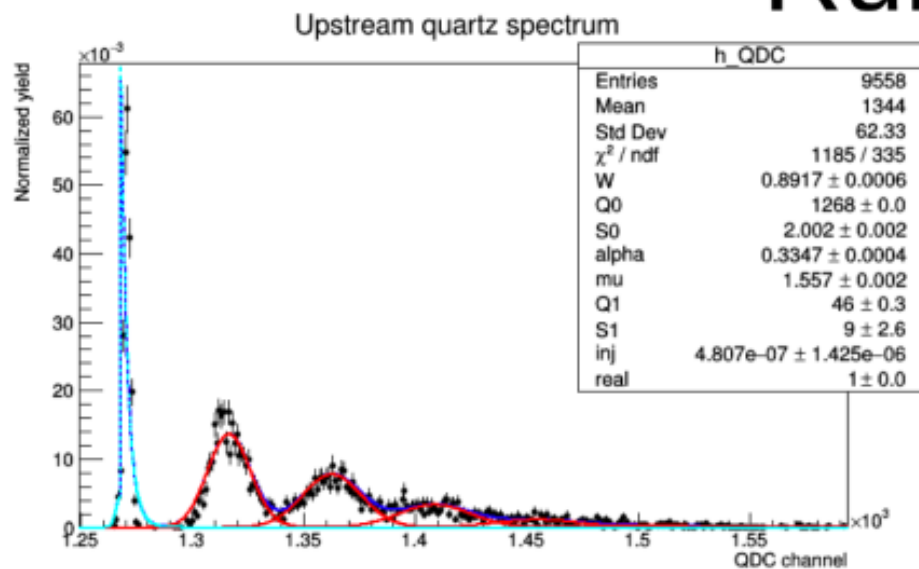

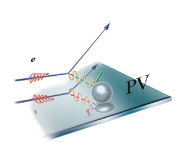

ShowerMax Benchmarking Prototype Testbeam Results (1B response vs. stack layers)

Benchmarking 1B: Compare stacks

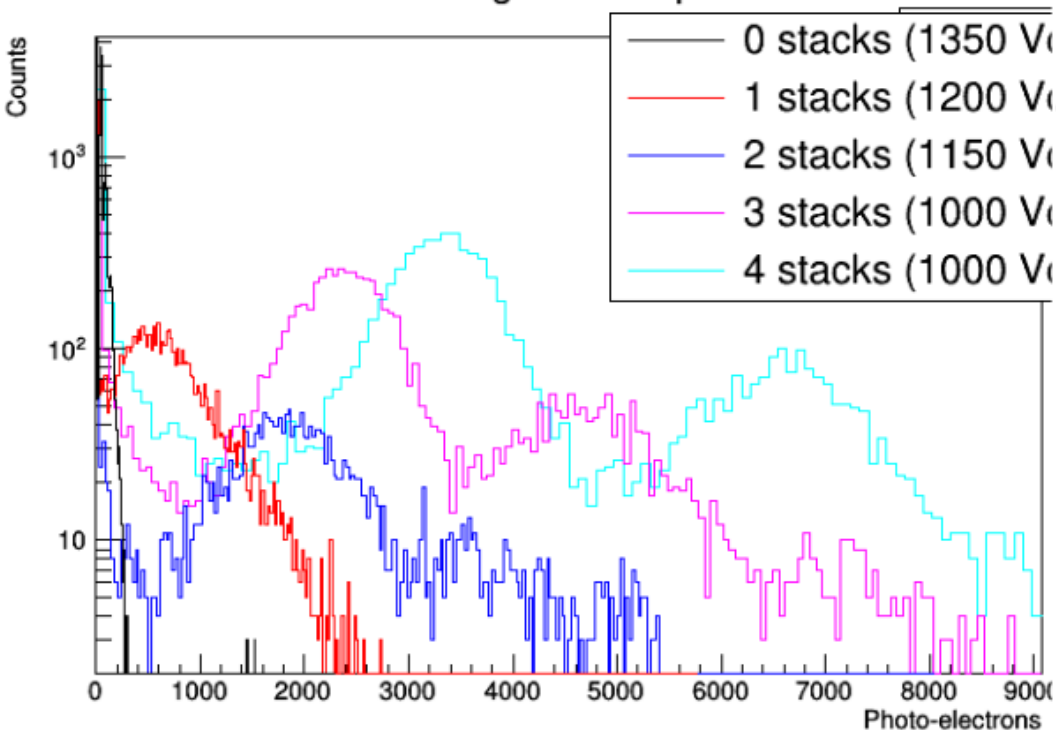

Benchmarking 1B: Compare stacks

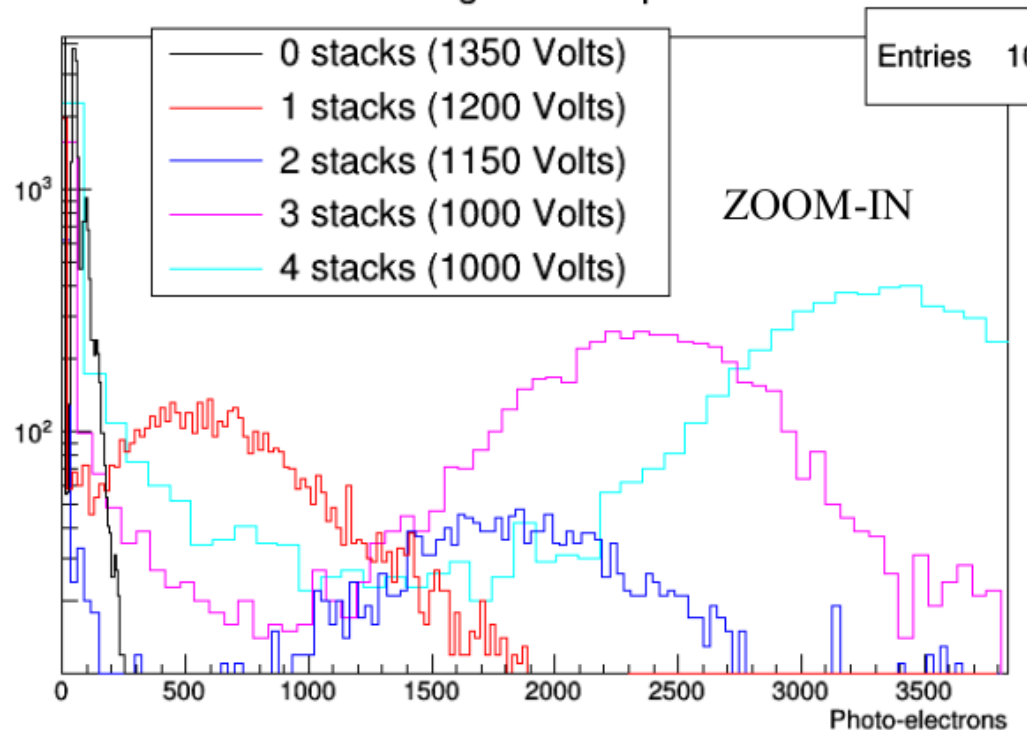

- Results are very reasonable—the means and relative widths behave as expected
- Simulations are underway for comparison and MC tuning/benchmarking

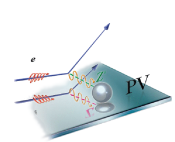

ShowerMax Benchmarking Prototype Testbeam Results (1A and 1B full stack response vs energy)

Benchmarking 1A: Full stack

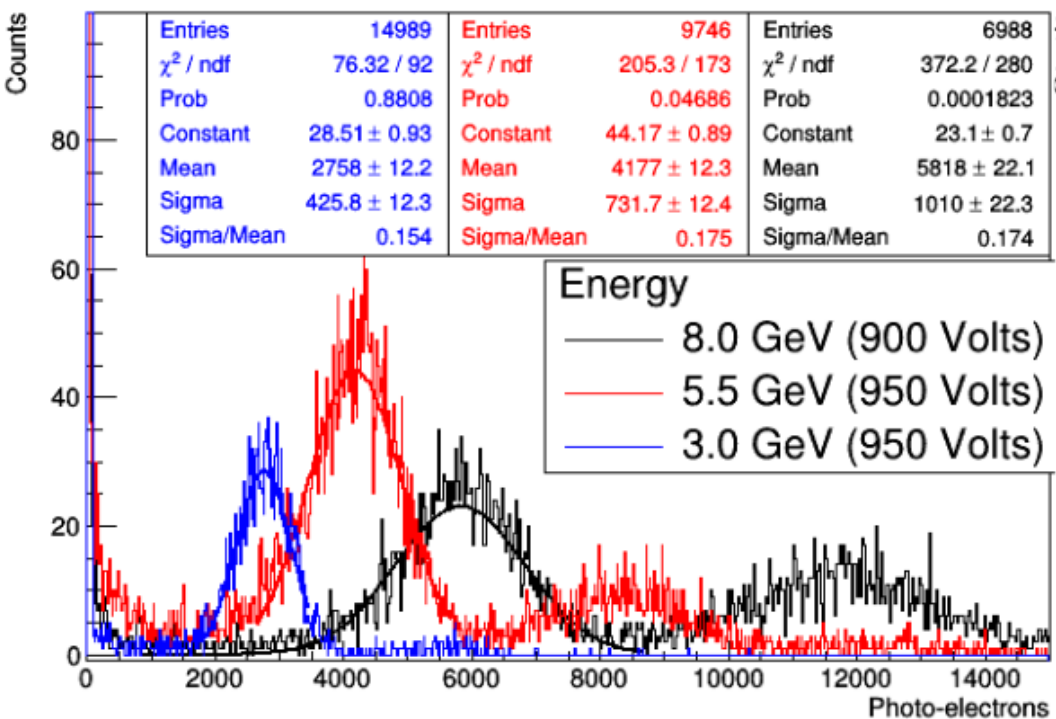

Benchmarking 1B: full stack

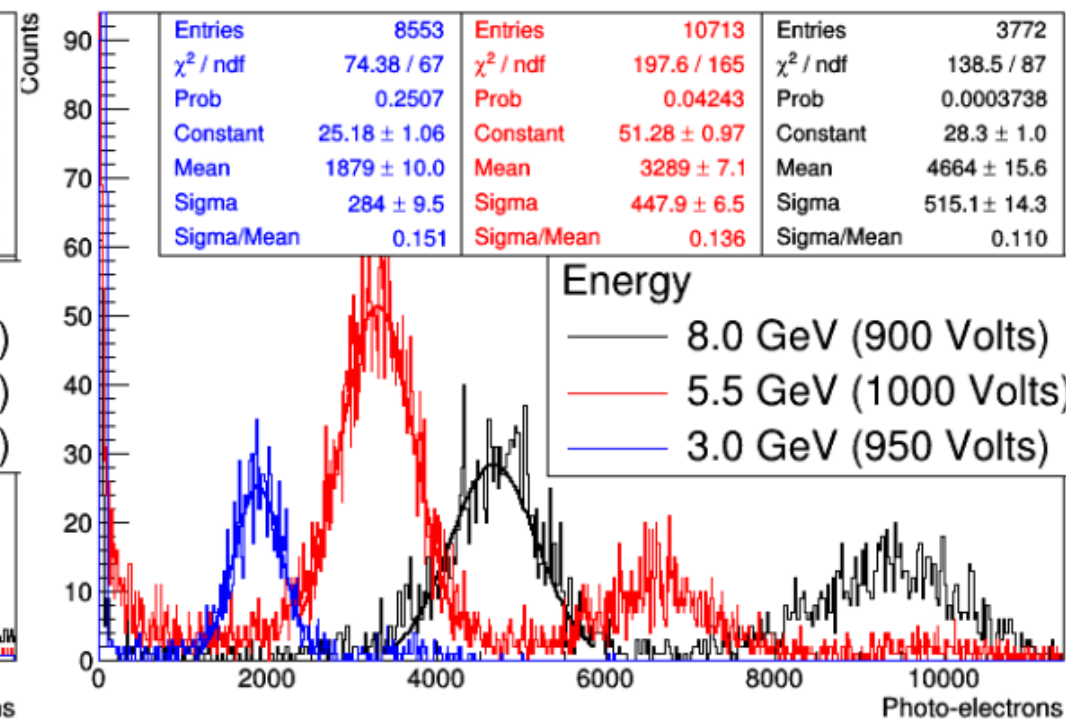

- Comparing these results with previous simulations:
 - For 1A simulation: Mean PEs are ~ 1800 , ~ 4300 , and ~ 6800 for 2, 5, and 8 GeV, respectively
 - For 1A real data: Mean PEs are ~ 2760 , ~ 4200 , and ~ 5800 for 3, 5.5, and 8 GeV, resp.
- Comparisons are promising, new simulations are underway and further refinement of data analysis

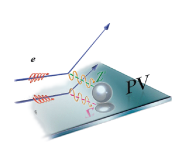

Benchmarking 1A testbeam results compared with simulation (5.5 GeV electron response vs. stack layers)

Photo-Electron Distribution - simulated vs real data

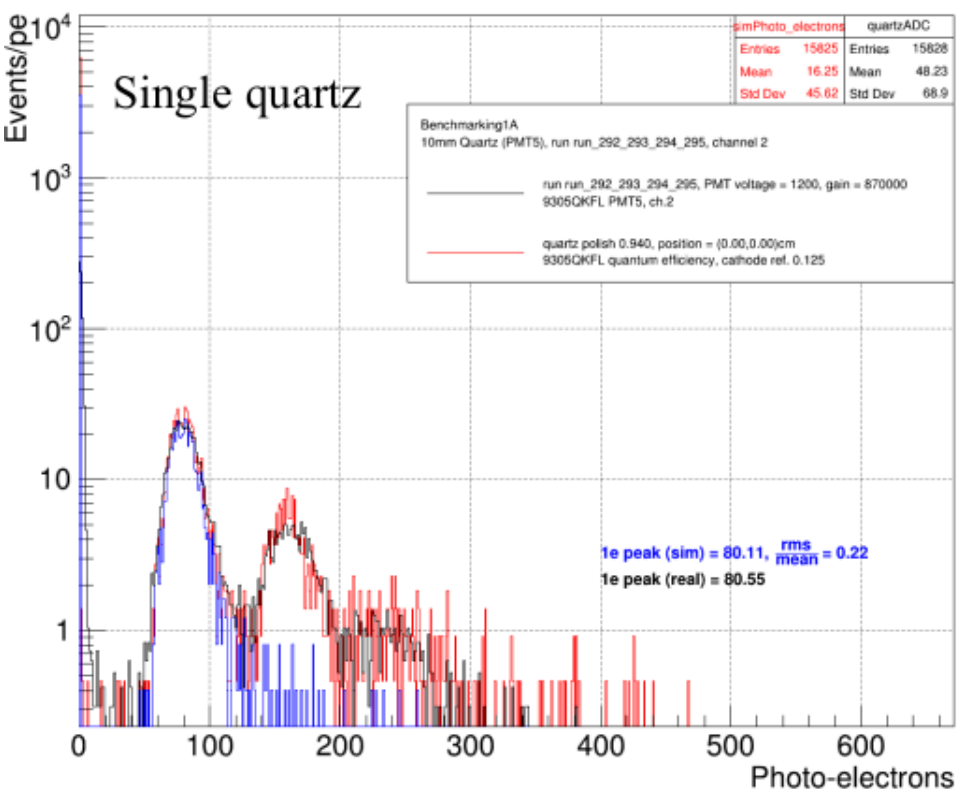
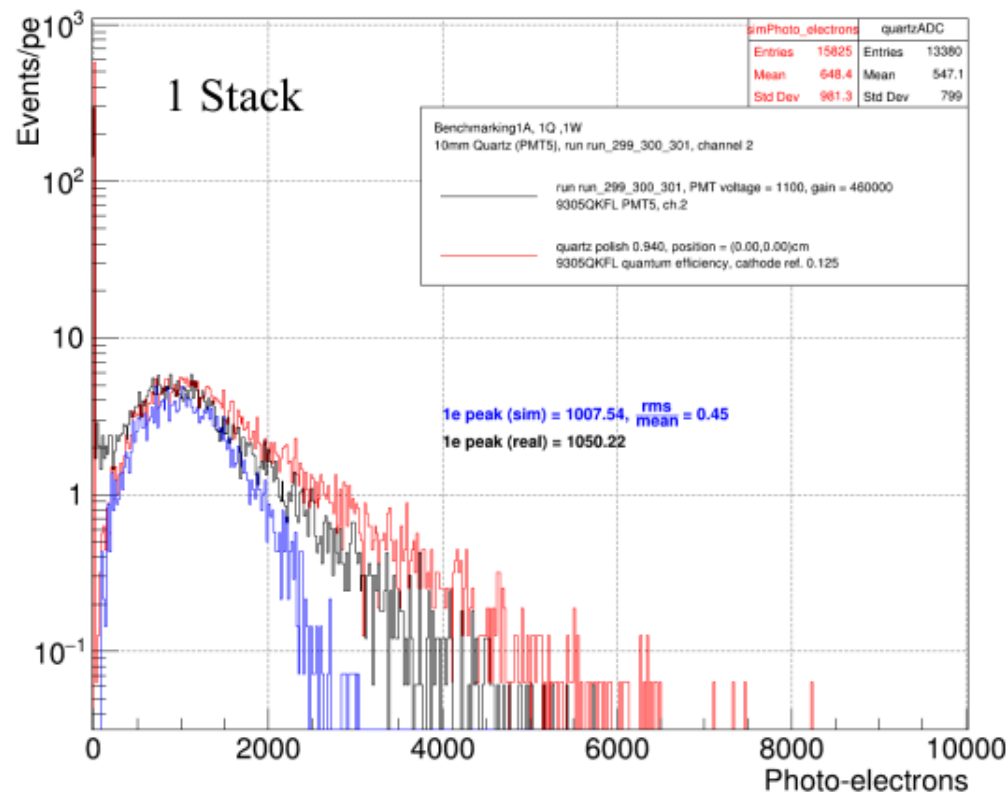
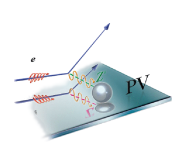

Photo-Electron Distribution - simulated vs real data



- Single quartz data used to benchmark quartz optical polish parameter
- With quartz polish calibrated, simulations performed with successively more stack layers and compared with SLAC data



Benchmarking 1A testbeam results compared with simulation (5.5 GeV electron response vs. stack layers)

Photo-Electron Distribution - simulated vs real data

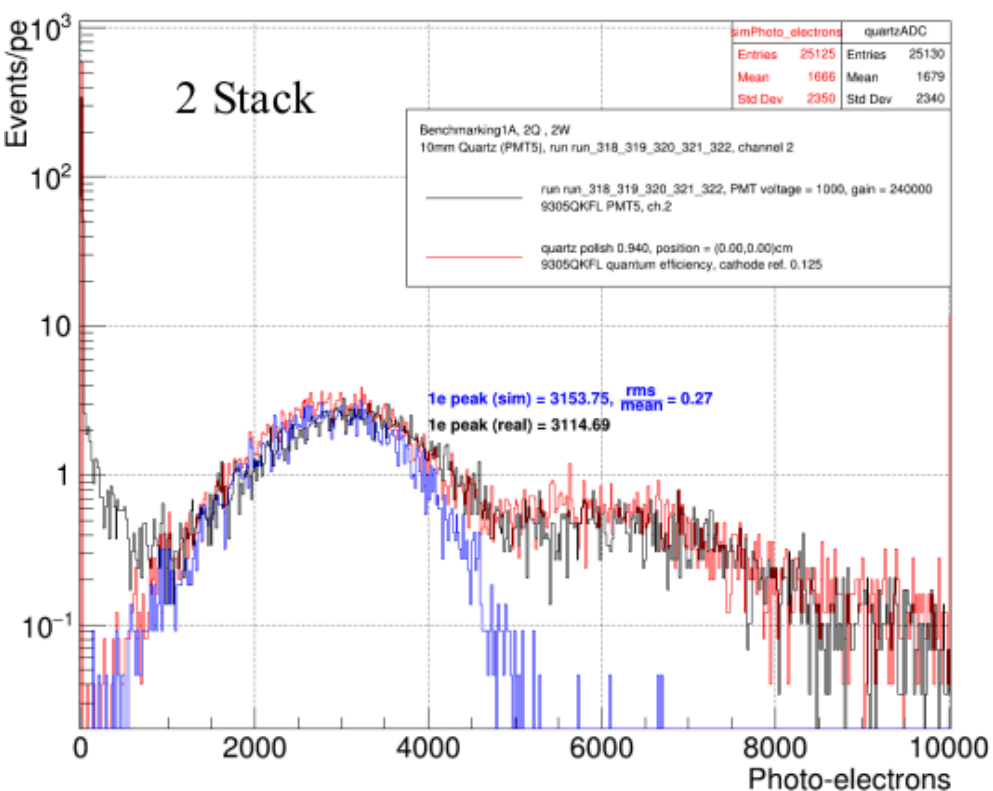
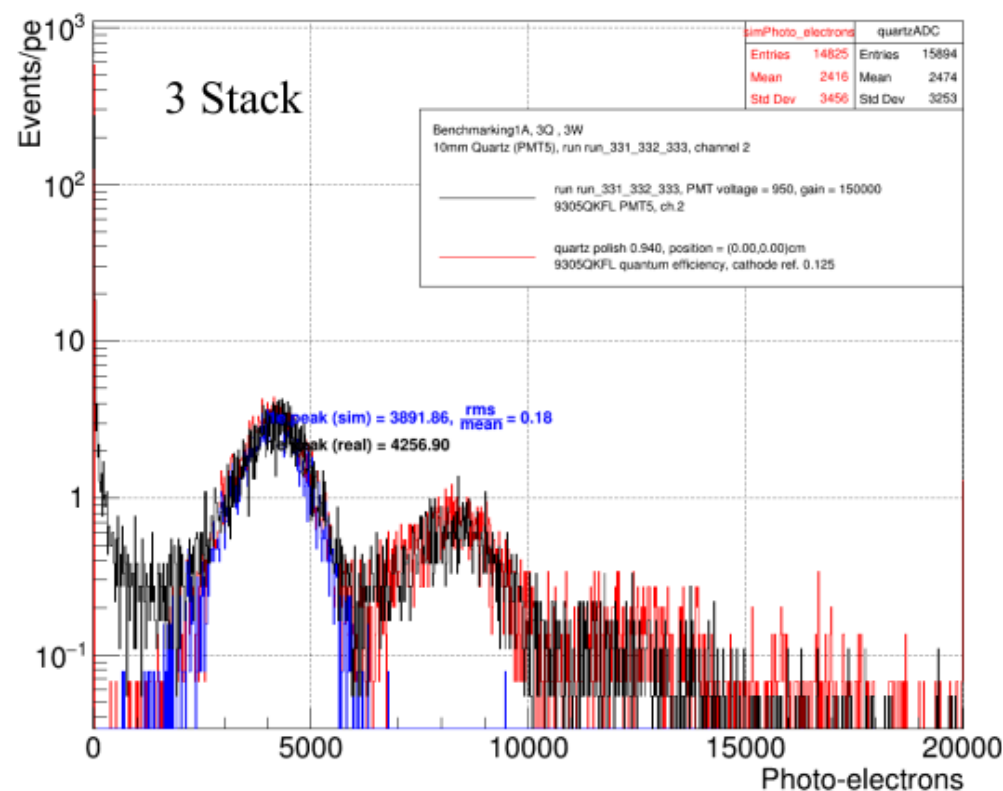
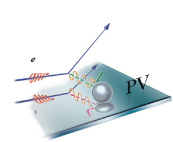

Photo-Electron Distribution - simulated vs real data



- Data and simulation agree well (at 10% level)
- Resolution of single electron photopeak goes from 27% to 18% (simulated)



Benchmarking 1A testbeam results compared with simulation (5.5 GeV electron response vs. stack layers)

Photo-Electron Distribution - simulated vs real data

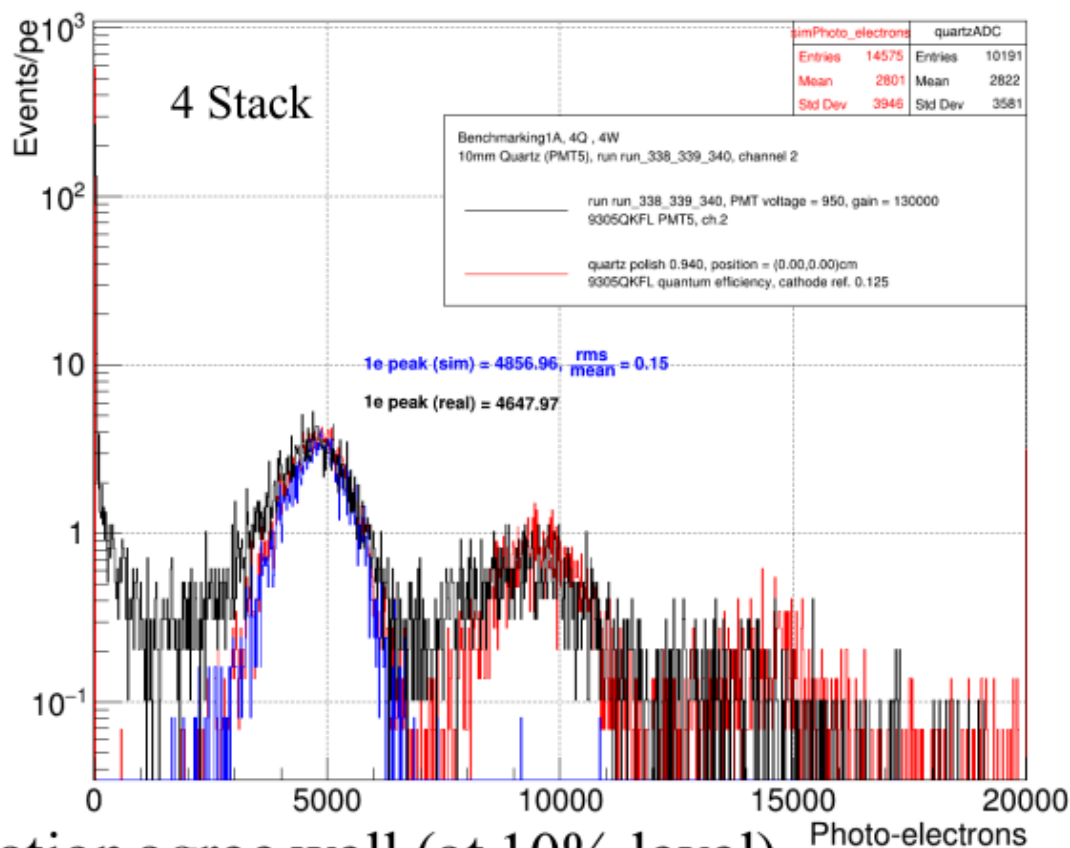

- Data and simulation agree well (at 10% level)
- Resolution of single electron photopeak is 15% (simulated). Analysis of real data resolutions are on-going using GEM tracking data

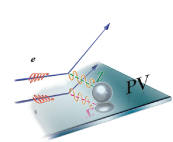

Benchmarking 1A Golden Track, single e⁻ data compared with simulation (5.5 GeV electron response vs. stack layers)

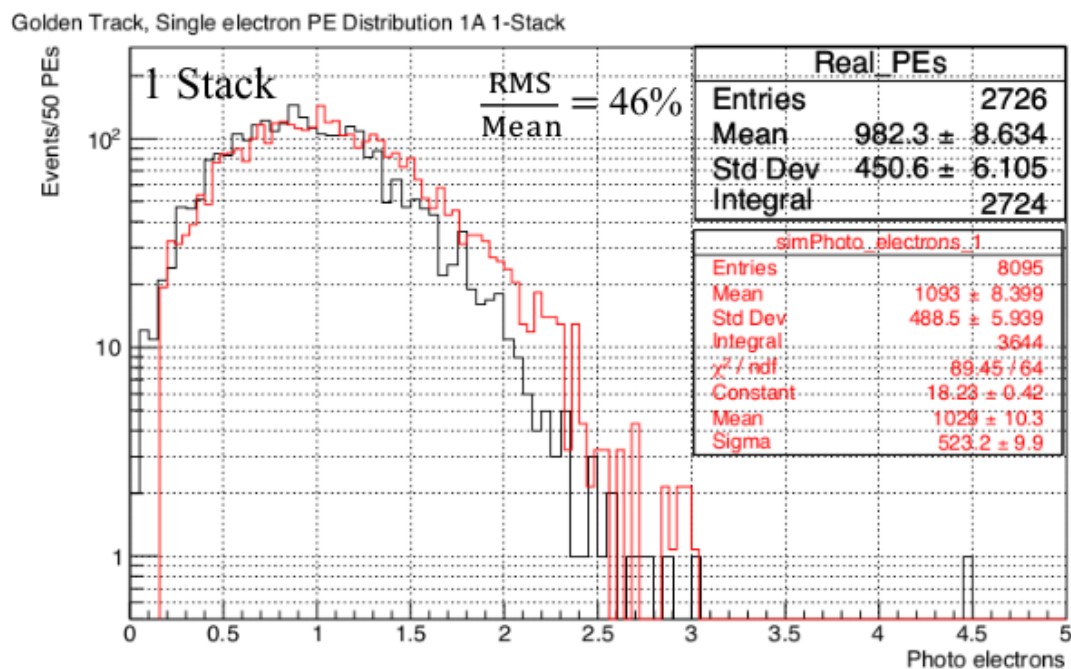
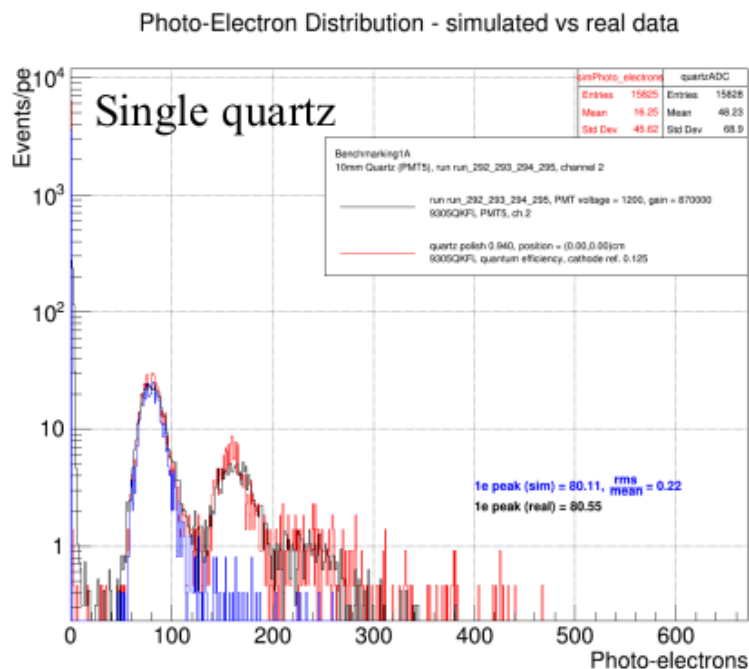

- Note that polish parameter was decreased from 0.98 (PREX) to 0.94 (4% decrease)
- Simulation uses state of the art understanding of optical properties of active material including attenuation and dispersion inside quartz and pmt window, reflectivity at air-pmt window interface & photocathode, and factory QE of photocathode
- Note: All comparisons and polish benchmarking rely on knowing operational pmt gain (5 – 10% uncertainty (as well as QDC charge sensitivity))

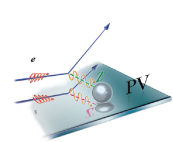

Benchmarking 1A Golden Track, single e⁻ data compared with simulation (5.5 GeV electron response vs. stack layers)

Golden Track, Single Electron PE Distribution 1A 2-Stack

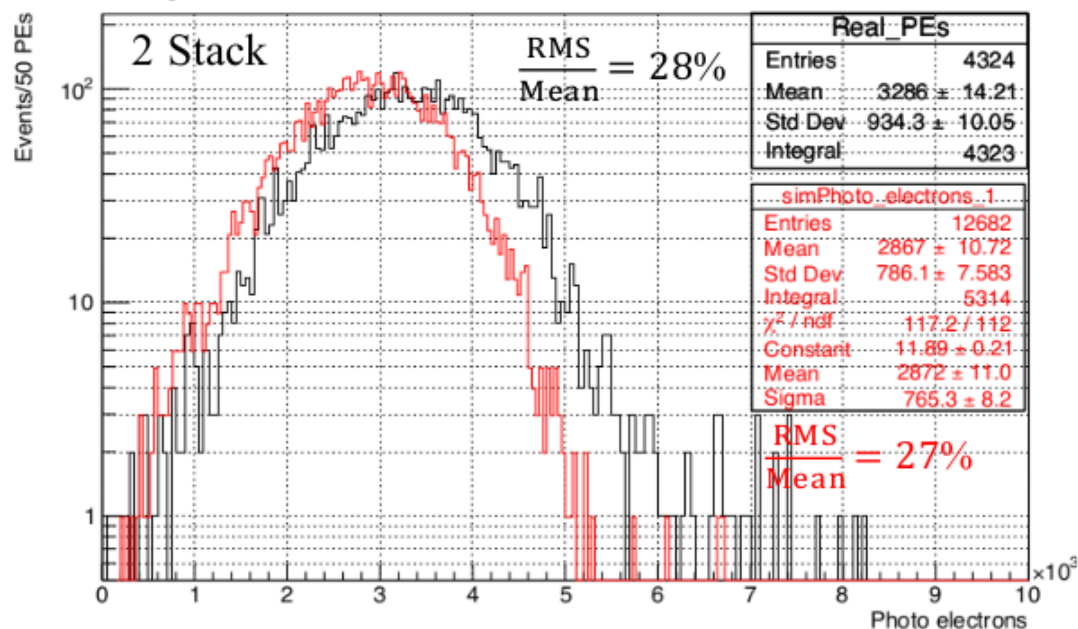

Golden Track, Single Electron PE Distribution 1A 3-Stack

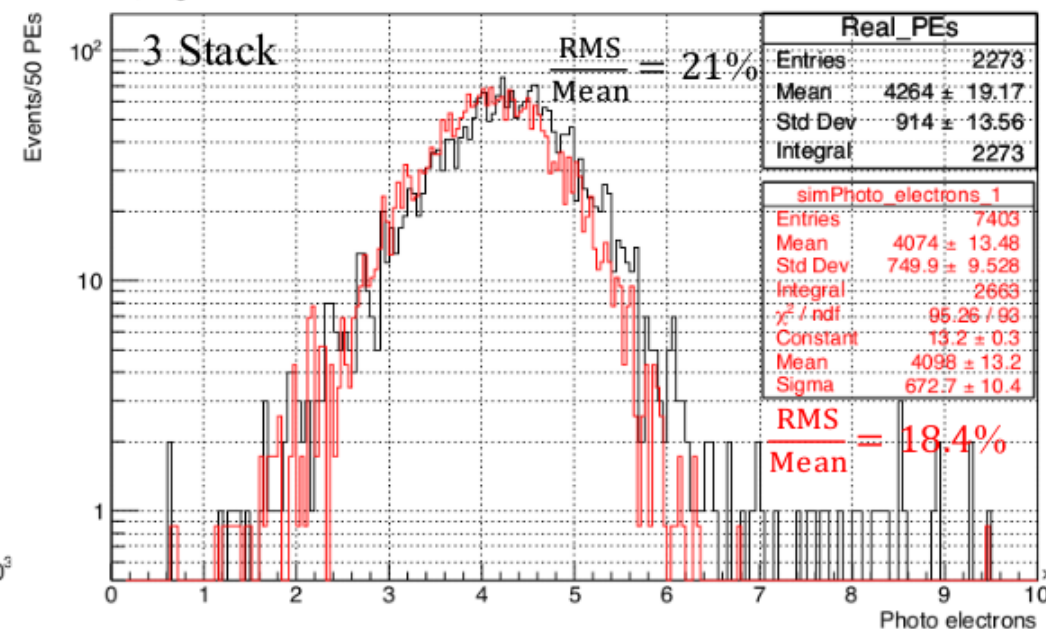

- Data and simulations agree at 10% level
- Data shows larger high-light tails indicating potential mis-identified single e⁻ tracks
- Resolutions get steadily better and agree well with simulated distributions
--This tells us there was good alignment and minimal lateral shower leakage

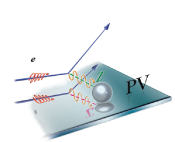

Summary and future work

- Showermax baseline prototypes constructed and tested
 - Analyses of testbeam data still ongoing but converging fast
 - Preliminary results for benchmarking prototypes in good agreement with simulations
 - Full-scale results and uniformity scans still in progress
- First results for full-scale tests show significant difference between data and sims–PE yields $\sim 2.5x$ lower than expected; likely culprit is light guide but could also include broken TIR–due to excessive pressure on Kapton quartz wrapping
- Shower-max detector design and cost is firm: possible cost reductions – use 90/10 W/Cu alloy, thinner quartz bars (marginal saving), PMTs are already one of least expensive options

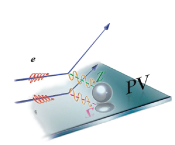

Linearity Test Box And Integrating DAQ

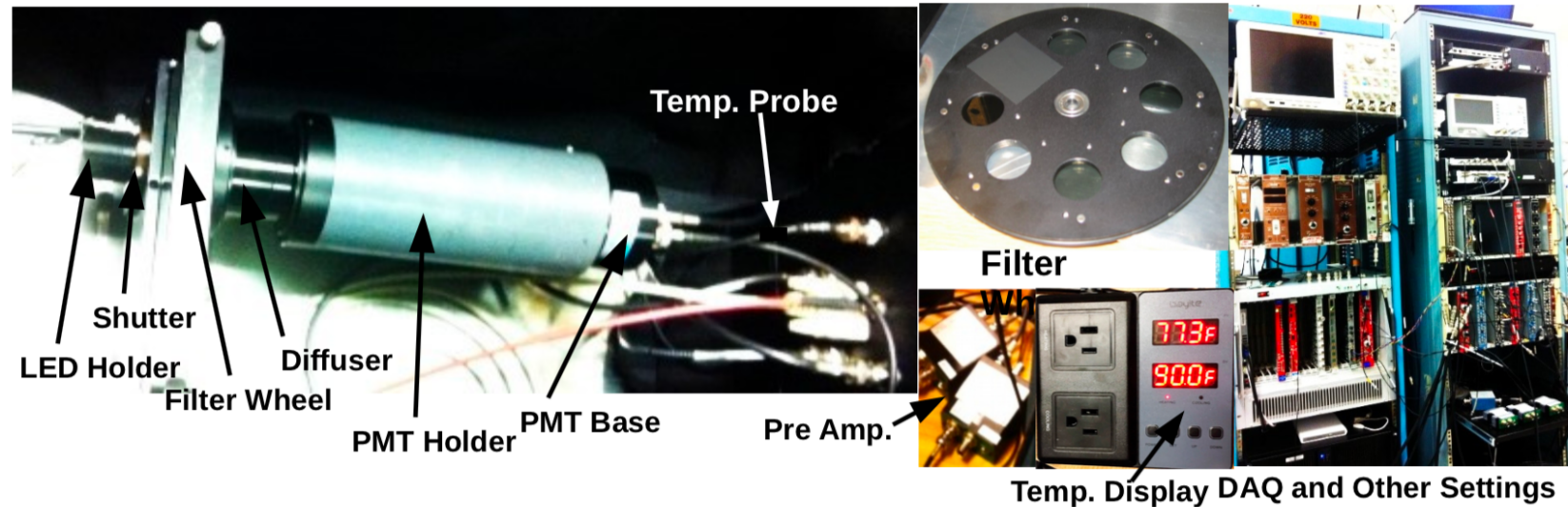

- LED Holder → holds two LEDs, each with 2 mm diameter collimation
- Electronic Shutter → has now been connected with a relay to turn it “ON” and “OFF” automatically at any interval with computer script
- Filter Wheel → Computer Controlled Edmund Optics’ Absorptive ND filters (400-700 nm) with 8 (100, 79, 63, 50, 40, 25, 10, 1)% transmission settings (~randomly ordered)
- Filter Wheel is now controlled automatically using a shell script
- UV Diffuser → Edmund Optics’ ground fused silica
- PMT Holder → 2” PMT with modified base for improved linearity
- Different pre-Amp settings with different resistances and offsets tested (MAIN, LUMI, KDPA, and SNS)

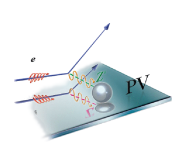

Summary for PMT#4

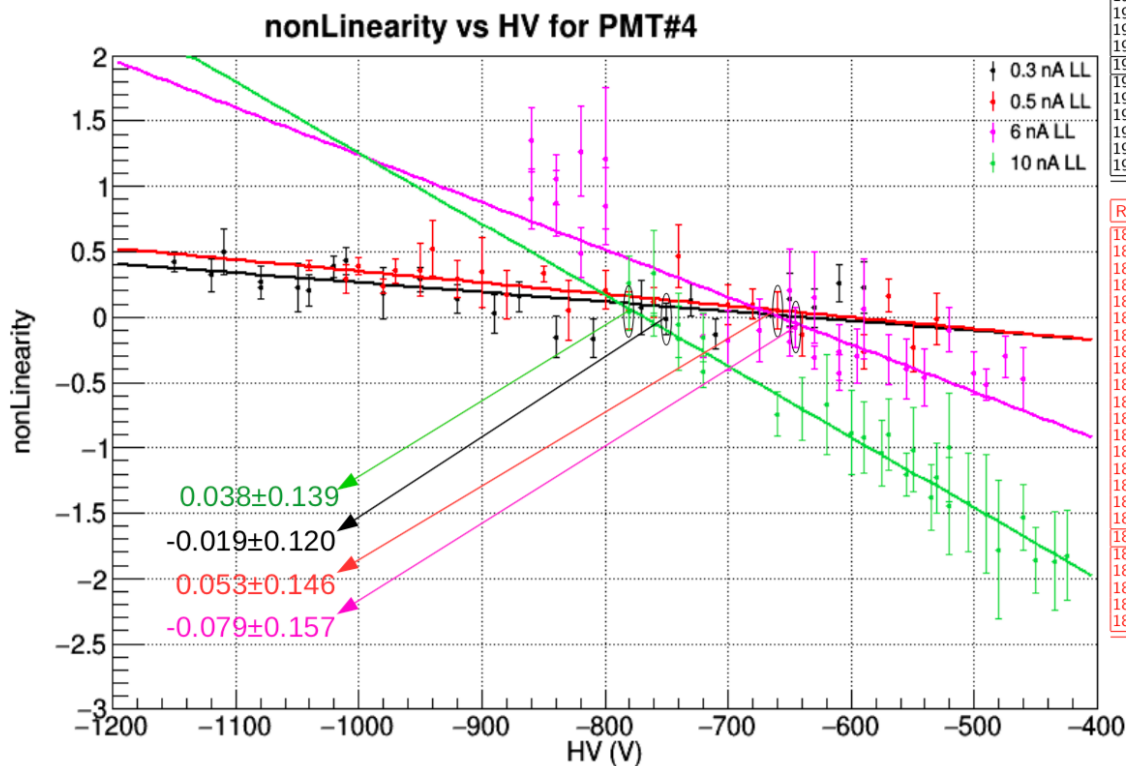

LL = 0.3 nA						LL = 6.0 nA					
Run	HV	PreAmp	non-Lin	Error	$\chi^2/6df$	Run	HV	PreAmp	non-Lin	Error	$\chi^2/6df$
1896	-1150	0.5	0.426	0.075	2.420	1843	-860	0.1	0.904	0.227	16.77
1897	-1120	0.5	0.320	0.123	5.564	1844	-840	0.1	0.869	0.251	25.18
1898	-1080	0.5	0.228	0.093	2.871	1845	-820	0.1	1.269	0.346	26.10
1899	-1040	0.5	0.200	0.120	5.120	1846	-800	0.1	0.848	0.295	29.19
1905	-1110	0.6	0.502	0.172	7.533	1847	-860	0.1	1.355	0.247	15.99
1906	-1080	0.6	0.268	0.125	8.046	1848	-840	0.1	1.054	0.194	14.76
1907	-1050	0.6	0.227	0.186	8.355	1849	-820	0.1	0.492	0.194	17.84
1908	-1020	0.6	0.389	0.083	2.008	1850	-800	0.1	1.211	0.541	98.22
1901	-1010	1.0	0.431	0.102	3.712	1834	-720	0.3	-0.148	0.163	9.668
1902	-980	1.0	0.182	0.193	16.58	1835	-700	0.3	-0.179	0.229	9.338
1903	-950	1.0	0.287	0.091	2.936	1837	-675	0.3	-0.104	0.242	13.89
1904	-920	1.0	0.137	0.112	3.769	1838	-650	0.3	0.205	0.316	24.99
1910	-890	2.0	0.027	0.146	7.582	1830	-650	0.5	-0.190	0.111	2.923
1912	-870	2.0	0.159	0.116	3.802	1831	-630	0.5	0.148	0.348	39.38
1913	-840	2.0	-0.154	0.160	4.930	1832	-610	0.5	-0.268	0.123	9.548
1914	-810	2.0	-0.162	0.151	7.075	1833	-595	0.5	-0.301	0.208	7.082
1919	-770	4.0	0.072	0.210	7.561	1839	-645	0.6	-0.079	0.157	6.576
1916	-750	4.0	-0.019	0.120	4.032	1851	-630	0.6	-0.308	0.084	2.558
1917	-730	4.0	0.133	0.130	3.262	1841	-610	0.6	-0.424	0.134	5.048
1918	-710	4.0	-0.130	0.117	3.480	1842	-590	0.6	0.065	0.383	29.23
1920	-650	10.0	0.139	0.202	8.691	1826	-570	1.0	-0.325	0.190	7.729
1921	-630	10.0	0.071	0.150	4.912	1827	-555	1.0	-0.397	0.228	9.533
1922	-610	10.0	0.256	0.144	2.719	1828	-540	1.0	-0.460	0.221	15.22
1923	-590	10.0	0.223	0.195	6.154	1829	-520	1.0	-0.099	0.170	5.098
						1819	-500	2.0	-0.428	0.166	5.703
						1820	-490	2.0	-0.518	0.124	3.582
						1821	-475	2.0	-0.301	0.159	4.882
						1822	-460	2.0	-0.469	0.241	9.740

LL = 0.5 nA						LL = 10.0 nA					
Run	HV	PreAmp	non-Lin	Error	$\chi^2/6df$	Run	HV	PreAmp	non-Lin	Error	$\chi^2/6df$
1863	-1040	0.5	0.393	0.039	0.7648	1786	-780	0.1	0.038	0.139	9.707
1865	-1010	0.5	0.289	0.108	4.324	1785	-760	0.1	0.333	0.330	21.84
1866	-980	0.5	0.238	0.051	0.9041	1782	-740	0.1	-0.163	0.244	18.23
1867	-950	0.5	0.360	0.202	19.54	1783	-720	0.1	-0.160	0.187	11.51
1857	-1000	0.6	0.393	0.064	1.595	1787	-780	0.1	0.262	0.204	22.53
1859	-970	0.6	0.354	0.095	3.488	1788	-760	0.1	-0.057	0.092	3.948
1860	-940	0.6	0.525	0.212	15.26	1789	-740	0.1	-0.060	0.247	20.74
1861	-920	0.6	0.297	0.142	5.493	1790	-720	0.1	-0.417	0.122	7.334
1868	-900	1.0	0.344	0.269	29.49	1791	-660	0.3	-0.743	0.171	5.325
1869	-880	1.0	0.170	0.184	11.66	1792	-640	0.3	-0.698	0.241	12.76
1870	-850	1.0	0.331	0.062	0.7265	1793	-620	0.3	-0.672	0.380	23.75
1872	-830	1.0	0.055	0.231	13.05	1794	-600	0.3	-0.885	0.325	35.99
1873	-800	2.0	0.206	0.148	5.657	1799	-590	0.5	-0.920	0.274	26.76
1874	-780	2.0	0.055	0.144	7.464	1800	-570	0.5	-0.901	0.271	16.07
1875	-760	2.0	0.113	0.114	3.686	1801	-550	0.5	-1.015	0.320	33.61
1876	-740	2.0	0.469	0.237	16.29	1802	-530	0.5	-1.231	0.265	14.08
1877	-700	4.0	0.095	0.157	6.243	1795	-575	0.6	-1.042	0.254	10.40
1878	-680	4.0	0.097	0.114	2.977	1796	-555	0.6	-1.205	0.164	5.487
1879	-660	4.0	0.053	0.146	4.984	1803	-535	0.6	-1.378	0.253	16.20
1881	-640	4.0	-0.130	0.166	8.138	1798	-520	0.6	-1.446	0.374	21.15
1883	-590	10.0	-0.266	0.130	3.332	1804	-520	1.0	-0.998	0.411	29.96
1884	-570	10.0	0.166	0.124	3.616	1805	-505	1.0	-1.421	0.379	23.99
1885	-550	10.0	-0.237	0.186	6.346	1806	-490	1.0	-1.506	0.458	25.02
1886	-530	10.0	-0.009	0.197	5.260	1807	-480	1.0	-1.780	0.528	53.54
						1808	-460	2.0	-1.530	0.253	12.60
						1809	-450	2.0	-1.865	0.252	16.29
						1810	-435	2.0	-1.870	0.376	26.69
						1811	-425	2.0	-1.823	0.348	17.32

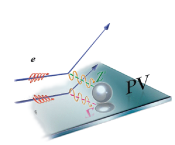

Plans for MOLLER pmt Linearity Measurements

- Apparatus and technique validated for PREX pmts at 240 Hz ff
 - Conclusion: want pmt $I_C \lesssim 15\text{nA}$ and $I_A \sim 20 - 30 \mu\text{A}$
 - Anticipate $< 0.5\%$ non-linearity systematic for PREX-II and even better for CREX
 - Measurements routinely find HV and preamp settings with non-linearity deviations at 0.1 - 0.2% level
- While 30, 120, and 240 Hz ff data give very similar/same results, we see differences at 480 Hz ff—possibly a result of thermal or other instabilities in the flashing LED
- To address expected problems at 960 Hz ff, we plan to implement a chopper wheel setup with phase-locked controller to shutter the LED instead of flash it (M. Gericke's idea)

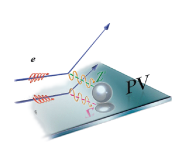

Plans for MOLLER pmt Linearity Measurements

- ISU group has two ET 9305KQB pmts with factory bases in hand to start testing this fall
 - Anticipated light levels or PE (I_C) currents for central-open ring5 pmts at ~ 16 nA (~ 4 GHz, ~ 25 PEs/ e^-)
 - Will require custom tuned base divider to achieve desired 0.1% non-linearity
 - M. Gericke and group will design bases for future tests; for now, two different factory bases were purchased: one standard circuit and one tapered (for high pulsed linearity)
- A non-trivial complication for precision measurements is calibrating the incident light level or photocathode current. We use special unity gain bases for PREX/CREX; need this for MOLLER

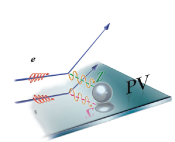

More Backup Slides

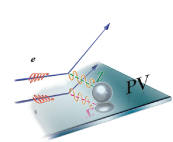

Shower-max phi-segmentation, rates and energies

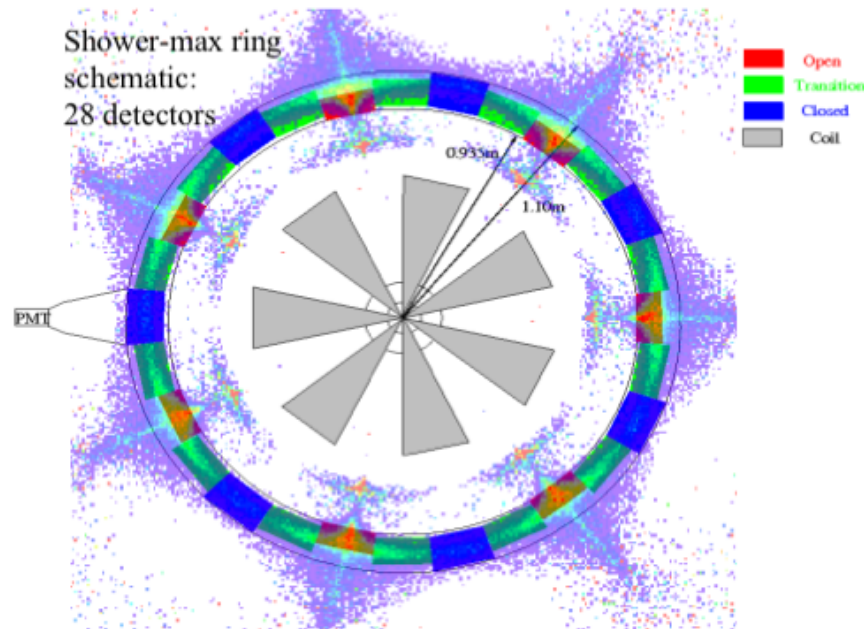
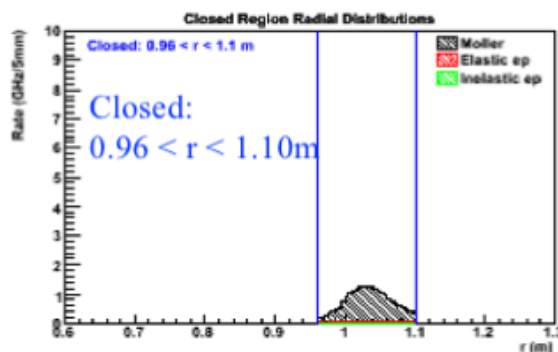
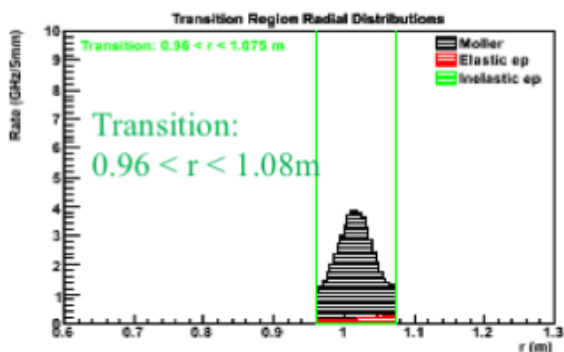
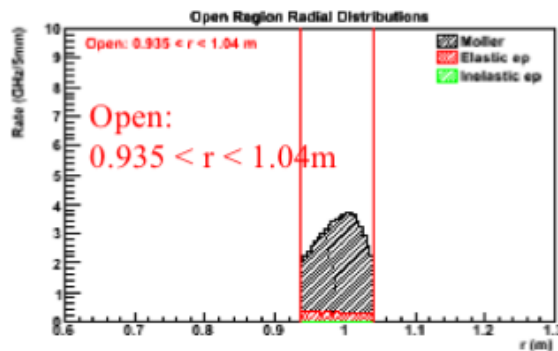
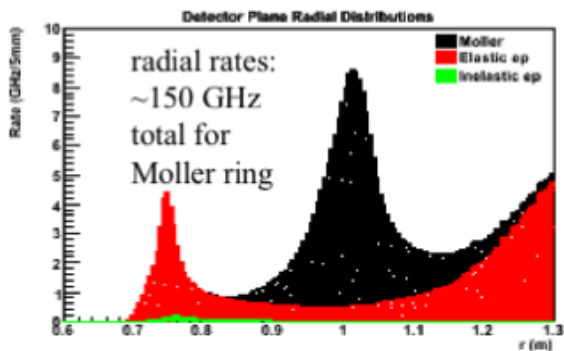

- Large range of rates and energies for different phi-region detectors:
 - Open ~9 GHz/det; 2 - 9 GeV, peak at 7 GeV...
 - Closed ~3.5 GHz/det; 2 - 5 GeV, peak at ~3 GeV
 - Transition ~4.5 GHz/det; 2 - 7 GeV, 3 - 5 GeV plateau

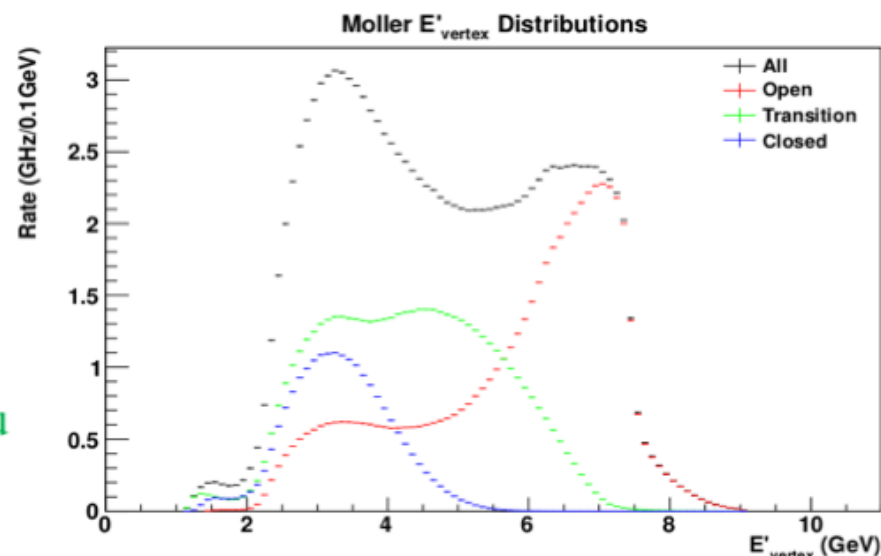

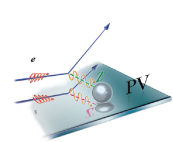

Baseline Design Stack and Light Guide Concepts

- Detector concept uses a layered “stack” of tungsten and fused silica (quartz) to induce EM showering and produce Cherenkov light
- “Baseline” design developed using GEANT4 optical MC simulation:
 - Current design uses a **4-layer stack** with **8 mm tungsten** and **10 mm quartz** pieces
 - Cherenkov light directed to **3 inch PMT** using **air-core, aluminum light guide**

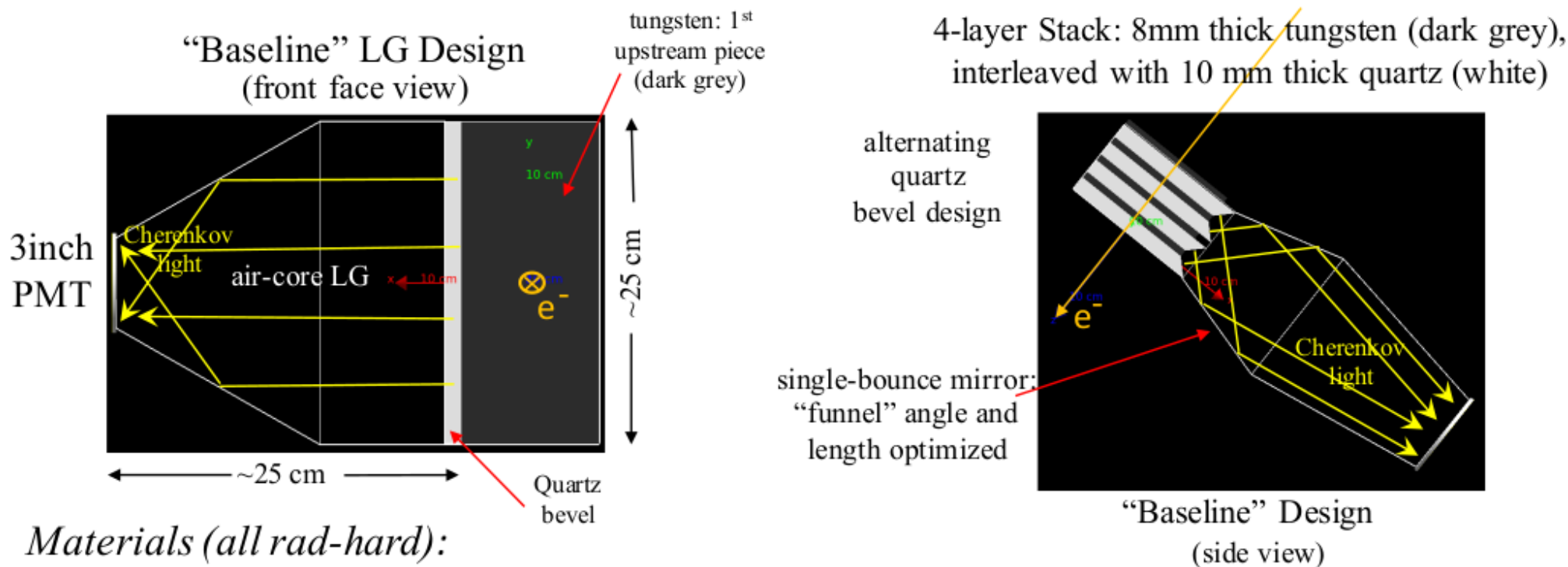

Materials (all rad-hard):

- Tungsten is high purity (99.95%) and quartz is optically polished Spectrosil 2000
- Light guides are aluminum specular reflectors (Miro-silver 27, Anolux, or al. mylar, ...)
- Total radiation length: $9.1 X_0$ tungsten + $0.4 X_0$ quartz = $9.5 X_0$

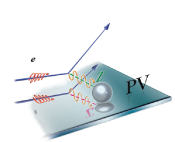

Quartz and Tungsten Ordered in Nov 2017

- For “benchmarking” prototype stack:
 - Quartz: 6 mm (thick) by 86 mm (tall) by 40 mm (wide) --4 pieces (\$975/piece = \$3.9k)
 - Quartz: 10 mm (thick) by 90 mm (tall) by 40 mm (wide) --4 pieces (\$1005/piece = \$4.0k)
 - Tungsten: 6 mm (thick) by 80 mm (tall) by 40 mm (wide) – 4 pieces (\$85/piece = \$340)
 - Tungsten: 8 mm (thick) by 80 mm (tall) by 40 mm (wide) – 4 pieces (\$110/piece = \$440)
 - Tungsten: 2 mm (thick) by 80 mm (tall) by 40 mm (wide) – 4 pieces (\$25/piece = \$100)
- For “full-scale” prototype stack:
 - Quartz: 6 mm (thick) by 111 mm (tall) by 246 mm (wide) -- 4 pieces (~\$1750/piece = \$7.0k)
 - Quartz: 10 mm (thick) by 115 mm (tall) by 246 mm (wide) -- 4 pieces (~\$1940/piece = \$7.8k)
 - Tungsten: 6 mm (thick) by 105 mm (tall) by 246 mm (wide) – 4 pieces (\$600/piece = \$2.5k)
 - Tungsten: 8 mm (thick) by 105 mm (tall) by 246 mm (wide) – 4 pieces (\$820/piece = \$3.2k)
 - Tungsten: 2 mm (thick) by 105 mm (tall) by 246 mm (wide) – 4 pieces (\$200/piece = \$0.8k)

Purchasing these pieces allows for Configs 1, 3, and 4 (A and B) to be tested

Total quartz: \$25k, total tungsten: \$7.5k: Total = \$32.5k

- This purchase enables construction of two benchmarking and two full-scale prototype sets
- Building two sets of prototypes will allow for more efficient testing during both SLAC testbeam and cosmic tests at SBU and ISU. We can each build a different configuration to test

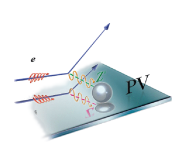

MOLLER Task Tracking: ISU Tasks

Subsystem	Task	Description	Status	Owner	Relation to Director's Review Report	Estimated Completion Date
Detectors	Radiation hardness of detector components	Investigate which detector components need radiation testing and carry out 50 MRad test	Michael and Dustin devise a plan. Status: Initial list being established	Dustin	Page 12: "..., all components in the scattered beam envelope should show negligible damage up to 50 MRad."	May 2019
Detectors	QC plan for main detector quartz	Devise plan to evaluate robustness of main detector quartz (Redundant with "radiation hardness of detector components")	Michael and Dustin to devise a plan? Not yet started	Dustin	Page 12: Recommendation: "Conduct radiation damage tests to at least 50 MRad to qualify fused silica for use in the thin detector"	May 2019
Detectors	Shower-Max module mechanical assembly design	This task incorporates the physical design and prototyping of the showerMax detector, as well as the associated mechanical mounting structure	Advanced state of first prototype design, including mechanical assembly	Dustin	Not explicitly mentioned	May 2018

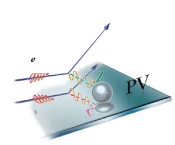

Radiation Hardness Test plan Update

- Radiation hardness testing of mechanical assembly materials and parts (ISU, UM)
 - ❖ Irradiated several light-guide (LG) material samples over a 3 day test run from Mar 22 - 24, 2016 at the Idaho Accelerator Center (IAC) using 8 MeV, 65 mA I_{peak} , 4 μ s pulse width at 250 Hz rep-rate (dose exposure rate was calculated but too high to measure):
 - Measured LG specular reflectivity for 200 – 800 nm at 90, 60, 45, and 30 degrees.
 - No measurable change in reflectivity was detected for $\gg 50$ MRad exposure
 - ❖ Other assembly materials to test could include Kapton and Tedlar (light tight wrappings) and possibly 3D-printed custom plastic assembly components (Nylon, ABS, PLA, ...) as well as high-density shielding plastics, epoxies, ...
- Radiation hardness testing of electronic components: active bases, preamps, ... (ISU, UM)
- Main Detector Quartz Robustness (radiation hardness, QA, etc.) (ISU, UM)
 - ❖ Apparatus developed to make relative transparency measurements between 200 – 800 nm
 - Uses Ocean Optics USB spectrometer, UV-Visible light source, custom holder/stand
 - ❖ Energy deposition calculations (dE/dx and brem) underway for 8 MeV beam and 1.5 cm thick quartz—for heating and thermal expansion considerations (do not want to crack quartz)
 - ❖ Developed plan to calibrate and monitor beam dose exposure during study
 - ❖ Had a 1 day IAC test run on May 31, 2018; dose exposure rates calibrated; performed preliminary quartz irradiation test

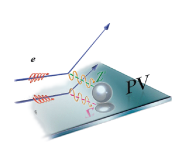

Radiation Hardness QA for quartz and other components

25 MeV LINAC (Main Hall and Airport)

RF Frequency: 2856 MHz (S-Band)
 Energy Range: ~4~25 MeV (current varies)
 Pulse Width: ~50ns to 4 micro seconds
 Repetition Rate: single pulse to 360 Hz
 Ports: 0 degree, 45 degree and 90 degree (Beam energy resolution ~ 1+/- 15%)

25B Energy vs Current			
Energy (MeV)	0 port (mA)	45 port (mA)	90 port (mA)
23	55	55 @ 3.8uS	46 @ 3.6uS
20	100	70 @ 4 uS	65 @ 4 uS
16	100	48 @ 3.6 uS	48 @ 3.6 uS
13	80	30 @ 3.3 uS	15 @ 3.3uS
10	60	18 @ 3 uS	7.5 @ 3 uS
9	110	30 @ 4uS	15 @ 4 uS
6	100	60 @ 4 uS	60 @ 4 uS
4	50	20 @ 4 uS	20 @ 4 uS

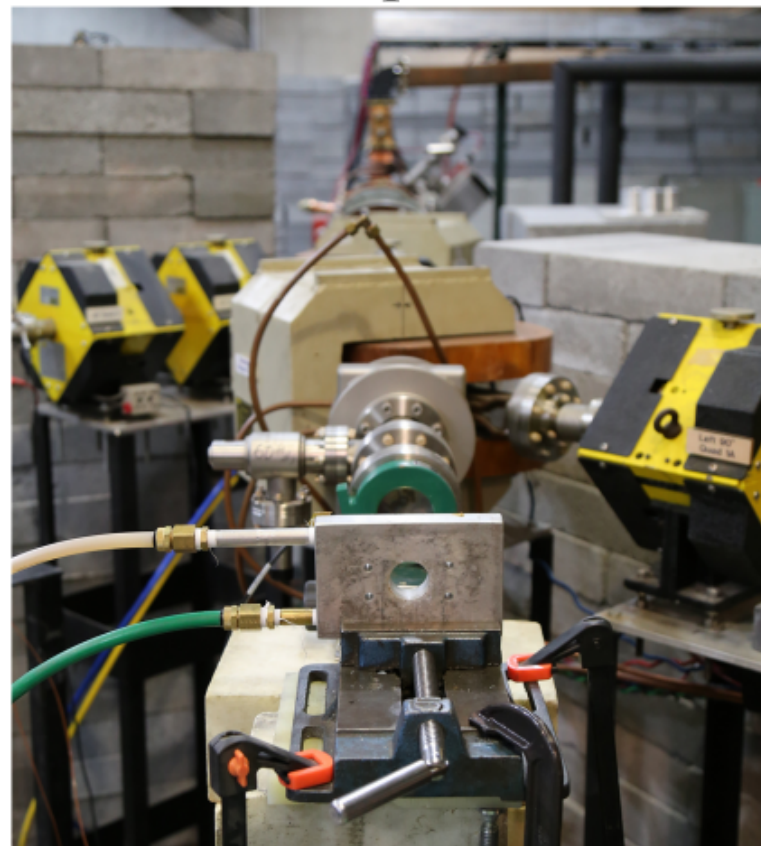
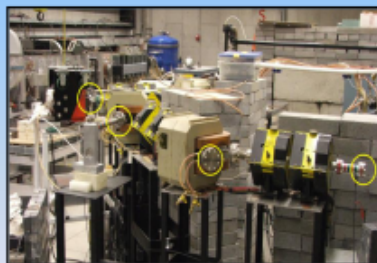

- The key issue is how well can we calibrate dose exposure?

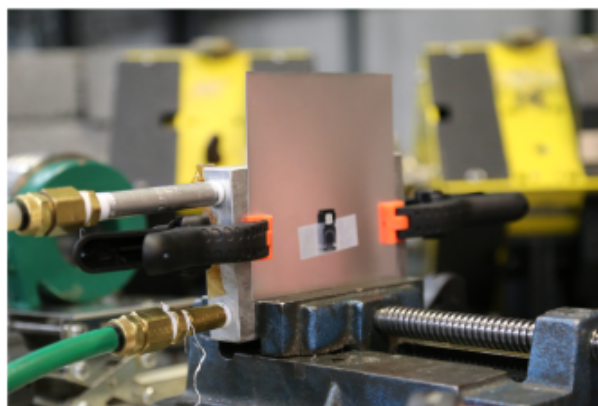

- Performed a 1 day engineering run this past spring to address this question as well as perform preliminary radiation hardness QA quartz studies

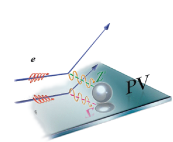

Radiation Hardness QA for quartz and other components

- Performed 1 day irradiation study on Spectrosil 2000 quartz and 3D printed ABS plastic samples
- Tests performed on May 31, 2018 at the Idaho Accelerator Center (IAC) using 8 GeV electrons
- Dose exposure rates calibrated using thermographic film dosimetry measurements
- Quartz transparency measurements taken at 10, 30, and 60 MRad exposure levels
- Plastic dogbones radiated at similar levels and tensile strength (stretching) measurements made

25 MeV LINAC (Main Hall and Airport)

RF Frequency: 2856 MHz (S-Band)

Energy Range: ~4~25 MeV (current varies)

Pulse Width: ~50ns to 4 micro seconds

Repetition Rate: single pulse to 360 Hz

Ports: 0 degree, 45 degree and 90 degree (Beam energy resolution ~ 1+/- 15%)

25B Energy vs Current

Energy (MeV)	0 port (mA)	45 port (mA)	90 port (mA)
23	55	55 @ 3.8 μ s	46 @ 3.6 μ s
20	100	70 @ 4 μ s	65 @ 4 μ s
16	100	48 @ 3.6 μ s	48 @ 3.6 μ s
13	80	30 @ 3.3 μ s	15 @ 3.3 μ s
10	60	18 @ 3 μ s	7.5 @ 3 μ s
9	110	30 @ 4 μ s	15 @ 4 μ s
6	100	60 @ 4 μ s	60 @ 4 μ s
4	50	20 @ 4 μ s	20 @ 4 μ s

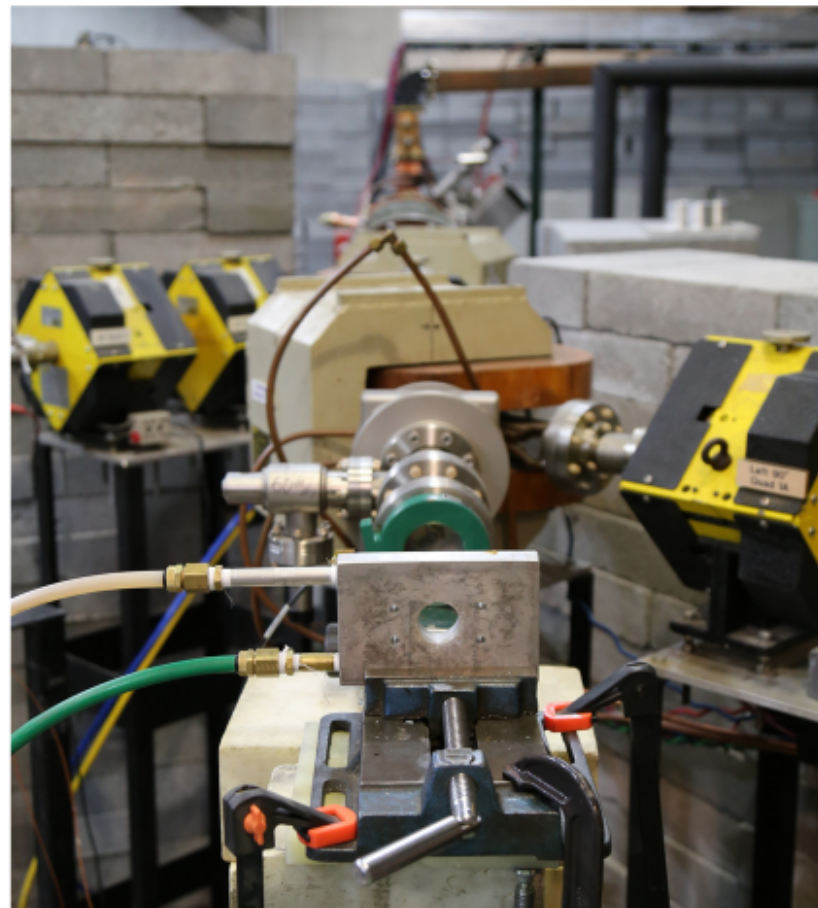
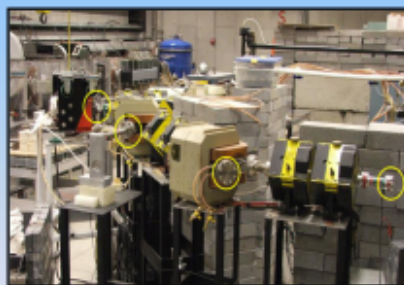

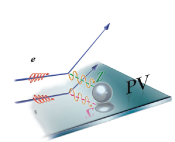

Beam Dose Exposure Rate Calibrations (May 2018)

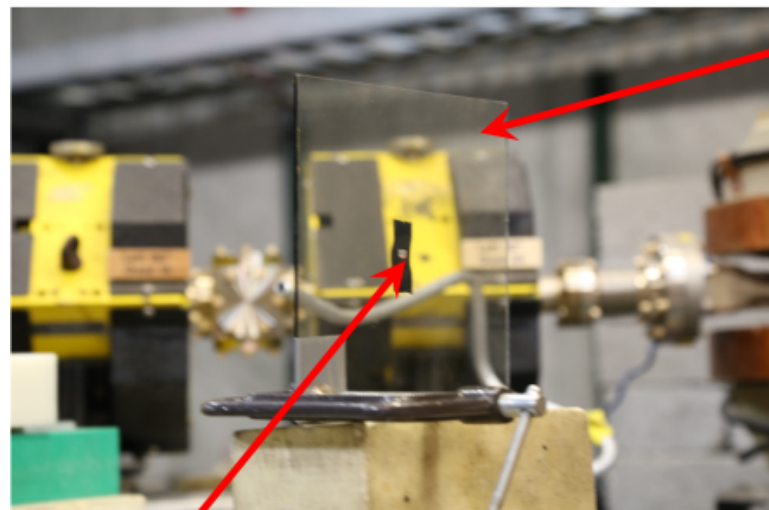

Glass slide for spot profile measurements

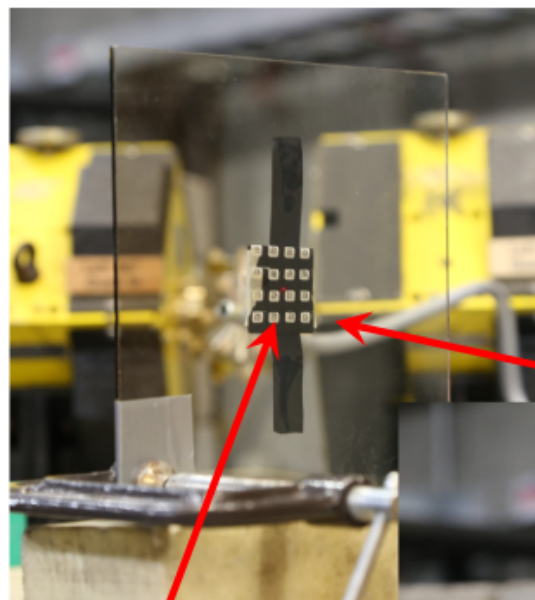

ISU MS degree student Connor Harper's thesis based on this work:
<https://www2.cose.isu.edu/~mcnudust/publication/studentWork/connorHarperThesis.pdf>

OSL arrays for dose profile measurements

Optically Stimulated Luminescence (OSL) dosimeter (~ 7 mm by 7 mm square)



Laser alignment

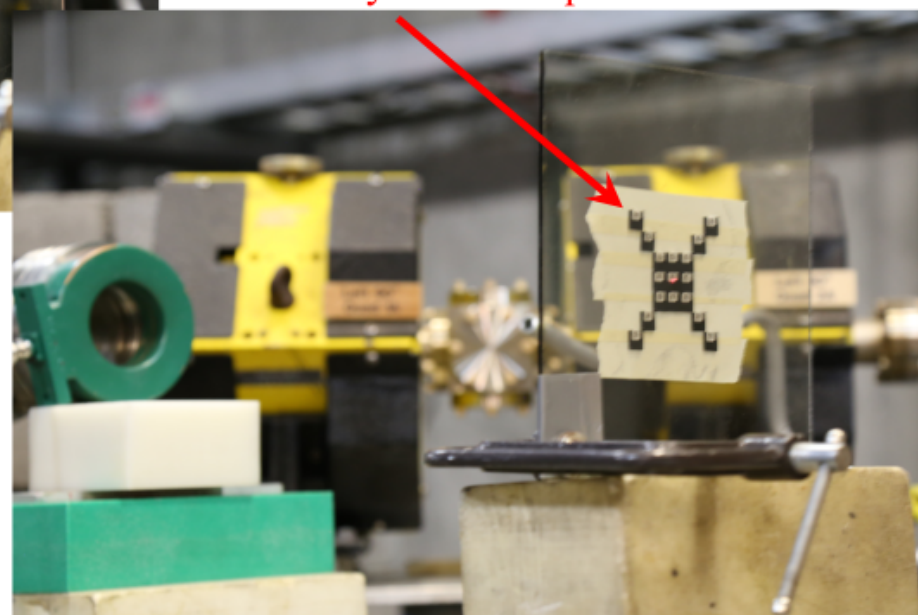

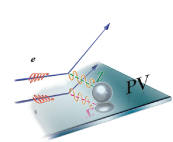

Quartz Irradiations (May 2018)

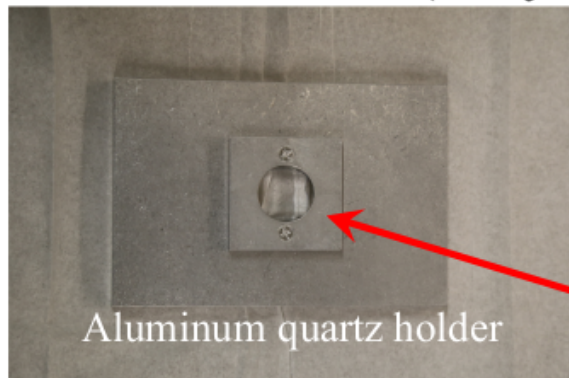
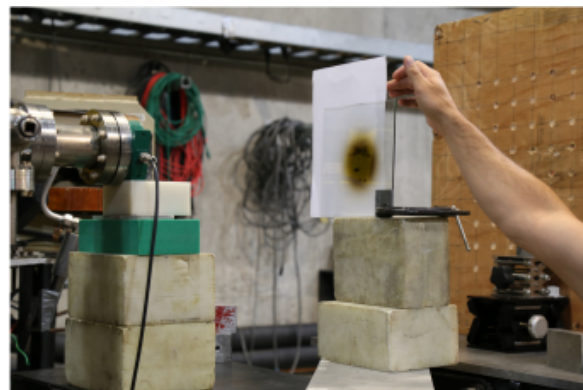

Aluminum quartz holder

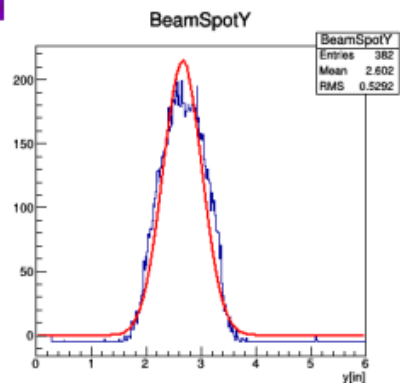
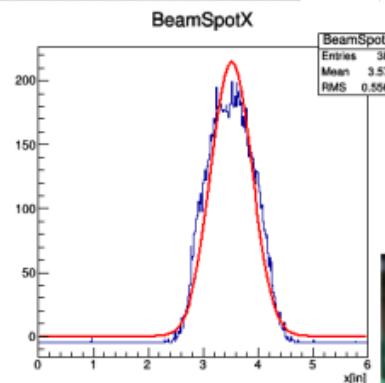
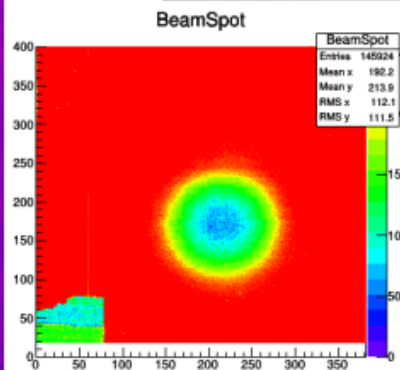
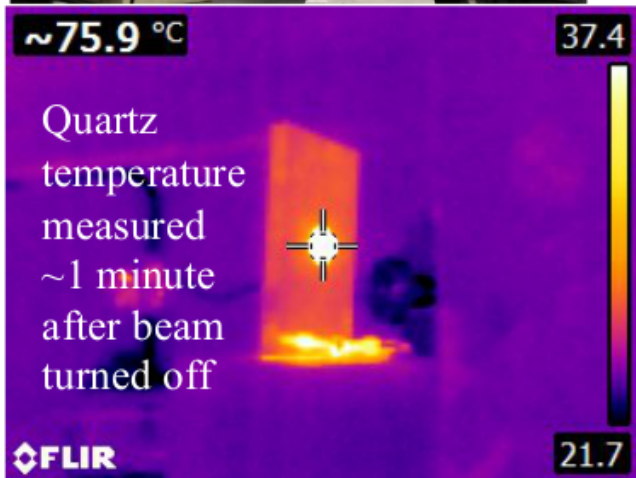
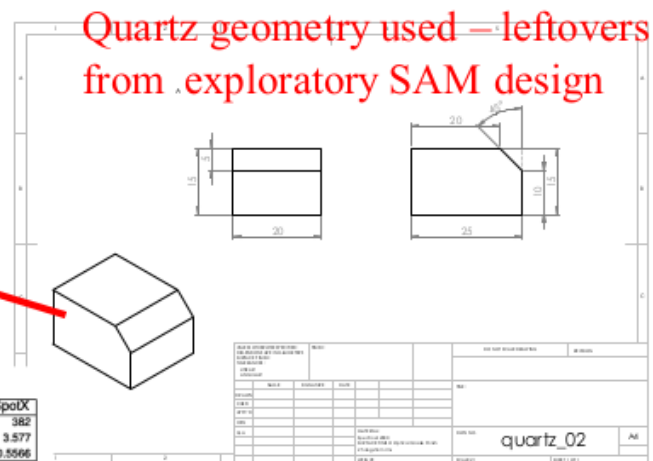

2018-05-31_15-01_Pulses_1006_50cm.png
 x-center = 3.512 in, y-center = 2.661 in
 glass plate at 50cm from beam window

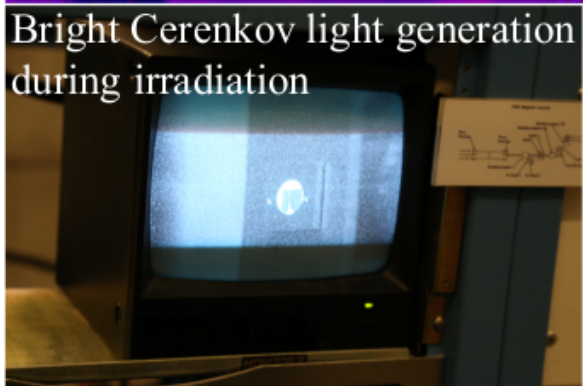

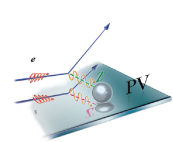

Quartz Transparency Measurements

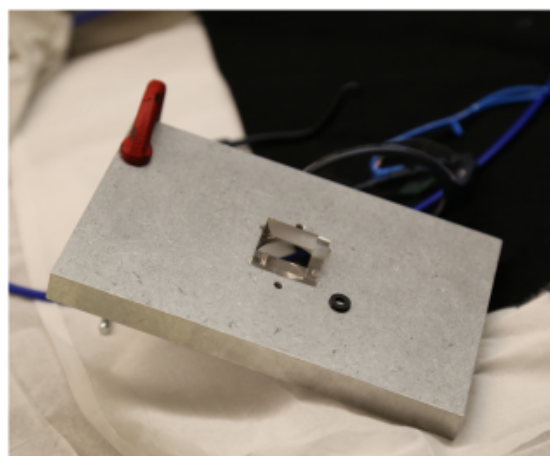
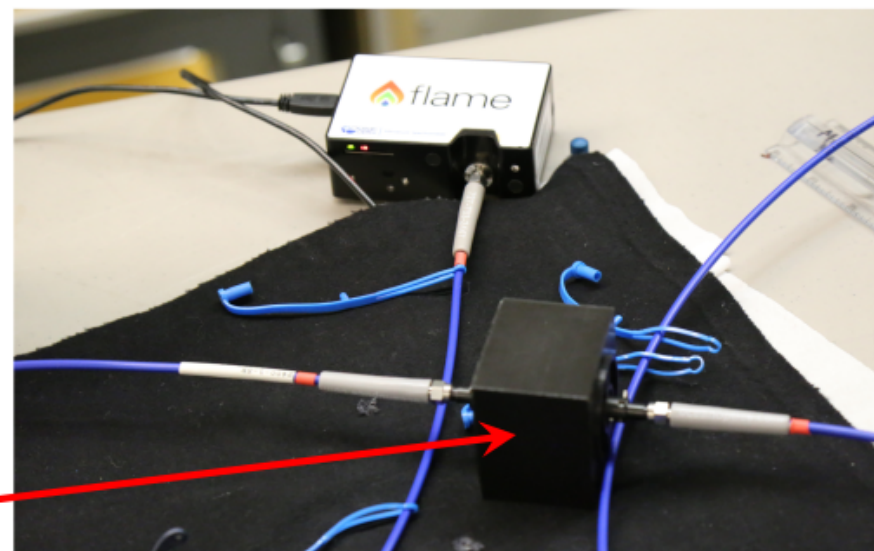
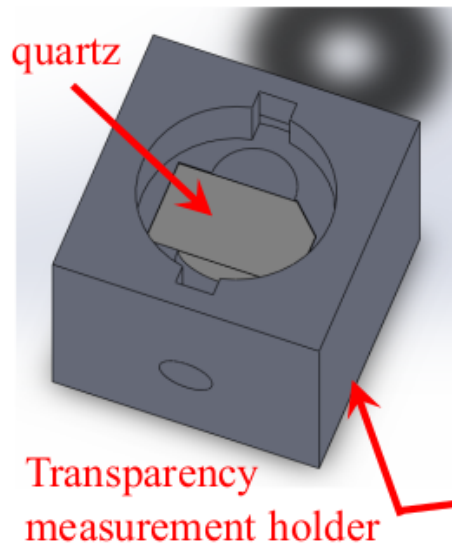
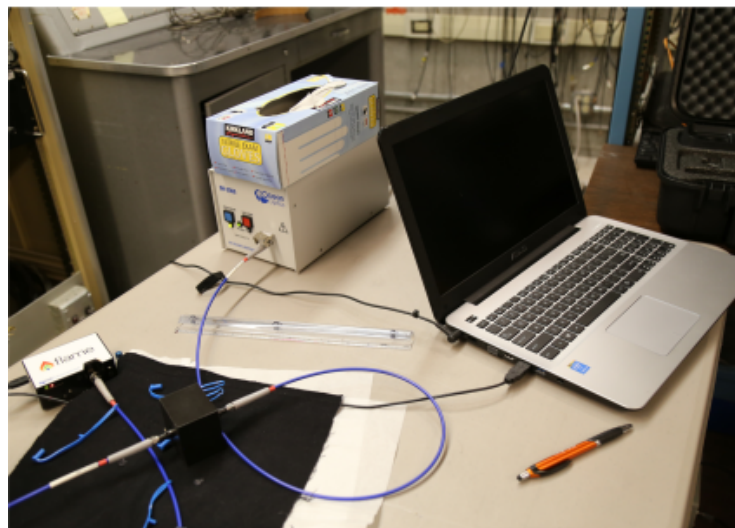

Means of All Irradiation Levels

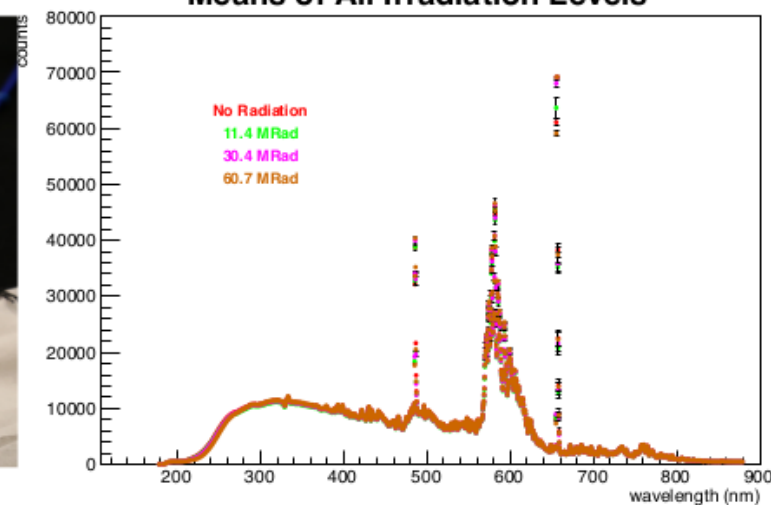

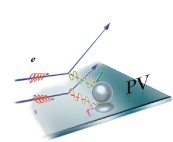

Quartz Transparency Preliminary Results

Means of All Irradiation Levels

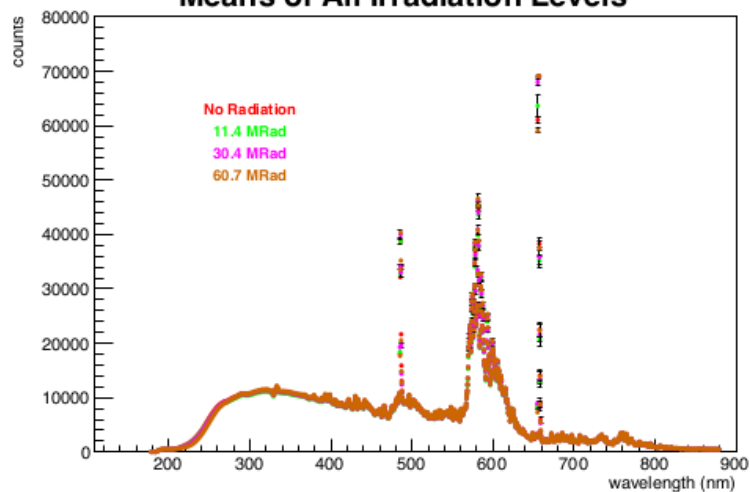

- Beam setup: 8 MeV, 50 mA I_{peak} , 500 ns pulse width at 250 Hz rep-rate
- Quartz sample mounted 0.5 m from beampipe exit window
- Dose exposure calibrations give ~ 253 Rad/pulse
- Irradiated sample for 3, 8, and then 16 minutes
- Measured light transmission (four times) after each irradiation and averaged

Unirradiated minus Irradiated

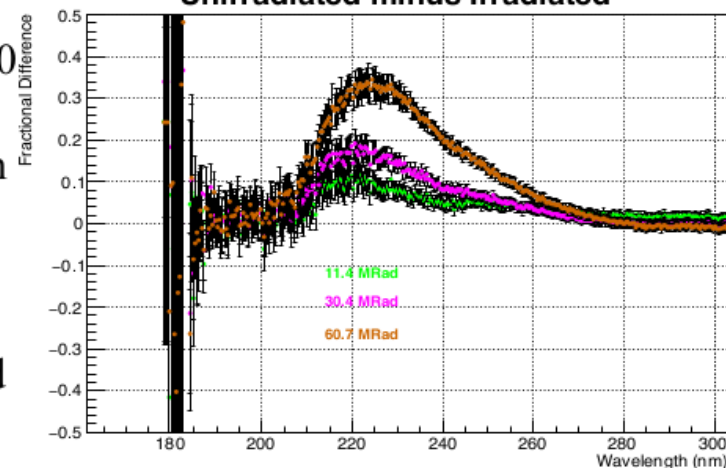

Unirradiated minus Irradiated

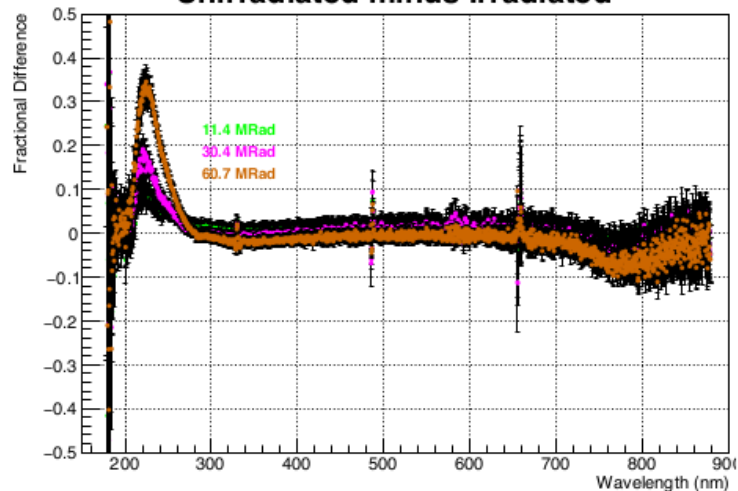

Systematic Error

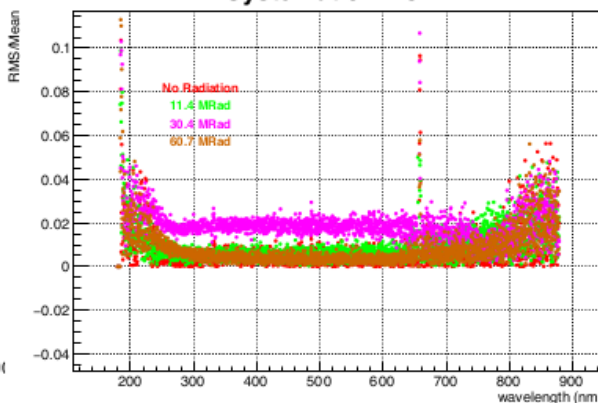

Unirradiated minus Irradiated

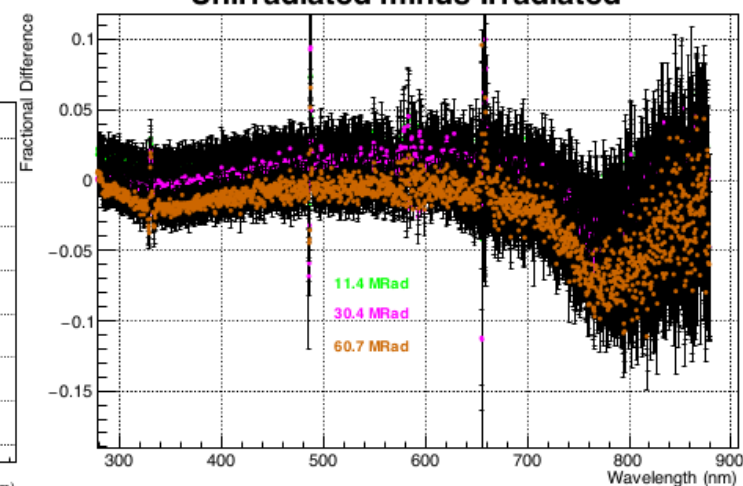

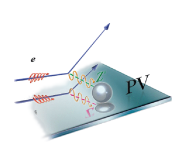

Quartz Rad Hardness Preliminary Results Summary

- Apparent onset of radiation damage seen in the UV region (between 200 – 270 nm)
- These results need to be double-checked:
 - Perform more in-depth future irradiation study
 - Examine a few different pieces (same geometry), perform more transparency measurements at smaller intervals of exposure, and redesign apparatus to give less systematic variations

• We've already seen from reflectivity measurements, combined with MAMI testbeam results, that the deep UV part of the spectrum does not seem as important or contributing as the UV/Vis part--due to cathode sensitivity and QE

• Perhaps a measurement using a SAM-type or even Moller ring-5 prototype detector during irradiations could show how this effect is dampened by the PMT; use a cathode with very low QE in the < 280 nm region

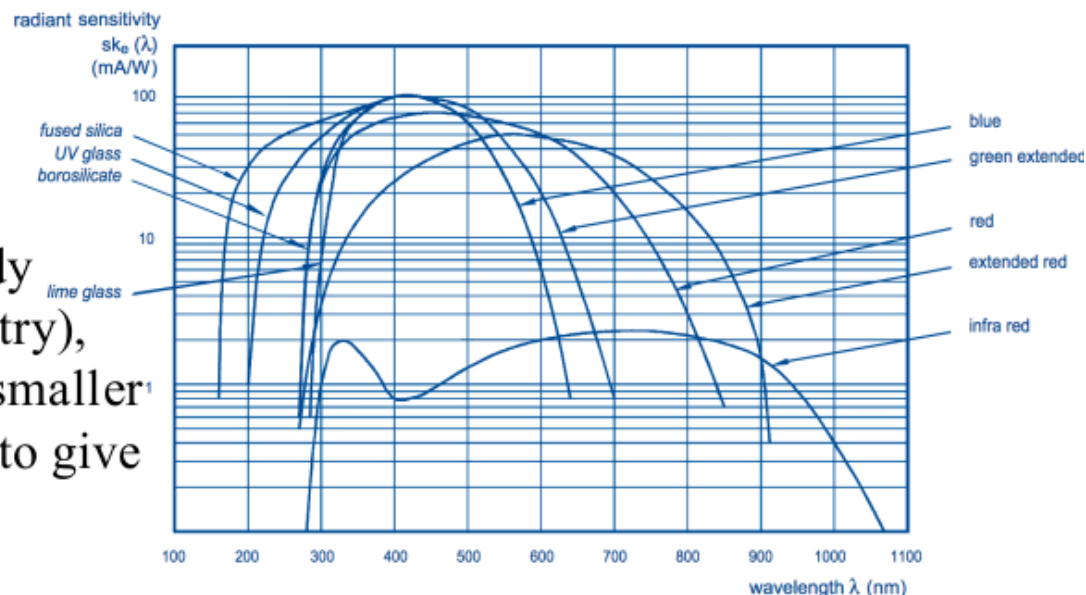
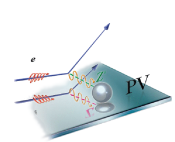

Fig.2 Typical spectral sensitivity characteristics of standard photocathodes with associated window materials.

$$QE (\%) \approx \frac{124}{\lambda(\text{nm})} \times \text{radiant sensitivity (mA/W)}$$

PMT Window Characteristics

type of window glass	cut-off wavelength, -10% (nm)	refractive index
lime glass	300	1.54 (at 400 nm)
borosilicate	270	1.50 (at 400 nm)
UV glass	190	1.49 (at 400 nm)
fused silica	160	1.47 (at 400 nm)
		1.50 (at 250 nm)
sapphire	150	1.80 (at 400 nm)



Simulated Yields from Photons (1A Full-scale)

ShowerMax 1A Photon Response

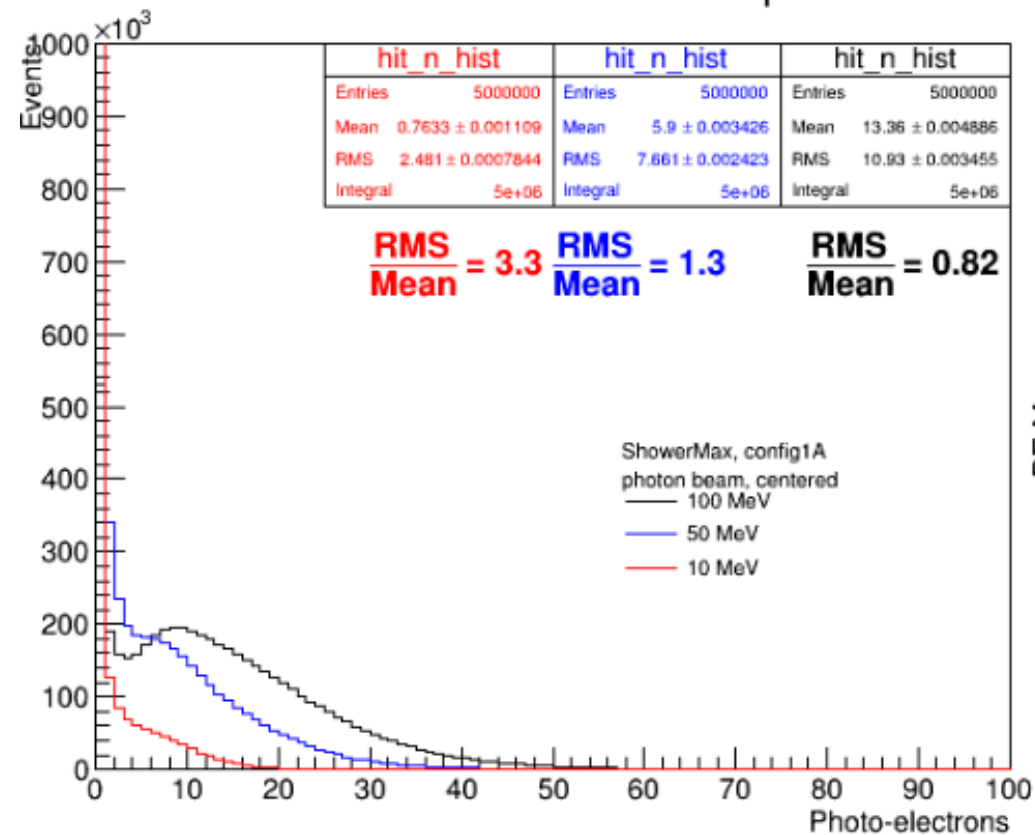

Config 1A - Photon Beam

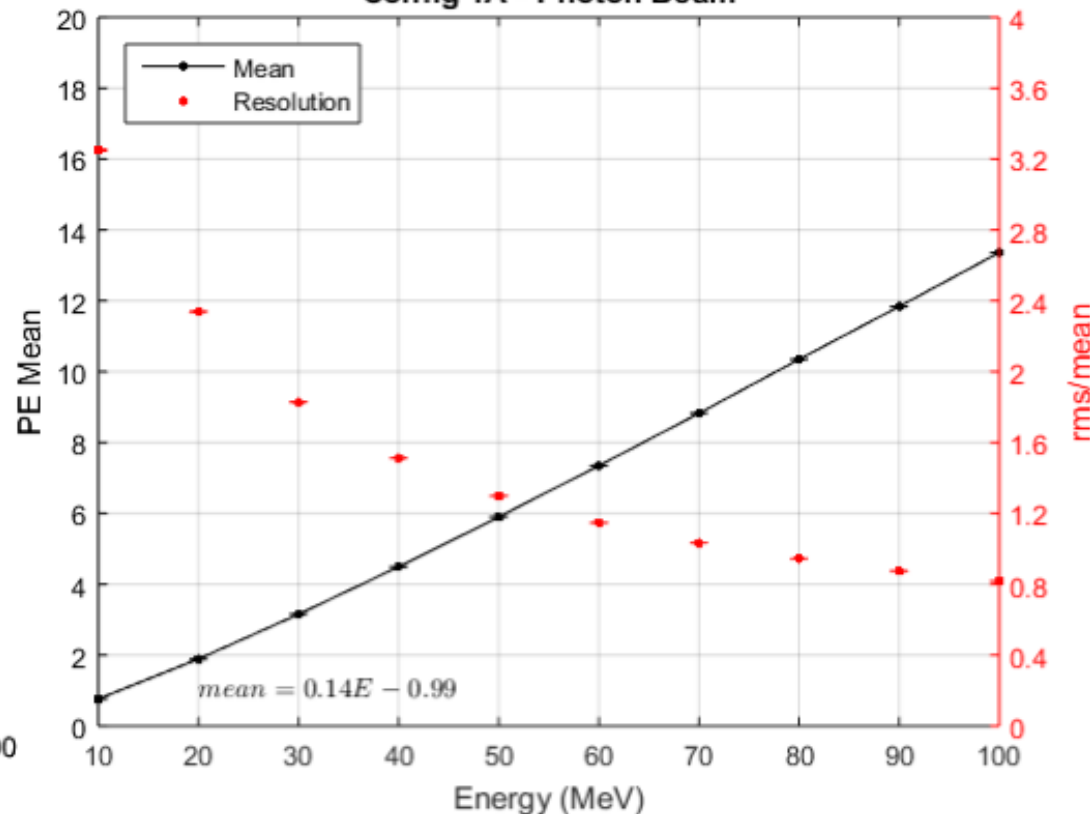

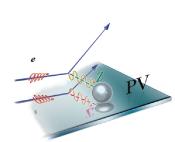

Simulated Yields from Pions (1A & 1B Full-scale)

ShowerMax Pion Response

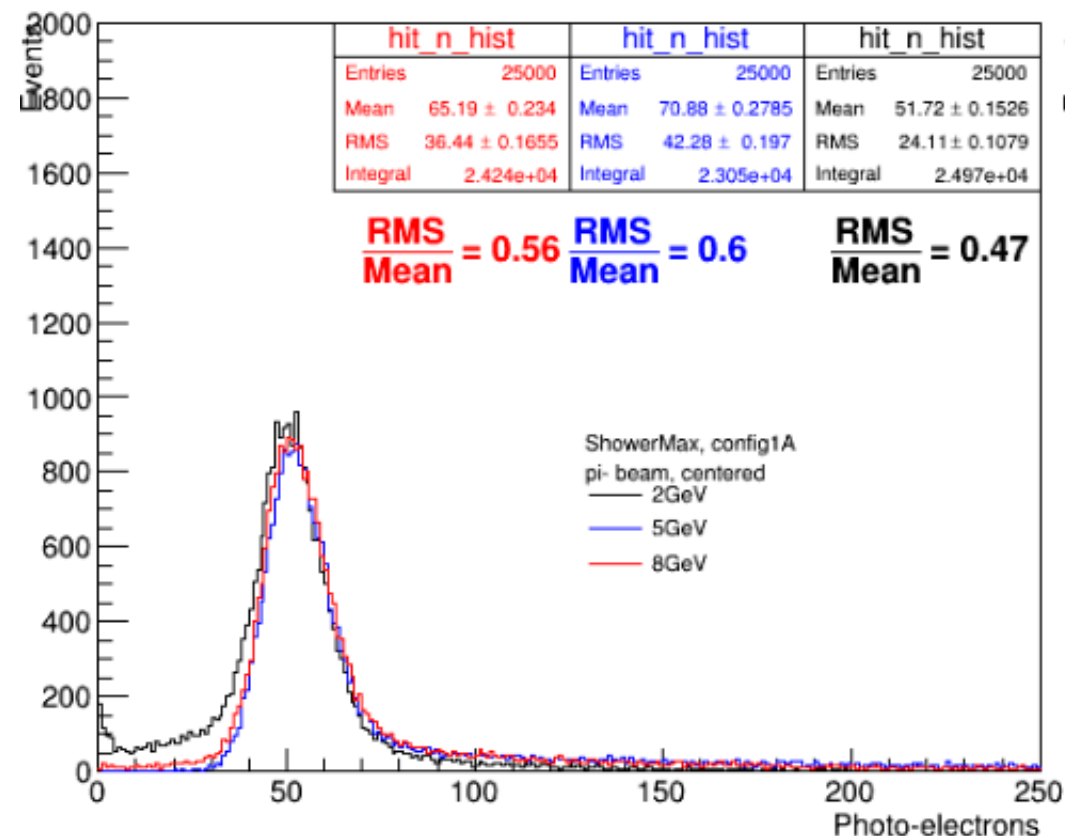

ShowerMax Pion Response

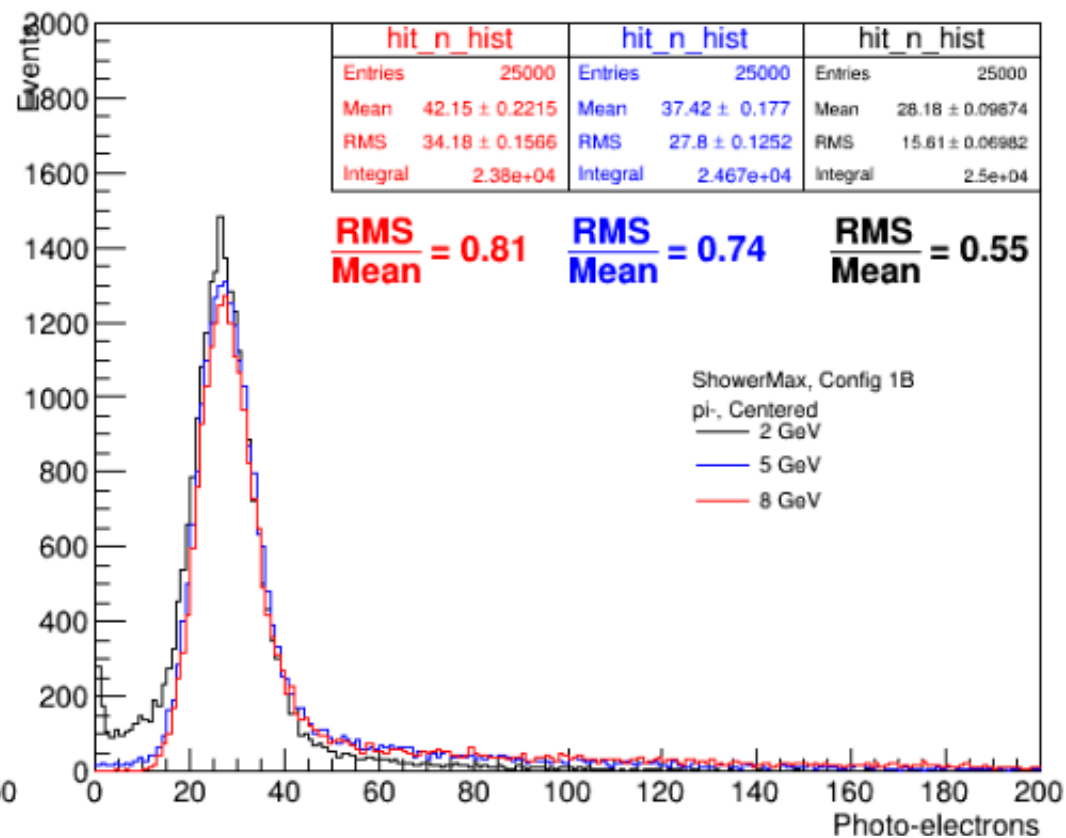

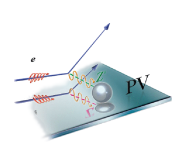

Simulated MIP signal for cosmic-ray tests (Full-scale)

ShowerMax - 1 GeV Muons

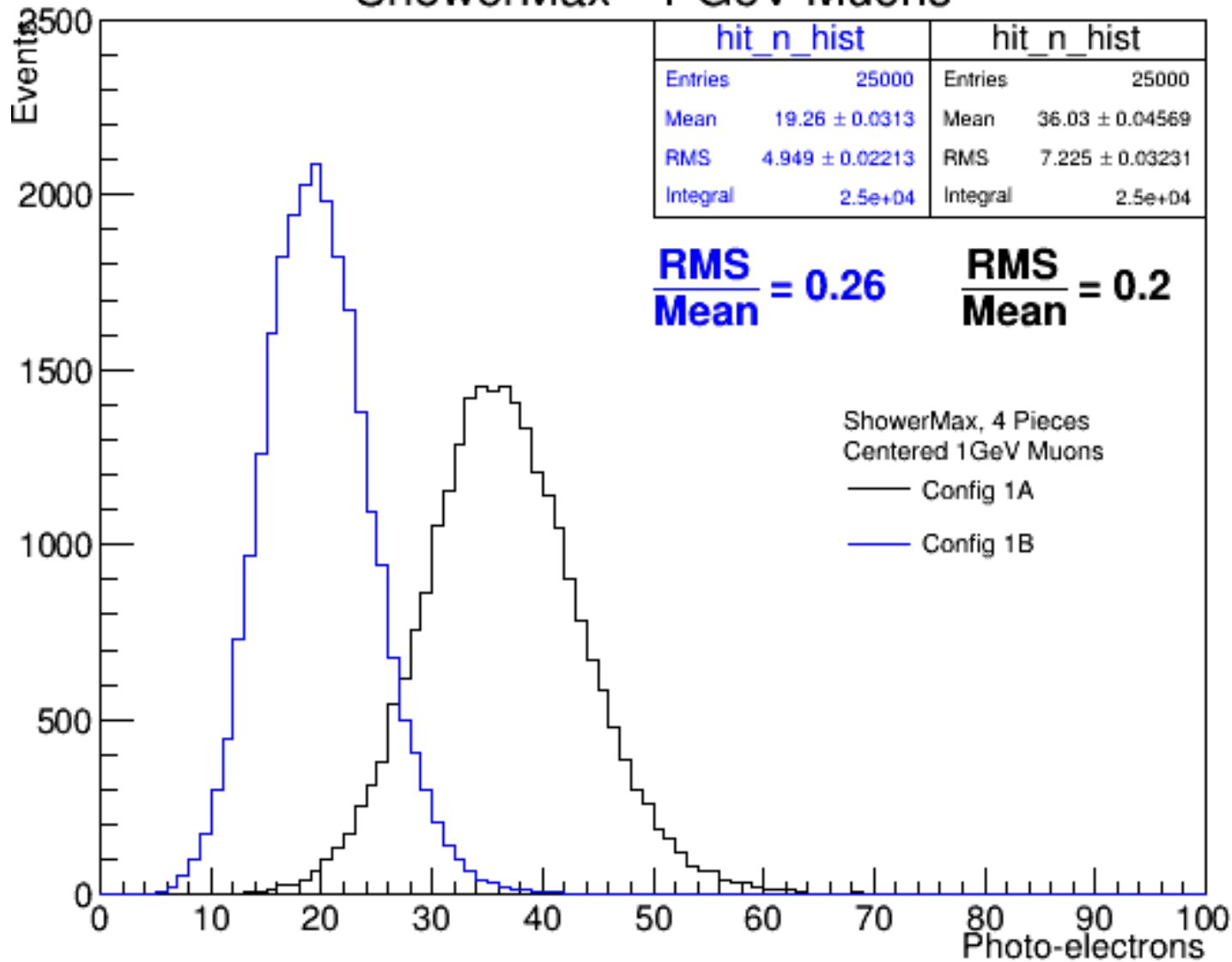

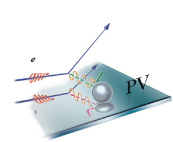

Uniformity Studies: 1A PE means along ϕ and r

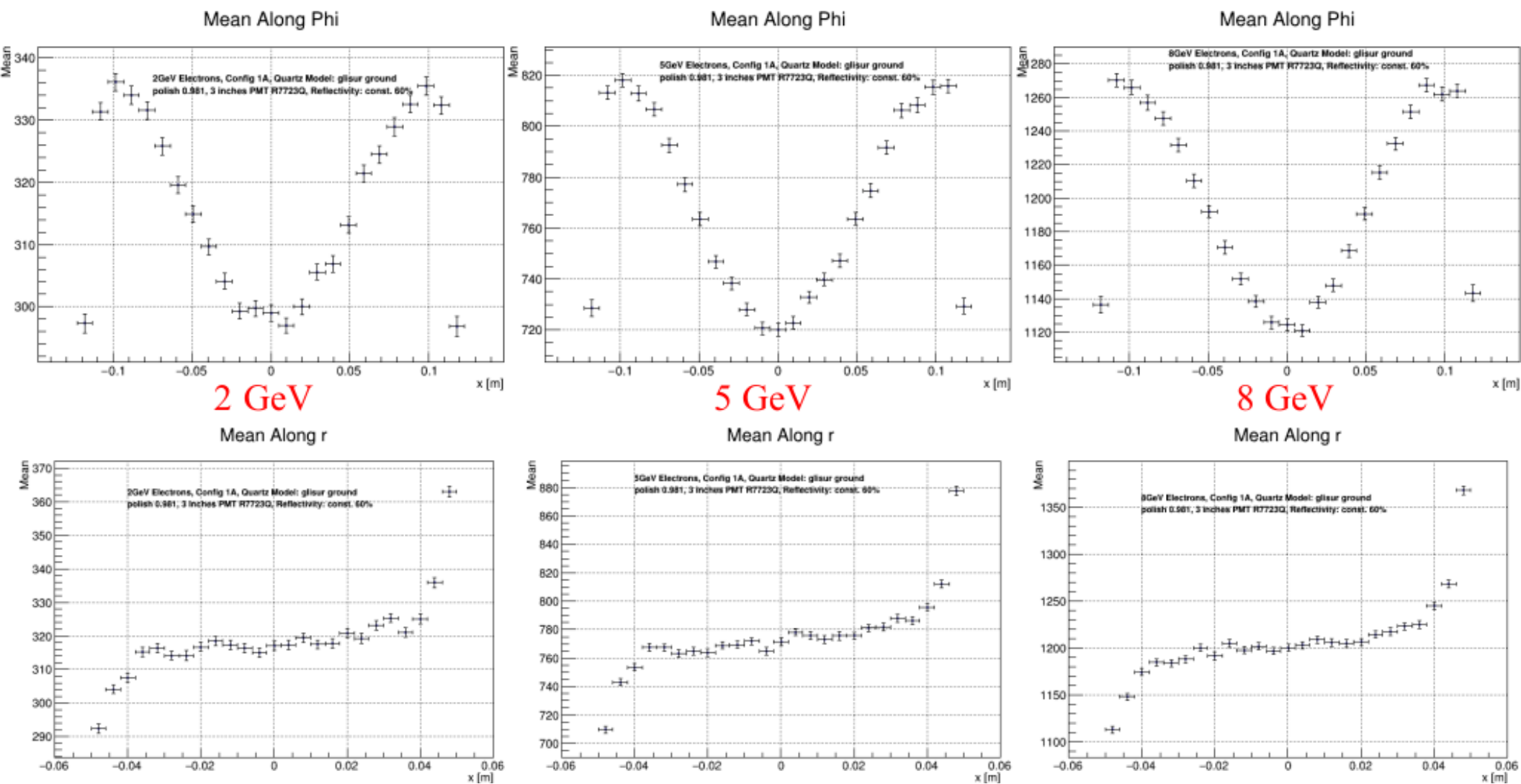

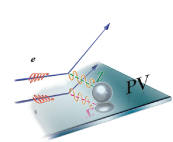

Uniformity Studies: 1A Resolutions along ϕ and r

Resolution Along Phi

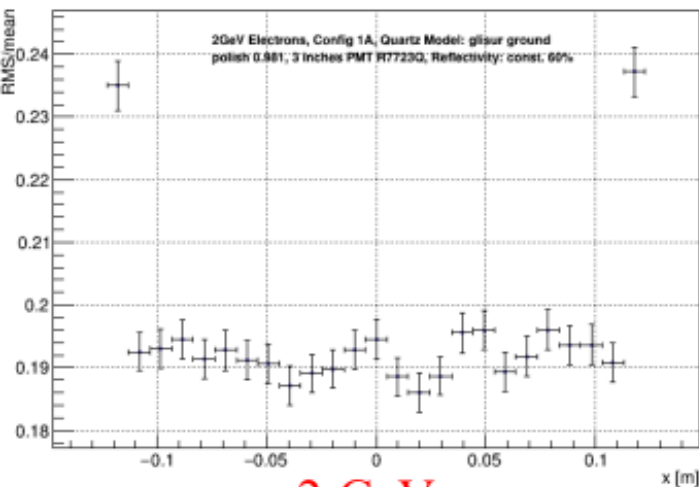

2 GeV

Resolution Along r

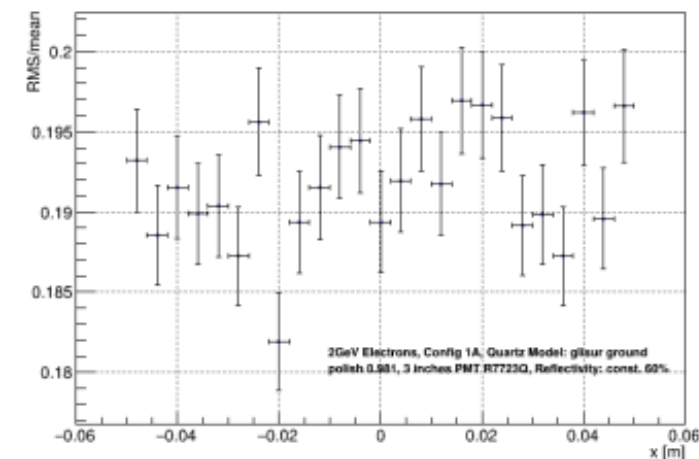

Resolution Along Phi

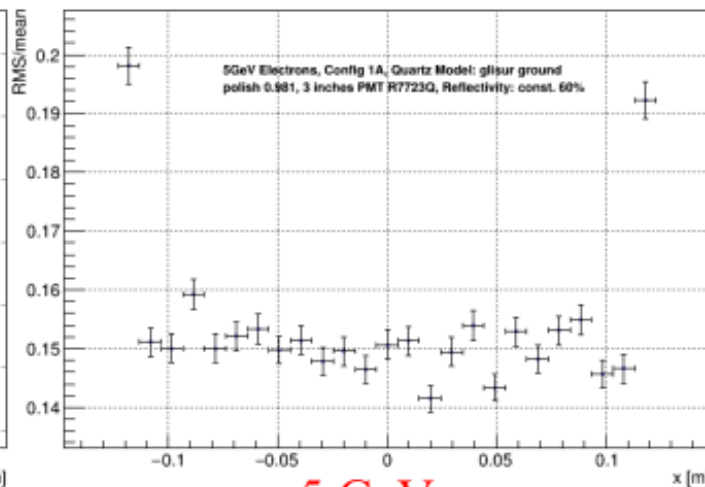

5 GeV

Resolution Along r

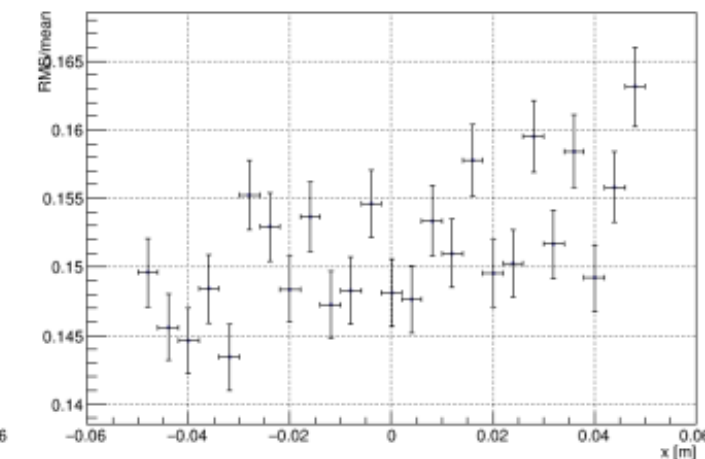

Resolution Along Phi

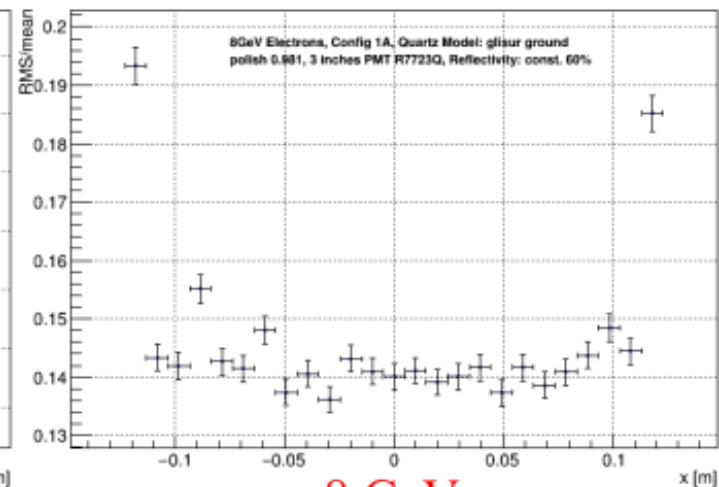

8 GeV

Resolution Along r

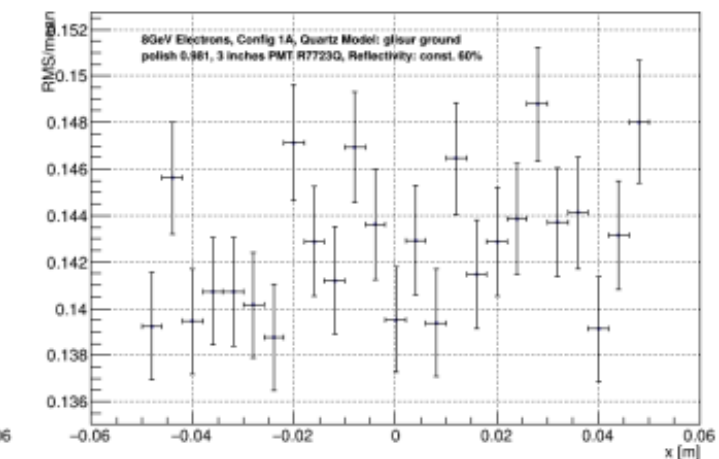

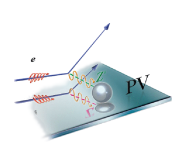

Candidate Design for Stack Prototype: Config #2

Non-uniform Benchmarking Showermax

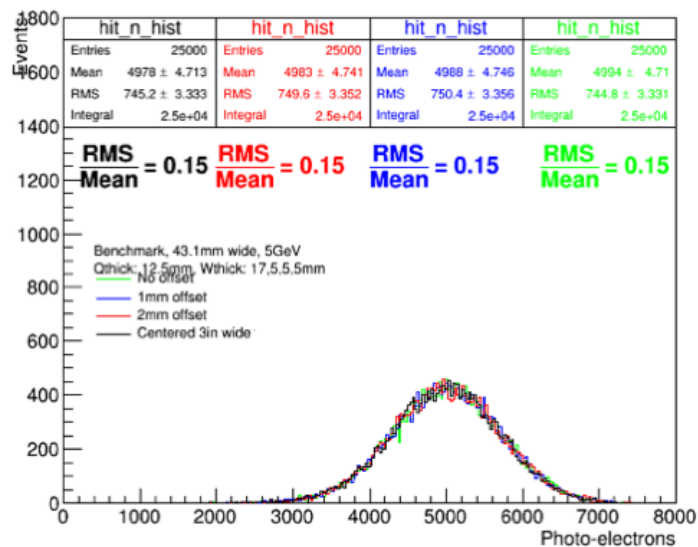

BenchMarking MC Visualization

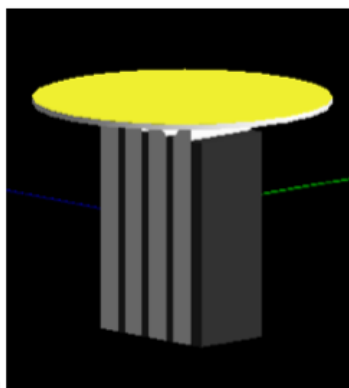

Full Scale MC Vis.

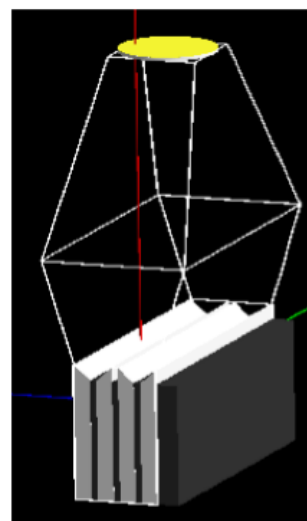

ShowerMax - Config 2

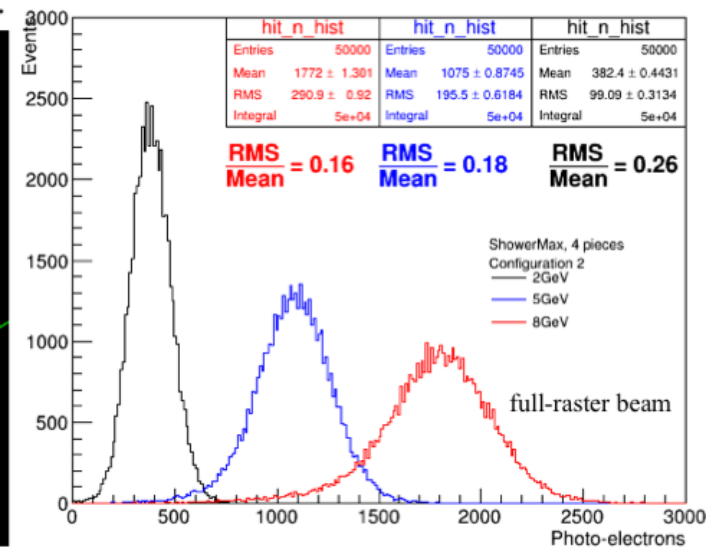

Config #	t_f (mm)	t_q (mm)	t_w (mm)	b (mm)	a (mm)	X_0	R_{mol} (mm)	Leakage (%) 2, 5, 8 GeV from G4 MC	1mm offset Leakage (%)	2mm offset Leakage (%)	Bench. Mean PEs	Bench. RMS / Mean	full- scale Mean PEs	full-scale RMS / Mean
2	17	12.5	5	65	43.2	9.5	11.0	~0 ~0	~0 ~0	~0 ~0	2412 4994	0.19 0.15	382 1075 1772	0.26 0.18 0.16

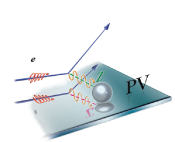

Candidate Design for Stack Prototype: Config #3

Configuration 3 Benchmarking Showermax

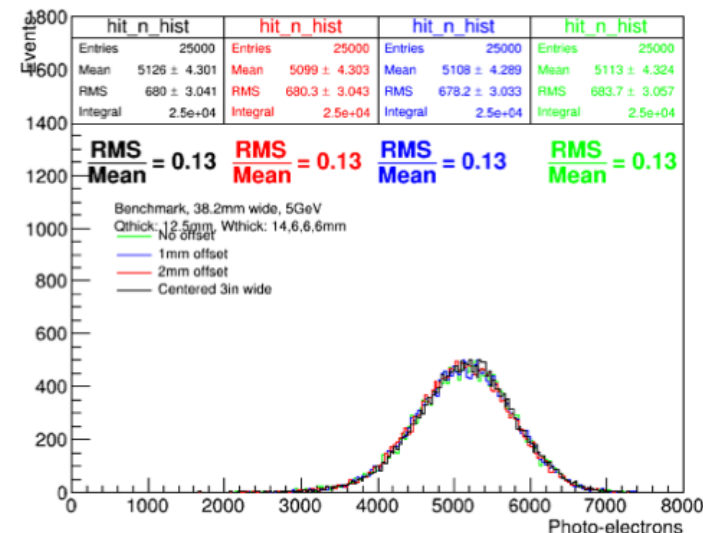

BenchMarking MC Visualization

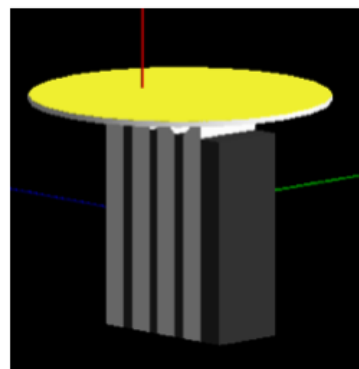

Full Scale MC Vis.

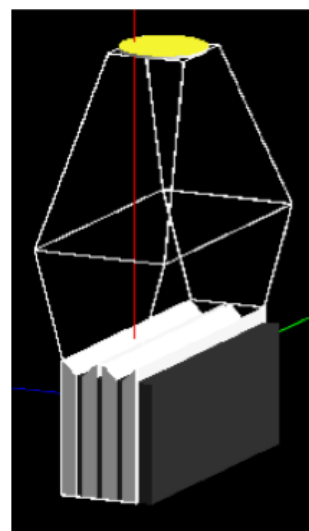

ShowerMax - Config 3

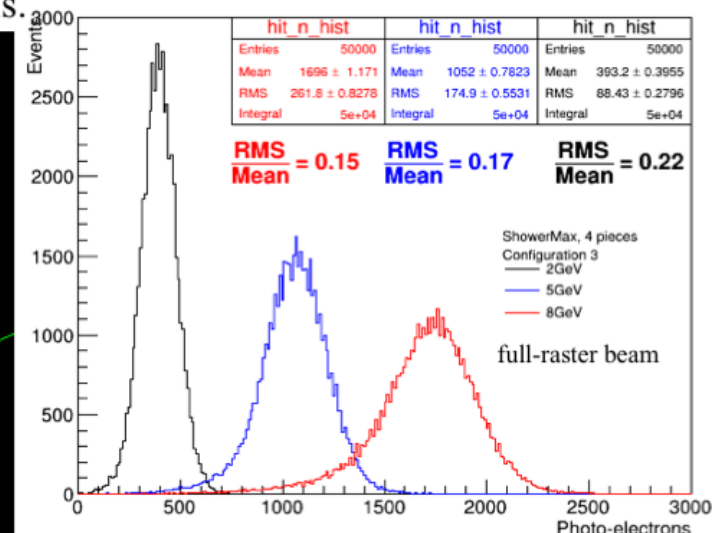

Config #	t_f (mm)	t_q (mm)	t_w (mm)	b (mm)	a (mm)	X_0	R_{mol} (mm)	Leakage (%) 2, 5, 8 GeV from G4 MC	1mm offset Leakage (%)	2mm offset Leakage (%)	Bench. Mean PEs	Bench. RMS / Mean	full- scale Mean PEs	full-scale RMS / Mean
3	14	12.5	6	68	38.2	9.5	11.0	0.5 0.3	0.6 0.4	0.8 0.5	2412 5113	0.19 0.13	393 1052 1696	0.22 0.17 0.15

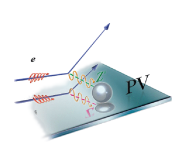

Candidate Design for Stack Prototype: Config #4

Config4 Benchmarking Showermax - 5GeV

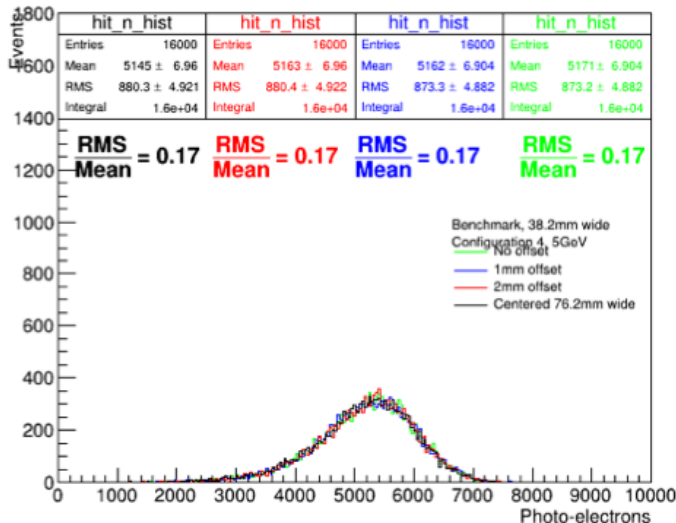

BenchMarking MC Visualization

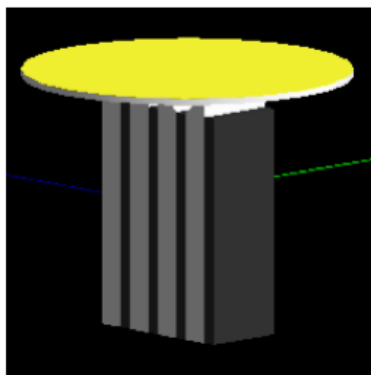

Full Scale MC Vis.

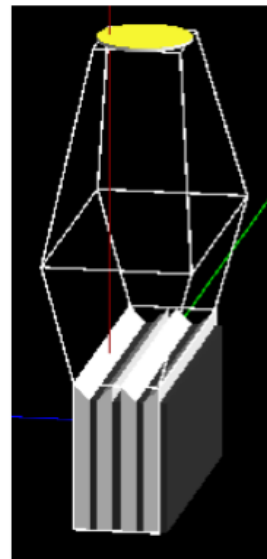

ShowerMax - Config 4

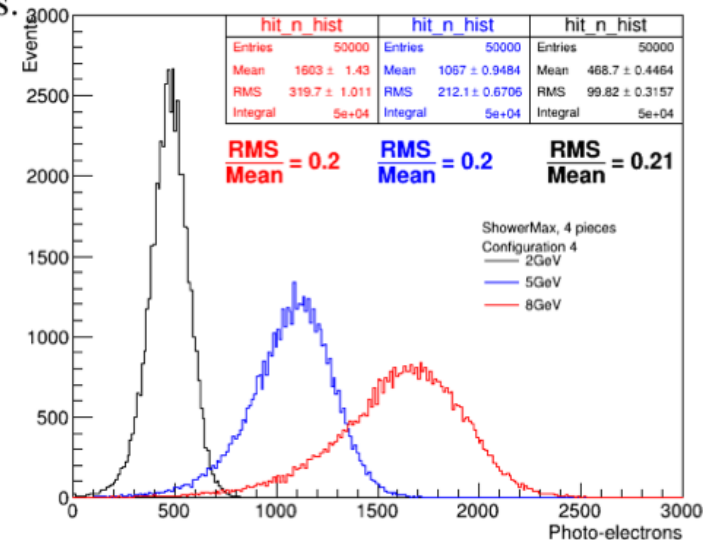

Config #	t_f (mm)	t_a (mm)	t_w (mm)	b (mm)	a (mm)	X_0	R_{mol} (mm)	Leakage (%) 2, 5, 8 GeV from G4 MC	1mm offset Leakage (%)	2mm offset Leakage (%)	Bench. Mean PEs	Bench. RMS / Mean	full- scale Mean PEs	full-scale RMS / Mean
4	6	12.5	6	68	38.2	7.3	11.0	~0 ~0	~0 ~0	~0 ~0	5171	0.17	469 1067 1603	0.21 0.20 0.20

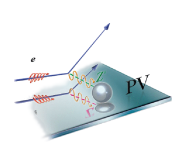

Simulation Results for new Stack Configs

Config #	t_f (mm)	t_q (mm)	t_w (mm)	b (mm)	Max A (mm)	X	Tungsten Weight (N)	Quartz Weight (N)	Total Weight (N)	Moliere R_m (mm)
1A	8	10	8	64	44.59	9.46	156.09	35.57	191.66	11.00
1B	8	6	8	48	61.48	9.33	156.09	35.57	191.66	11.00
4A	6	10	8	64	44.59	8.89	146.33	35.57	181.91	11.11
4B	6	6	6	42	65.73	7.04	117.07	35.57	152.64	11.53

Benchmark - 2GeV				
Config #	RMS/Mean	Leakage (%)	Leakage 2mm offset (%)	Leakage 2° angle (%)
1A	0.17	0	0	-0.1
1B	0.19	0	0	0.2
4A	0.19	0	0	-
4B	0.21	0	0	-

Full Scale ShowerMax – 2GeV			
Config #	RMS	Mean	RMS/Mean
1A	63.36	315.9	0.20
1B	45.46	197.7	0.23
4A**	60.16	300.2	0.20
4B**	39.67	179.3	0.22

Benchmark - 5GeV				
Config #	RMS/Mean	Leakage (%)	Leakage 2mm offset (%)	Leakage 2° angle (%)
1A	0.13	0.04	0.09	-0.4
1B	0.14	0	0	0.2
4A	0.17	0.06	0.3	-
4B	0.19	0	0	-

Full Scale ShowerMax – 5GeV			
Config #	RMS	Mean	RMS/Mean
1A	123.7	768.5	0.16
1B	87.82	473.6	0.19
4A**	126.8	677.4	0.19
4B**	80.61	397.4	0.20

Benchmark – 8GeV				
Config #	RMS/Mean	Leakage (%)	Leakage 2mm offset (%)	Leakage 2° angle (%)
1A	0.12	0	0	-
1B	0.13	0	0	-
4A*	0.18	0	0	-
4B	0.19	0	0	-

Full Scale ShowerMax – 8GeV			
Config #	RMS	Mean	RMS/Mean
1A	183.2	1197	0.15
1B	129.1	732.3	0.18
4A**	187.9	1012	0.19
4B**	118.8	591.3	0.20

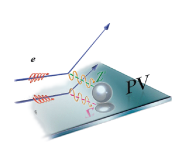

Unity Gain operation with Baseline design?

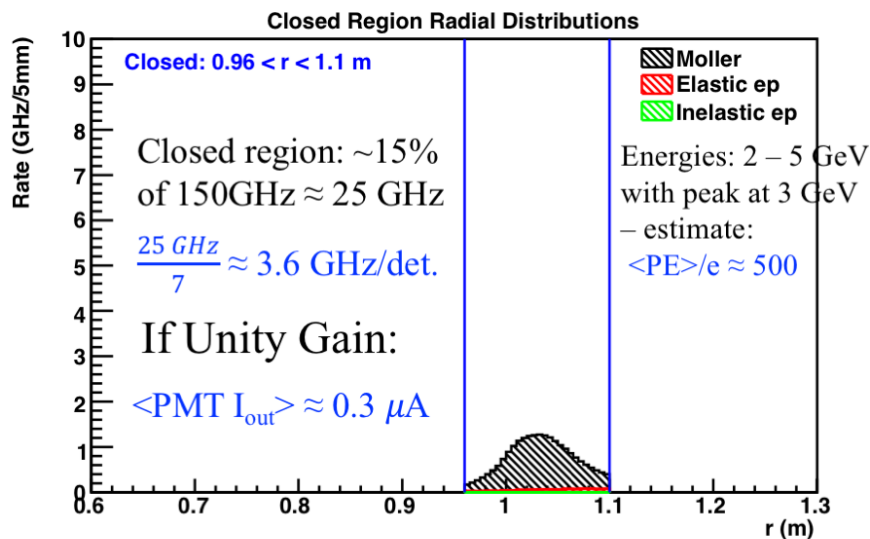
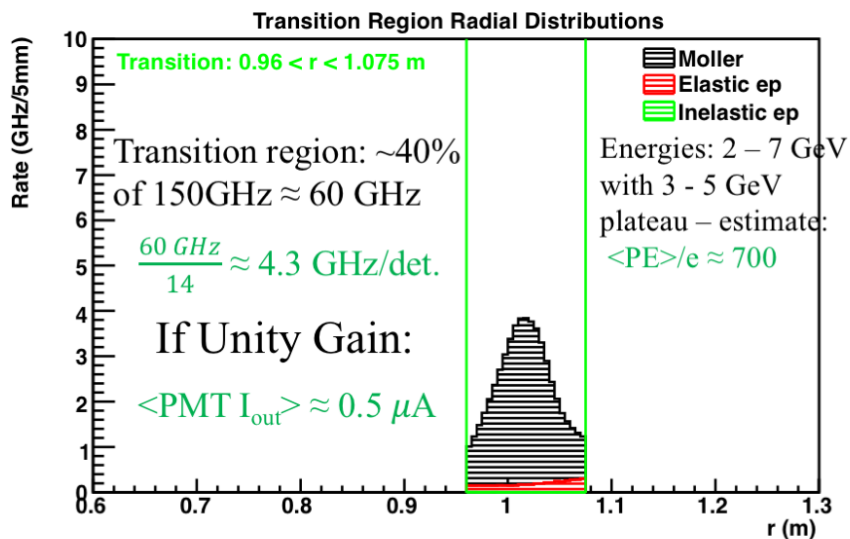
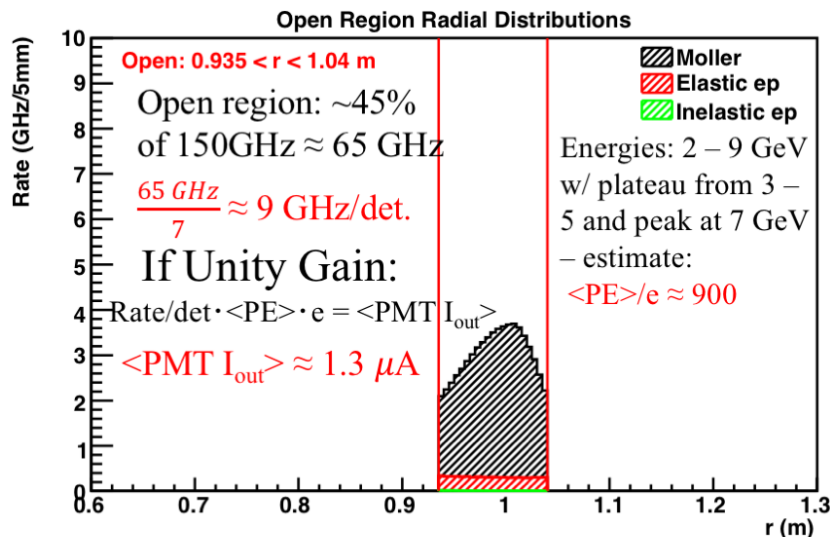
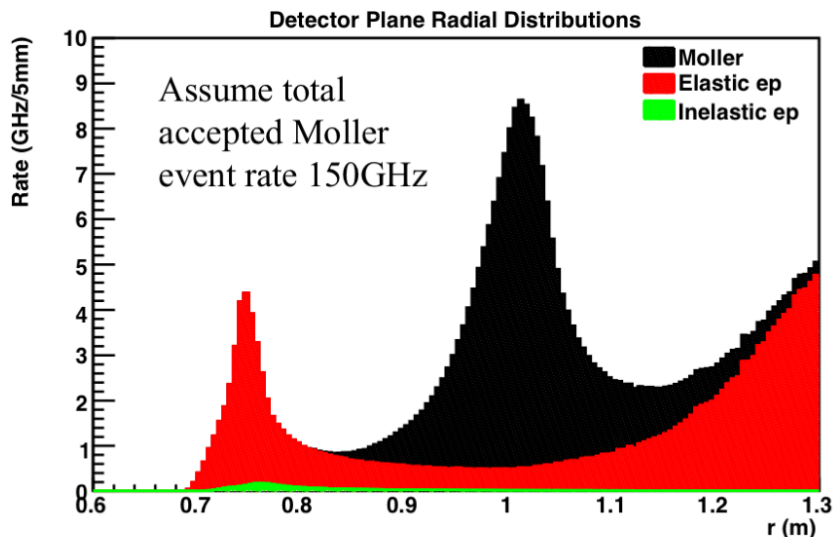

- Could be possible to use conventional 3” pmts with electronic switching between unity gain base (integrating mode) and high gain base (counting mode)

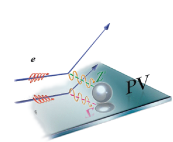

ShowerMax Prototype Construction Timeline

- Feb - Mar 2018: Benchmarking prototype frames fabricated with 3D-printer using ABS plastic (configs 1A and 1B)
- April 2018: Full-scale aluminum frame and light guide cut-outs fabricated at machine shop
- May 2018: Light guide bending and frame assembly at ISU for full-scale configs 1A and 1B
- June 2018: Config 1A full-scale and benchmarking prototype frames and LG delivered to SBU for stack assembly and installation



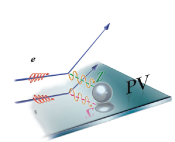

Testbeam Apparatus under construction

- Testbeam stand under construction
- Motion control system in place
- GEM system is operational, analysis software under development

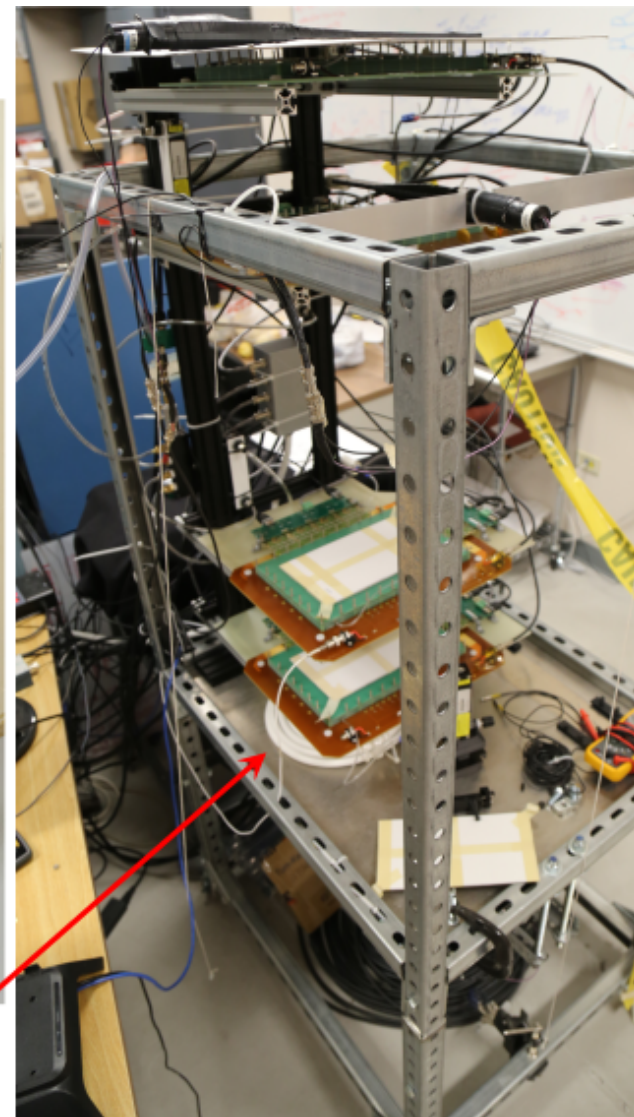
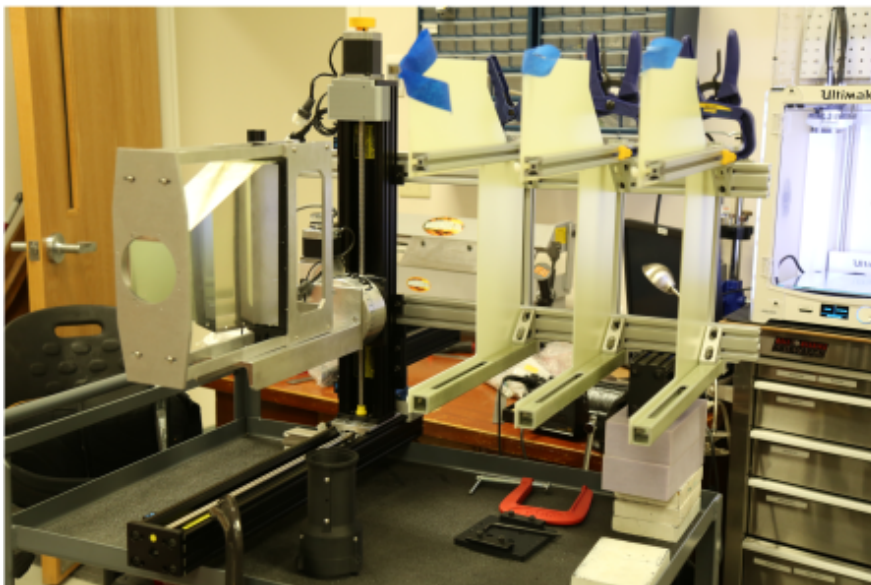

ISU Cosmic stand with 4 GEM chambers