

# MOLLER Task Tracking bluejeans Meeting 2018March28: ISU Tasks

Subsystem	Task	Description	Status	Owner	Relation to Director's Review Report	Estimated Completion Date
<b>Detectors</b>	Radiation hardness of detector components	Investigate which detector components need radiation testing and carry out 50 MRad test	Michael and Dustin devise a plan. Status: Initial list being established	Dustin	Page 12: ``..., all components in the scattered beam envelope should show negligible damage up to 50 MRad.''	May 2019
<b>Detectors</b>	QC plan for main detector quartz	Devise plan to evaluate robustness of main detector quartz (Redundant with ``radiation hardness of detector components'')	Michael and Dustin to devise a plan? Not yet started	Dustin	Page 12: Recommendation: ``Conduct radiation damage tests to at least 50 MRad to qualify fused silica for use in the thin detector	May 2019
<b>Detectors</b>	Shower-Max module mechanical assembly design	This task incorporates the physical design and prototyping of the showerMax detector, as well as the associated mechanical mounting structure	Advanced state of first prototype design, including mechanical assembly	Dustin	Not explicitly mentioned	May 2018

# Radiation Hardness Test plan Update

- RAD testing of mechanical assembly materials and parts (ISU, UM)
  - ❖ Irradiated several light-guide (LG) material samples over a 3 day test run from Mar 22 - 24, 2016 at the Idaho Accelerator Center (IAC) using 8 MeV, 65 mA  $I_{\text{peak}}$ , 4 $\mu$ s pulse width at 250 Hz rep-rate (dose exposure rate was calculated but too high to measure):
    - Measured LG specular reflectivity for 200 – 800 nm at 90, 60, 45, and 30 degrees.
    - No measurable change in reflectivity was detected for  $\gg 50$  MRad exposure
  - ❖ Other assembly materials to test could include Kapton and Tedlar (light tight wrappings) and possibly 3D-printed custom plastic assembly components (Nylon, ABS, PLA, ...) as well as high-density shielding plastics, epoxies, ...
    - Planning for future irradiation tests at IAC —*need guidance on what materials to test and how to quantify or assess their radiation hardness, mechanically or otherwise*
- Main Detector Quartz Robustness (radiation hardness, QA, etc.) (ISU, UM)
  - ❖ Preparations underway to measure quartz optical transparency during irradiation dose study at the IAC:
    - Apparatus developed to make relative transparency measurements between 200 – 800 nm
      - Uses Ocean Optics USB spectrometer, UV-Visible light source, custom holder/stand
    - Energy deposition calculations (dE/dx and brem) underway for 8 MeV beam and 1.5 cm thick quartz—for heating and thermal expansion considerations (do not want to crack quartz)
    - Investigating ability to calibrate and monitor beam dose exposure during study
    - Will have a 1 day IAC test run on April 19 to calibrate dose exposure rates for upcoming studies

# ShowerMax Prototyping and Testbeam Plan Update

- We finalized prototype stack configurations last fall; SBU purchased prototype quartz and tungsten in Nov 2017 (They are now in hand?)
- We finalized full-scale prototype design and sent drawings to machine shop – we are making two complete detectors (configs 1A and 1B) including miro-silver light guides
- We finalized the benchmarking detector design and printed all parts for configs 1A and 1B
- Purchased two 3 inch PMTs to use for prototype testing; should have them by end of May
- Our SLAC testbeam time request was recently approved; we will determine the date next week

# Extra Slides

# Radiation Hardness QA for quartz and other components

## 25 MeV LINAC (Main Hall and Airport)

**RF Frequency:** 2856 MHz (S-Band)

**Energy Range:** ~4~25 MeV (current varies)

**Pulse Width:** ~50ns to 4 micro seconds

**Repetition Rate:** single pulse to 360 Hz

**Ports:** 0 degree, 45 degree and 90 degree (Beam energy resolution ~ 1+/- 15%)

25B Energy vs Current			
Energy (MeV)	0 port (mA)	45 port (mA)	90 port (mA)
23	55	55 @ 3.8uS	46 @ 3.6 uS
20	100	70 @ 4 uS	65 @ 4 uS
16	100	48 @ 3.6 uS	48 @ 3.6 uS
13	80	30 @ 3.3 uS	15 @ 3.3uS
10	60	18 @ 3 uS	7.5 @ 3 uS
9	110	30 @ 4uS	15 @ 4 uS
6	100	60 @ 4 uS	60 @ 4 uS
4	50	20 @ 4 uS	20 @ 4 uS

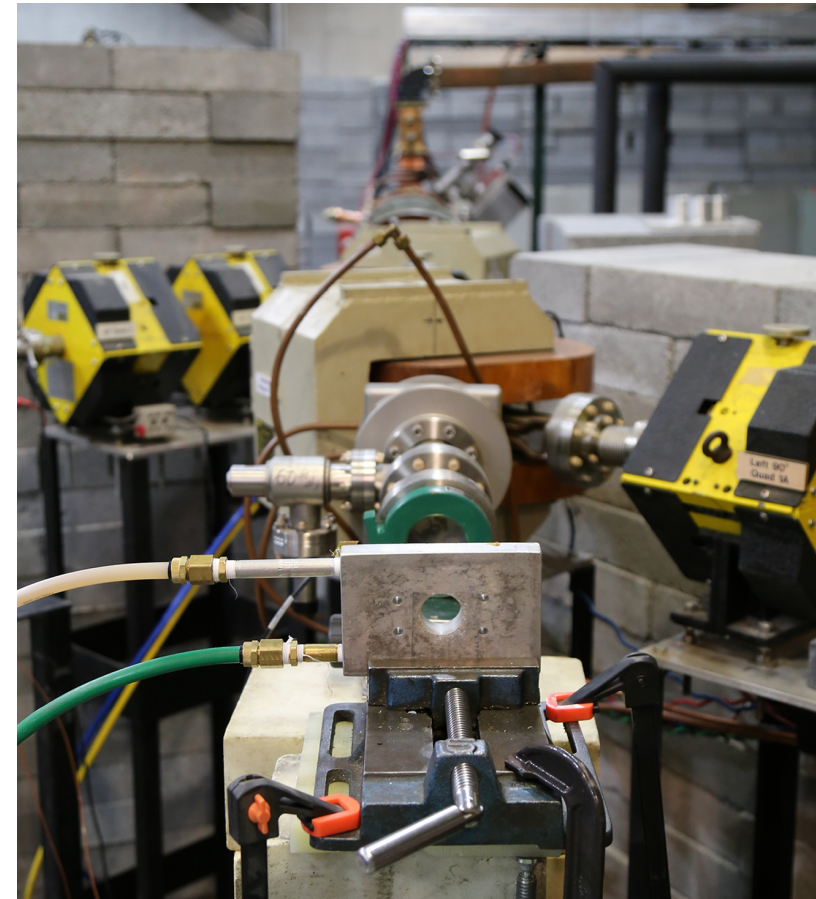
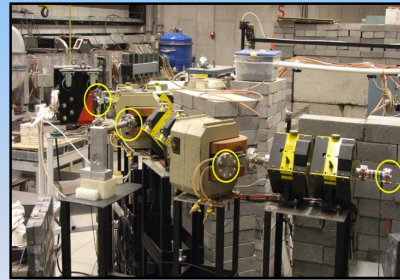

- A key issue is how well can we calibrate dose exposure?
- Another issue is how low can we go in beam current (while still monitoring it)

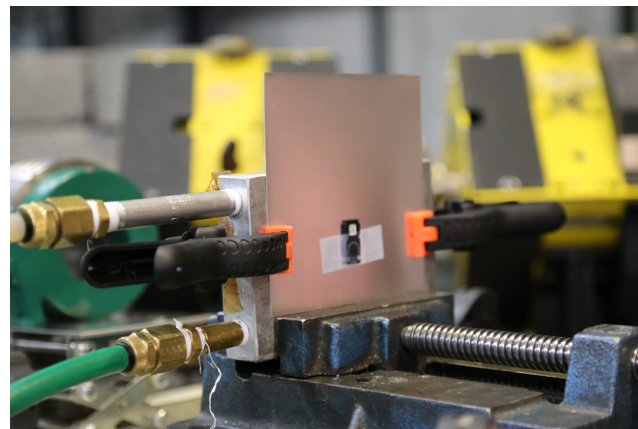

- Planning for a 1 day engineering run late spring or early summer to address these questions.

# Baseline ShowerMax Design and Ring Concept

Open region (original) Baseline Design

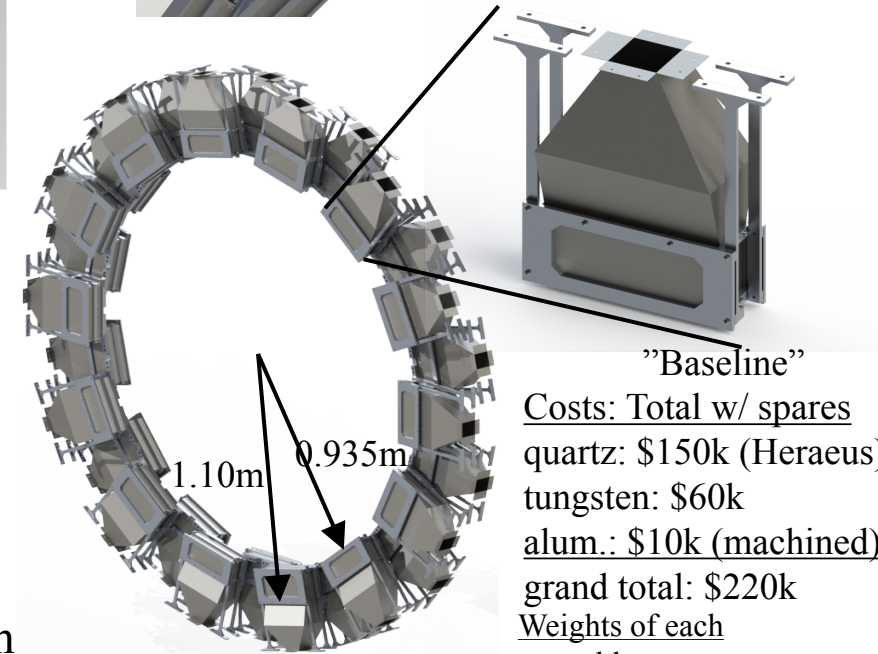
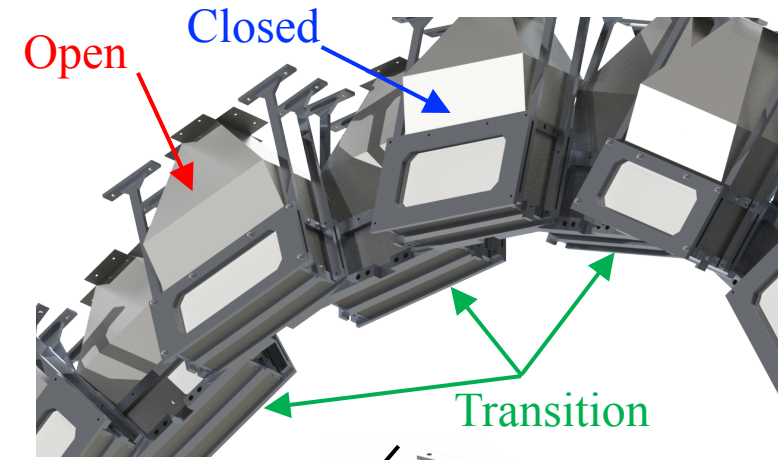
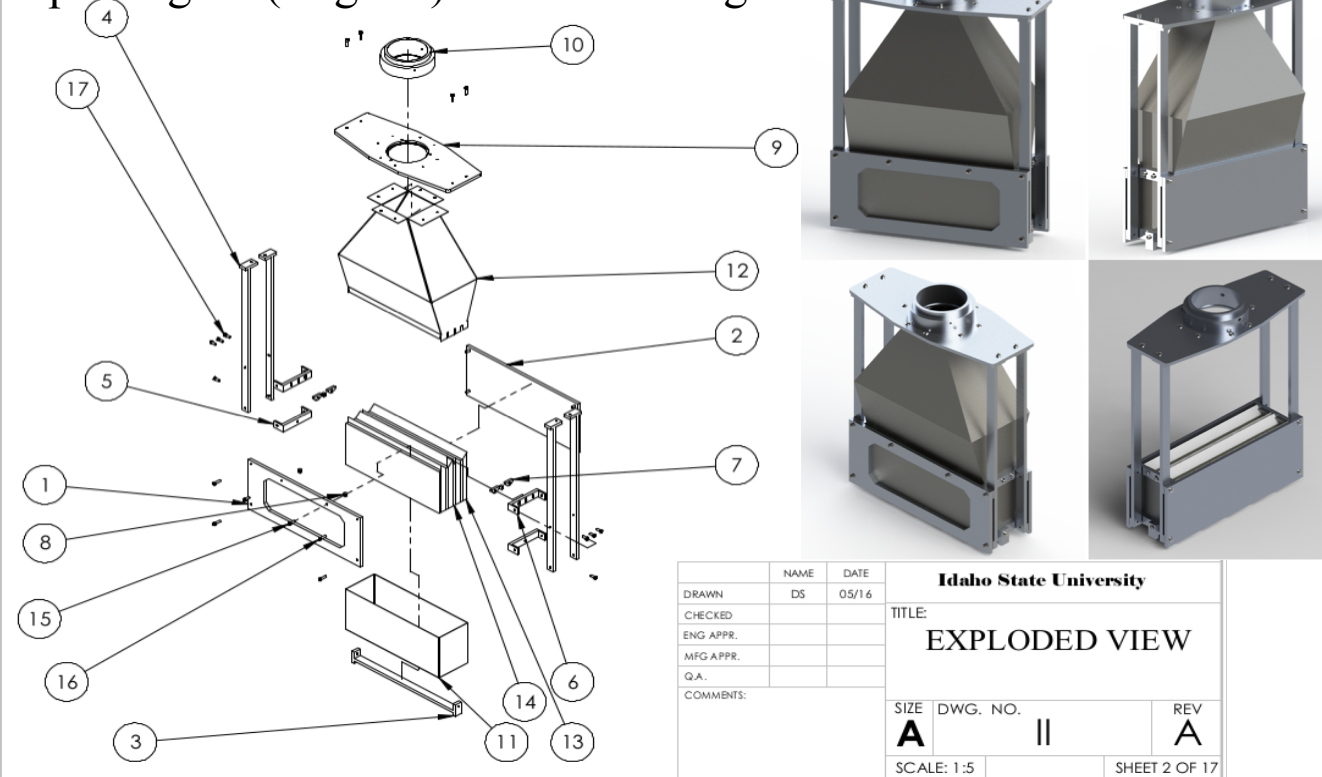

"Baseline"

Costs: Total w/ spares  
 quartz: \$150k (Heraeus)  
 tungsten: \$60k  
 alum.: \$10k (machined)  
 grand total: \$220k  
Weights of each assembly:  
 Open: 39.7 lbs.  
 Transition: 42.5 lbs.  
 Closed: 50.8 lbs.  
 ring weight: 1230 lbs.

- Engineered shop drawings for full-scale prototypes in hand
- **PLANS:** Finalized prototype Stack designs last fall and ordered prototype quartz in Nov 2017, construct in winter/spring 2018 and test in summer/fall using 2 - 10 GeV electron SLAC testbeam
- Shower-max ring design concept: staggered in  $\hat{z}$  with reinforced struts and brackets. 28 detectors in ring: 7 Open, 7 Closed, and 14 Transition

# Quartz and tungsten purchased by SBU in Nov 2017

- For “benchmarking” prototype stack:
  - Quartz: 6 mm (thick) by 86 mm (tall) by 40 mm (wide) --4 pieces (\$975/piece = \$3.9k)
  - Quartz: 10 mm (thick) by 90 mm (tall) by 40 mm (wide) --4 pieces (\$1005/piece = \$4.0k)
  - Tungsten: 6 mm (thick) by 80 mm (tall) by 40 mm (wide) – 4 pieces (\$85/piece = \$340)
  - Tungsten: 8 mm (thick) by 80 mm (tall) by 40 mm (wide) – 4 pieces (\$110/piece = \$440)
  - Tungsten: 2 mm (thick) by 80 mm (tall) by 40 mm (wide) – 4 pieces (\$25/piece = \$100)
- For “full-scale” prototype stack:
  - Quartz: 6 mm (thick) by 111 mm (tall) by 246 mm (wide) -- 4 pieces (~\$1750/piece = \$7.0k)
  - Quartz: 10 mm (thick) by 115 mm (tall) by 246 mm (wide) -- 4 pieces (~\$1940/piece = \$7.8k)
  - Tungsten: 6 mm (thick) by 105 mm (tall) by 246 mm (wide) – 4 pieces (\$600/piece = \$2.5k)
  - Tungsten: 8 mm (thick) by 105 mm (tall) by 246 mm (wide) – 4 pieces (\$820/piece = \$3.2k)
  - Tungsten: 2 mm (thick) by 105 mm (tall) by 246 mm (wide) – 4 pieces (\$200/piece = \$0.8k)

Purchasing these pieces allows for Configs 1, 3, and 4 (A and B) to be tested

Total quartz: \$25k, total tungsten: \$7.5k: Total = \$32.5k

- Going with 6mm tiles allows construction of two benchmarking and two full-scale prototype sets
- Building two sets of prototypes will allow for more efficient testing during both SLAC testbeam and cosmic tests at SBU and ISU. We can each build a different configuration to test

# Updated Full-Scale Prototype (1A) for Beamtest

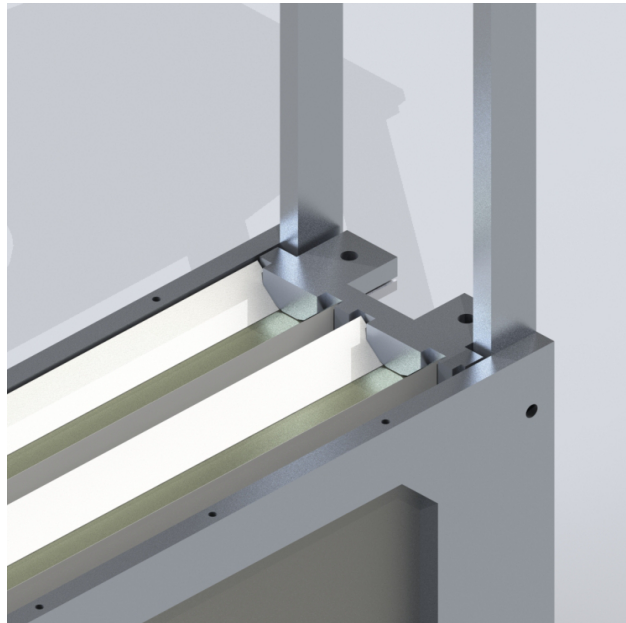
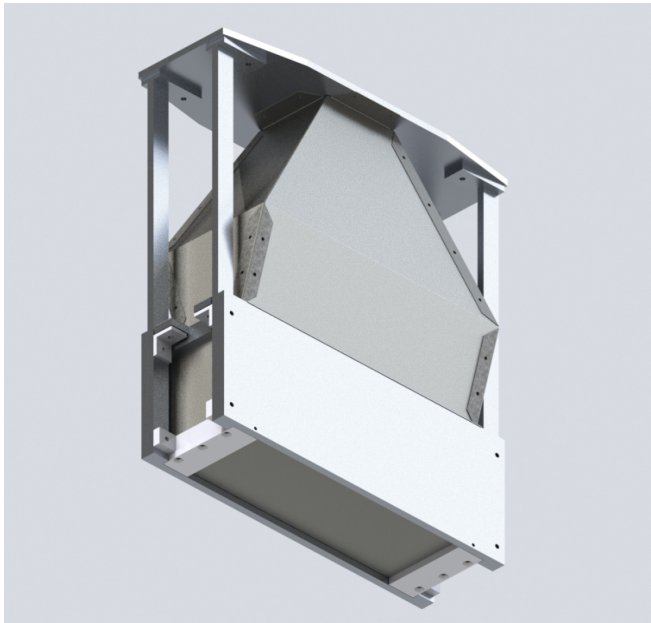
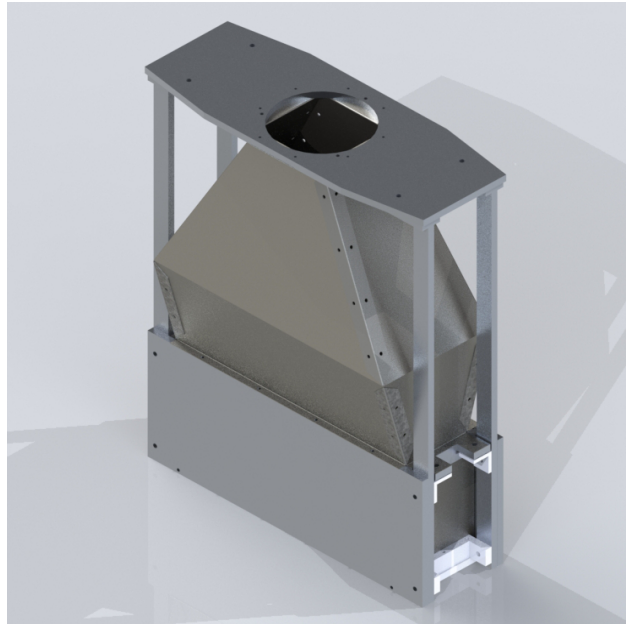
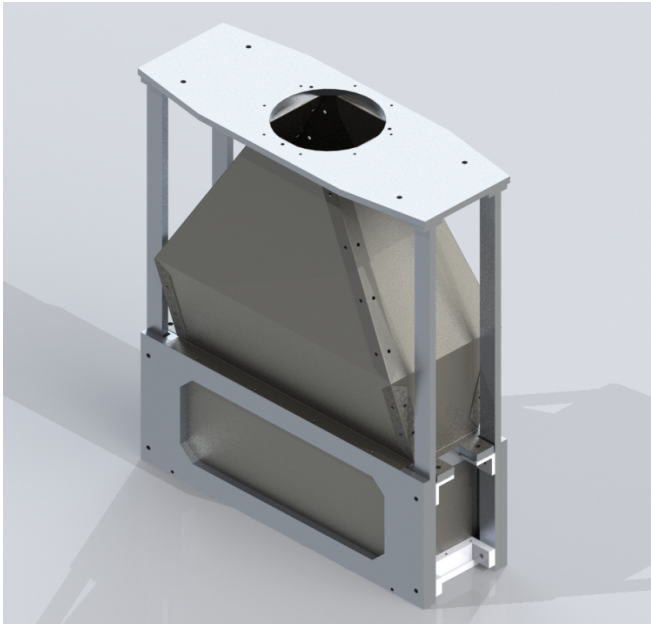

UNLESS OTHERWISE SPECIFIED:		NAME	DATE	Moller Collaboration
DIMENSIONS ARE IN INCHES		DRAWN	DKS	1/16/18
TOLERANCES:		CHECKED		TITLE:
FRACTIONAL ±		ENG APPR.		Light Guide
ANGULAR: MACH ± BEND ±		MFG APPR.		
TWO PLACE DECIMAL ±		Q.A.		
THREE PLACE DECIMAL ±		COMMENTS:		
INTERPRET GEOMETRIC TOLERANCING PER:				
MATERIAL:				
SIZE	DWG. NO.	REV		
<b>A</b>	<b>I</b>	<b>0</b>		
SCALE: 1:10	WEIGHT:	SHEET 1 OF 9		

ITEM NO.	PART	MATERIAL	QTY.
1	Light Guide - Back	0.020 ANODIUM MICRO-SILVER REFLECTIVE ALUMINIUM SHEET	1
2	Light Guide - Front	0.020 ANODIUM MICRO-SILVER REFLECTIVE ALUMINIUM SHEET	1
3	Long Flap	0.020 ANODIUM MICRO-SILVER REFLECTIVE ALUMINIUM SHEET	2
4	Short Flap	0.020 ANODIUM MICRO-SILVER REFLECTIVE ALUMINIUM SHEET	4
5	Suitcase	0.020 ANODIUM MICRO-SILVER REFLECTIVE ALUMINIUM SHEET	2

UNLESS OTHERWISE SPECIFIED:		NAME	DATE	Moller Collaboration
DIMENSIONS ARE IN INCHES		DRAWN	DKS	1/16/18
TOLERANCES:		CHECKED		TITLE:
FRACTIONAL ±		ENG APPR.		Exploded View
ANGULAR: MACH ± BEND ±		MFG APPR.		
TWO PLACE DECIMAL ±		Q.A.		
THREE PLACE DECIMAL ±		COMMENTS:		
INTERPRET GEOMETRIC TOLERANCING PER:				
MATERIAL:				
SIZE	DWG. NO.	REV		
<b>A</b>	<b>II</b>	<b>0</b>		
SCALE: 1:10	WEIGHT:	SHEET 2 OF 9		

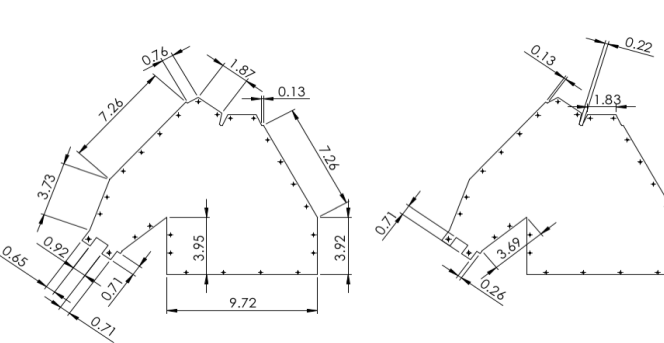

**Building two full-scale prototypes: Drawings for Configs 1A and 1B sent to the shop, including light guide cut-outs which will be bent in April/May**



# ShowerMax Benchmarking Prototype Concept

- Concept allows stack to be assembled and beam-tested one piece at a time for detailed benchmarking study
- Fabricated with 3D printed ABS plastic

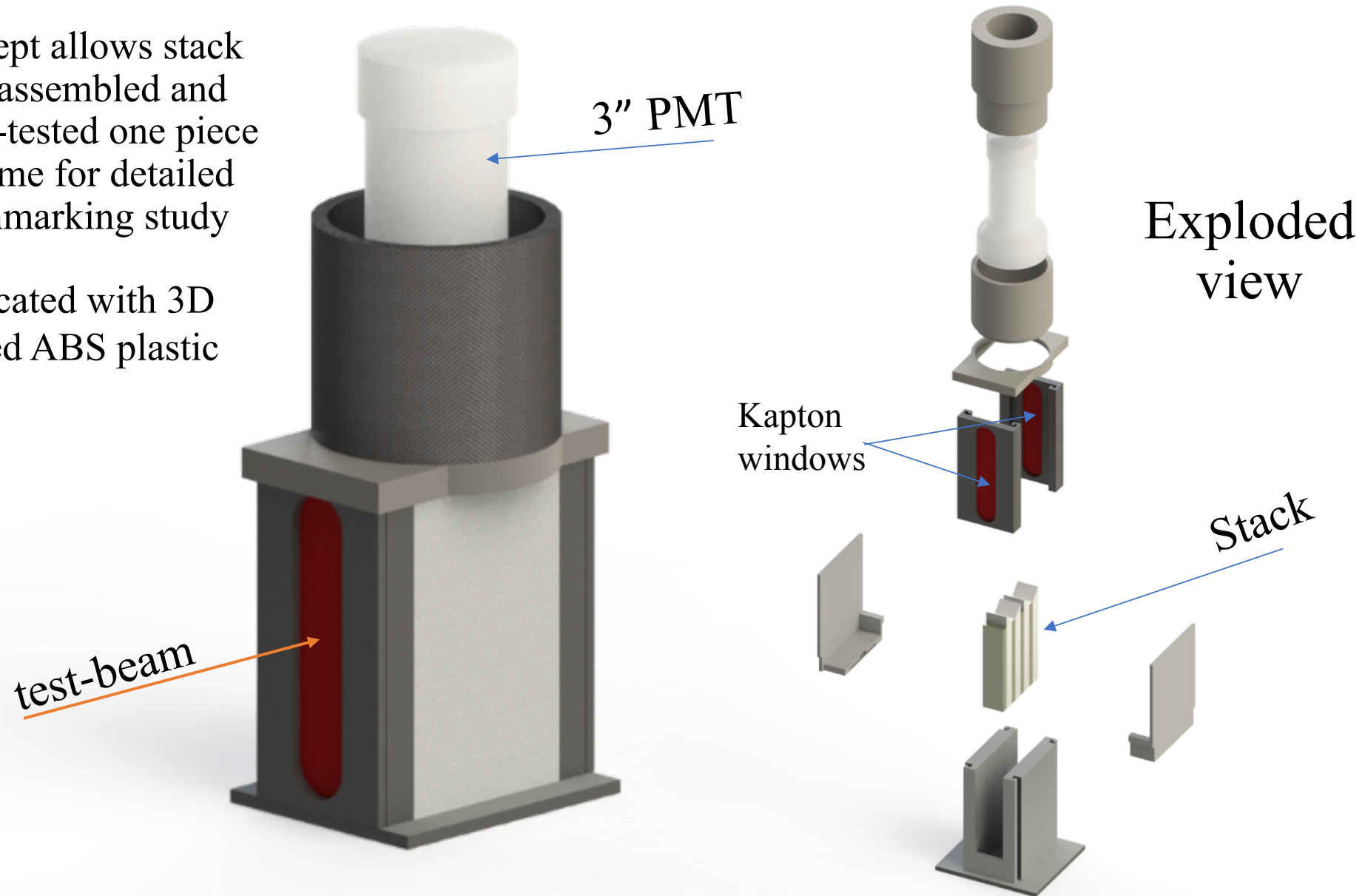

**Config #1** (original baseline) benchmarking Prototype