

Shower-max Update

Dustin McNulty
Idaho State University
mcnulty@jlab.org

May 15, 2019

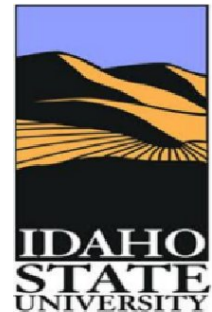
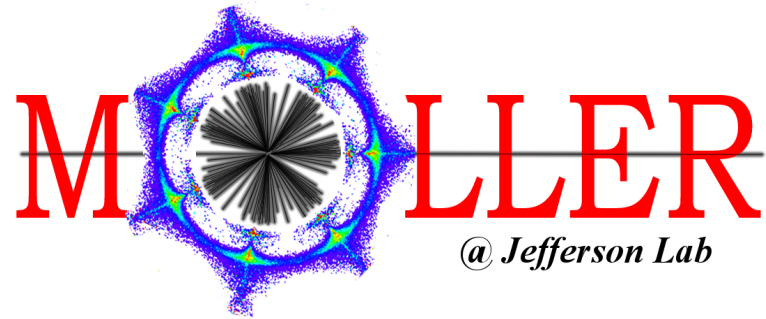

Shower-max Update

Outline

- Review baseline design and ring concept
- Prototypes constructed for testbeam
- Some results from Testbeam
- Summary and Future Work

Shower-max Motivation & Requirements

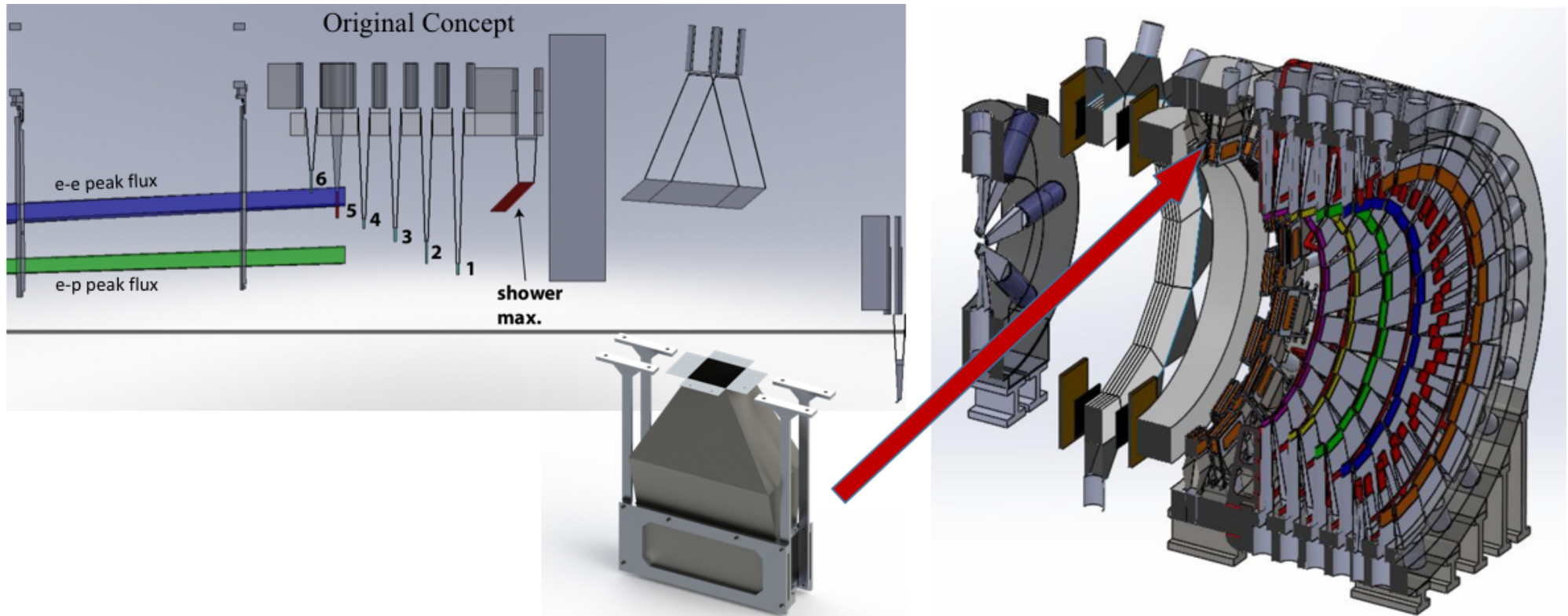

- Provides additional measurement of e-e ring integrated flux
- Weights flux by energy \Rightarrow less sensitive to low energy and hadronic backgrounds
- Will also operate in tracking mode and may give additional handle on background (pion) identification – could give MIP-like signal with removeable filters
- Should have good resolution over full energy range ($\frac{\sigma}{\langle n \rangle} \lesssim 25\%$), long term stability and be radiation hard

Baseline ShowerMax Design and Ring Concept

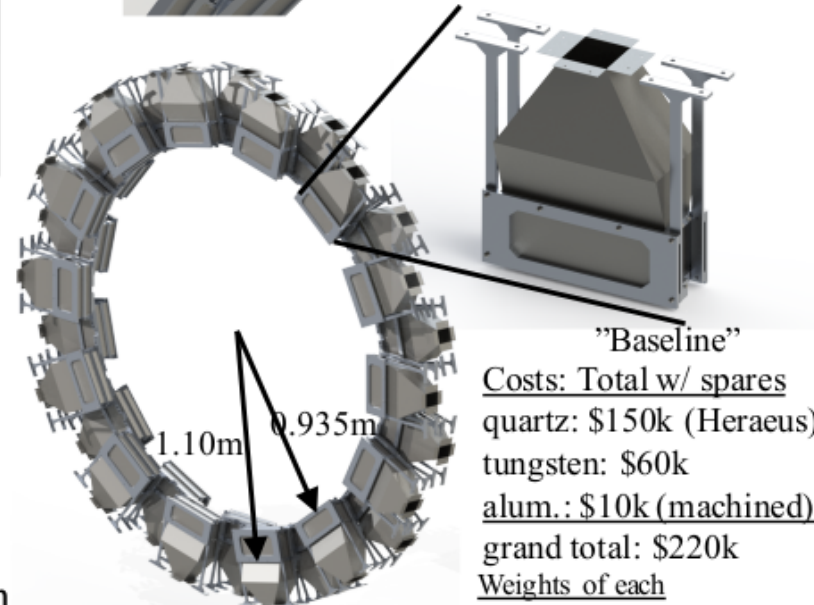
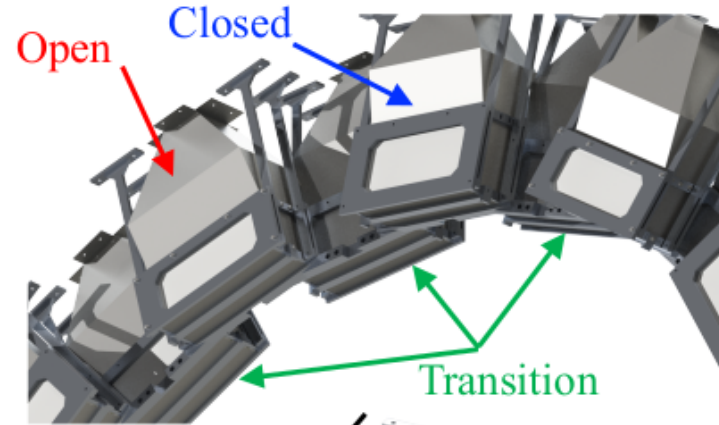
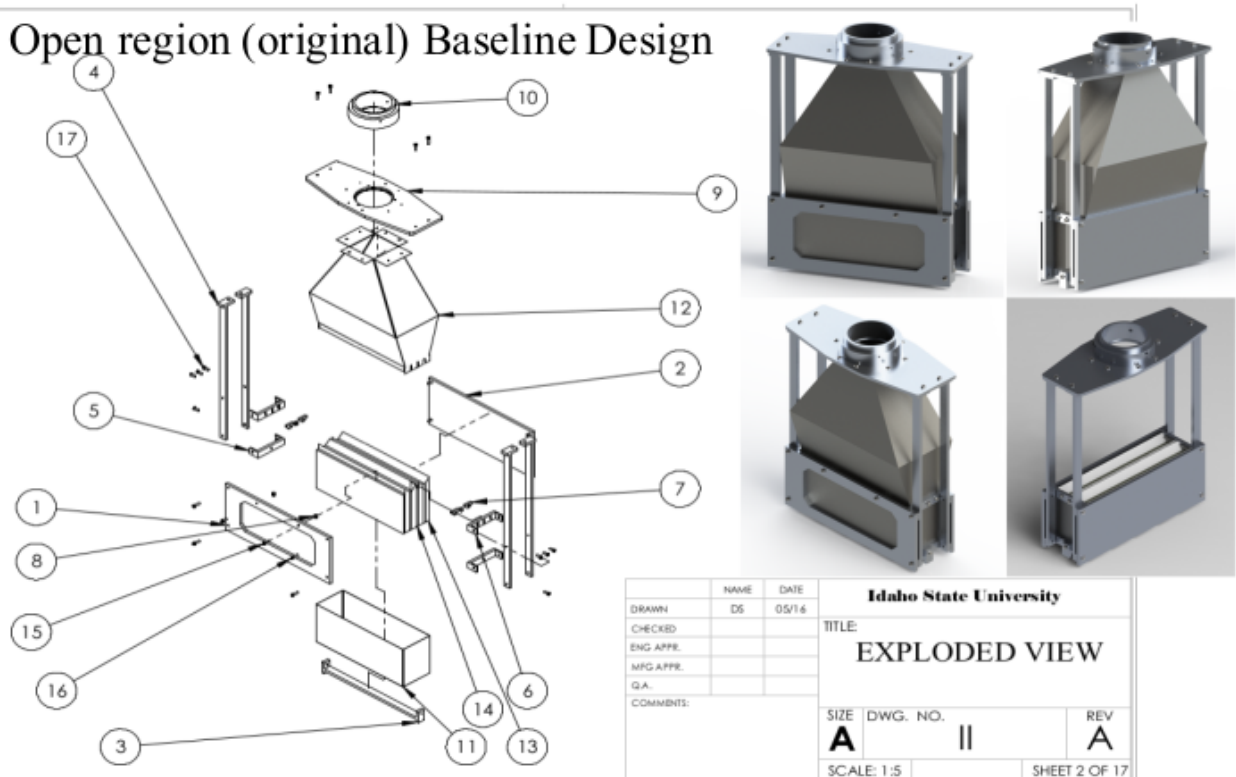

- Engineered shop drawings for full-scale prototypes in hand
- **PLANS**: Finalized prototype Stack designs last fall and ordered prototype quartz in Nov 2017, construct in winter/spring 2018 and test in summer/fall using 2 - 10 GeV electron SLAC testbeam
- Shower-max ring design concept: staggered in \hat{z} with reinforced struts and brackets. 28 detectors in ring: 7 Open, 7 Closed, and 14 Transition

"Baseline"
 Costs: Total w/ spares
 quartz: \$150k (Heraeus)
 tungsten: \$60k
 alum.: \$10k (mached)
 grand total: \$220k
Weights of each assembly:
 Open: 39.7 lbs.
 Transition: 42.5 lbs.
 Closed: 50.8 lbs.
 ring weight: 1230 lbs.

Shower-max phi-segmentation, rates and energies

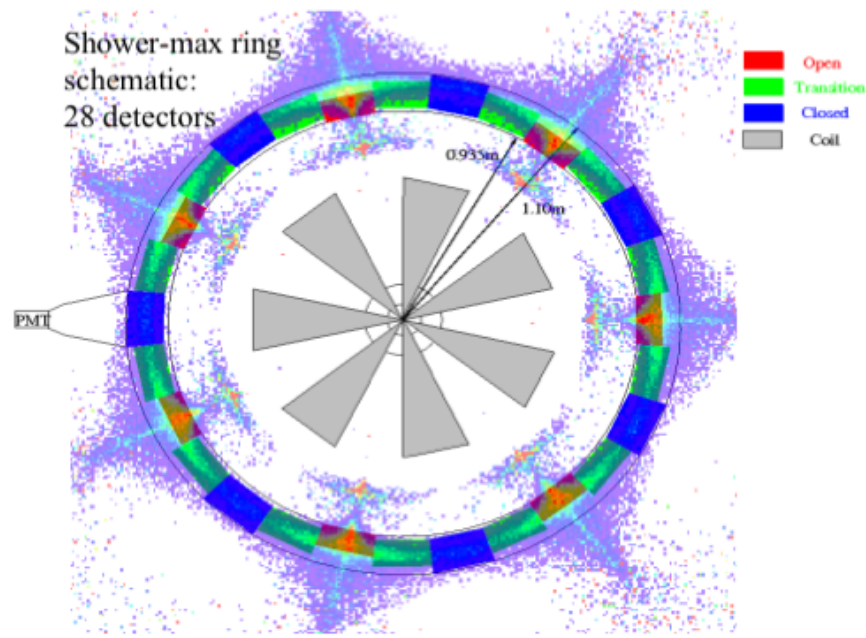
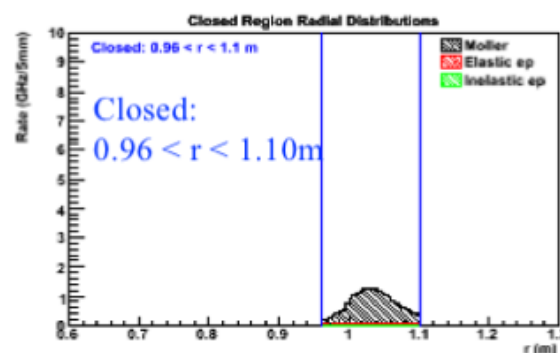
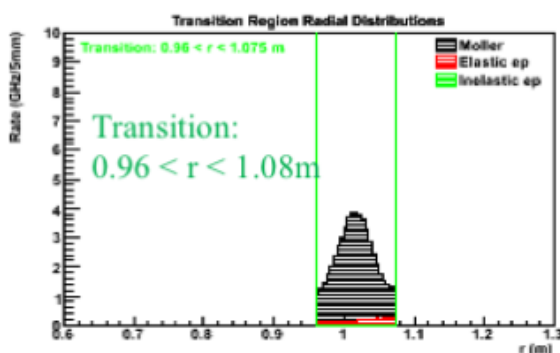
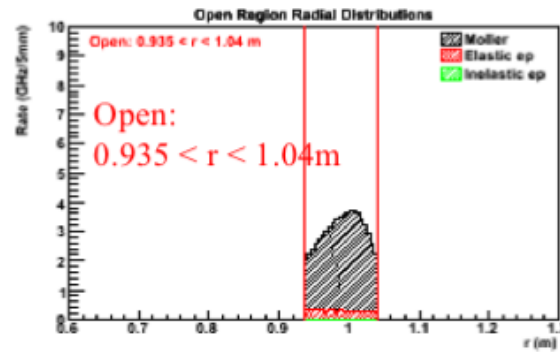
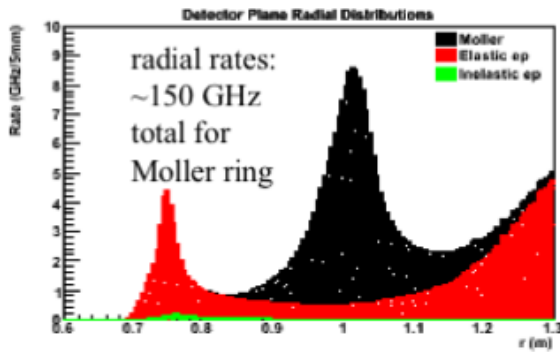

- Large range of rates and energies for different phi-region detectors:
 - Open ~9 GHz/det; 2 - 9 GeV, peak at 7 GeV...
 - Closed ~3.5 GHz/det; 2 - 5 GeV, peak at ~3 GeV
 - Transition ~4.5 GHz/det; 2 - 7 GeV, 3 - 5 GeV plateau

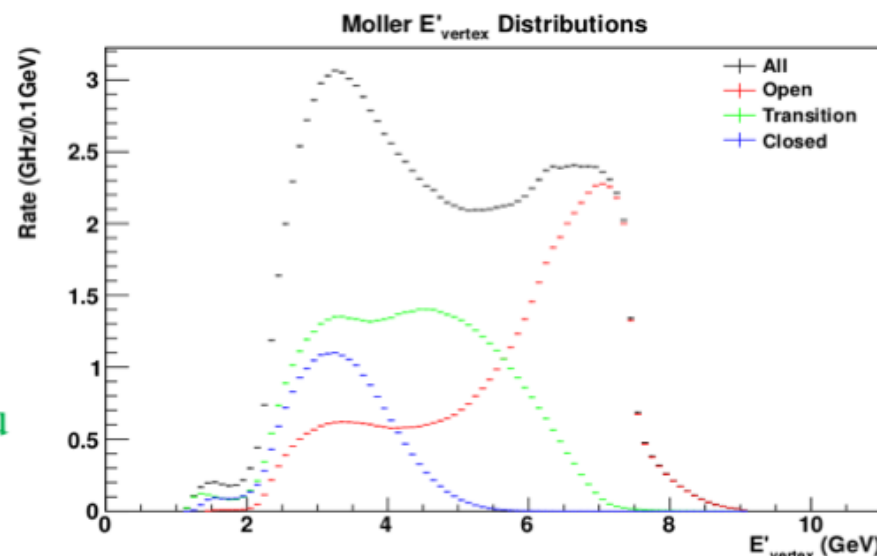

Baseline Design Stack and Light Guide Concepts

- Detector concept uses a layered “stack” of tungsten and fused silica (quartz) to induce EM showering and produce Cherenkov light
- “Baseline” design developed using GEANT4 optical MC simulation:
 - Current design uses a **4-layer stack** with **8 mm tungsten** and **10 mm quartz** pieces
 - Cherenkov light directed to **3 inch PMT** using **air-core, aluminum light guide**

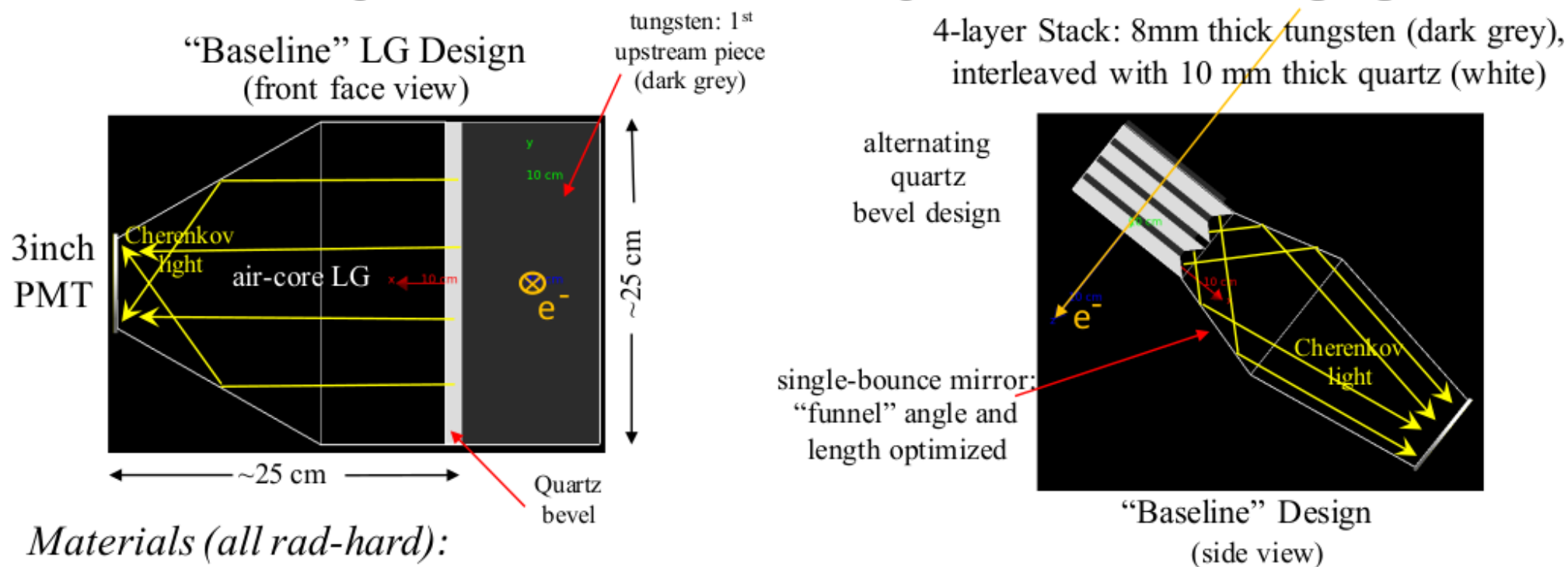

Materials (all rad-hard):

- Tungsten is high purity (99.95%) and quartz is optically polished Spectrosil 2000
- Light guides are aluminum specular reflectors (Miro-silver 27, Anolux, or al. mylar, ...)
- Total radiation length: $9.1 X_0$ tungsten + $0.4 X_0$ quartz = $9.5 X_0$

Full-Scale Prototype (1A) for Testbeam

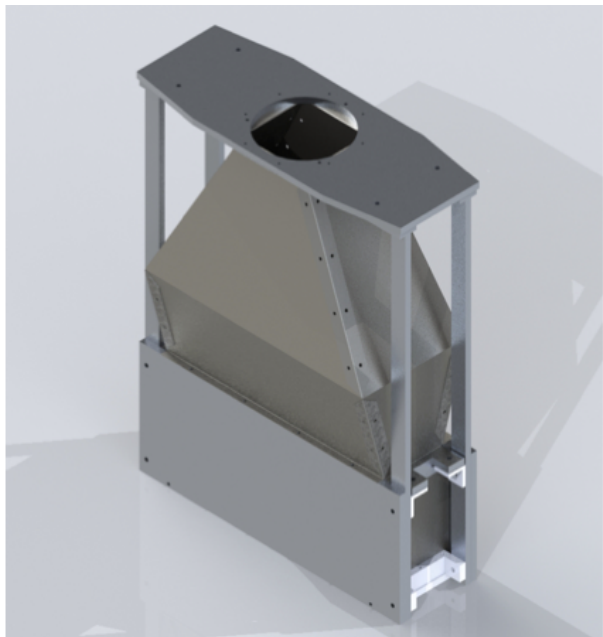
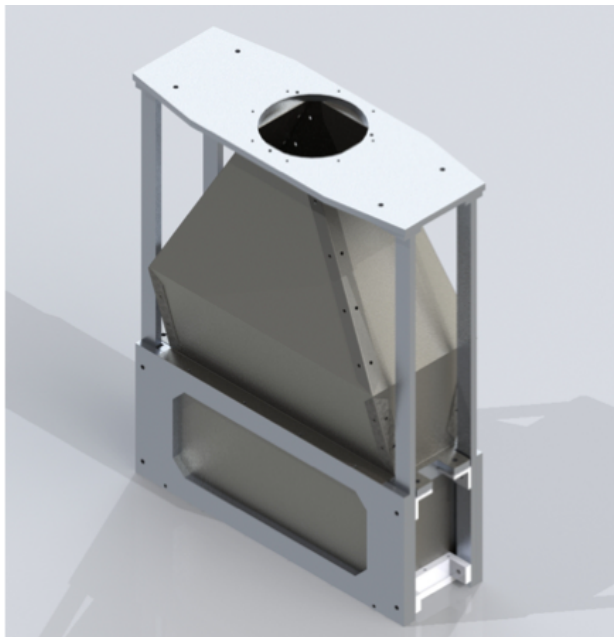

| | | | | |
|--------------------------------------|-----------|------|----------------------|---------------------------------|
| UNLESS OTHERWISE SPECIFIED: | NAME | DATE | Moller Collaboration | |
| DIMENSIONS ARE IN INCHES | DRAWN | DKS | 1/14/18 | TITLE |
| TOLERANCES: | CHECKED | | | Light Guide |
| FRACTIONAL ± | END APPR. | | | SIZE DWG. NO. REV |
| ANGULAR: MACH ± BEND ± | MFG APPR. | | | A I 0 |
| TWO PLACE DECIMAL ± | Q.A. | | | SCALE: 1:10WEIGHT: SHEET 1 OF 9 |
| THREE PLACE DECIMAL ± | COMMENTS: | | | |
| INTERPRET GEOMETRIC TOLERANCING PER: | | | | |
| MATERIAL: | | | | |

| ITEM NO. | PART | MATERIAL | QTY. |
|----------|---------------------|---|------|
| 1 | Light Guide - Back | 0.001 ANODIUM MIRROR SILVER REFLECTIVE ALUMINUM SHEET | 1 |
| 2 | Light Guide - Front | 0.001 ANODIUM MIRROR SILVER REFLECTIVE ALUMINUM SHEET | 1 |
| 3 | Long Flap | 0.001 ANODIUM MIRROR SILVER REFLECTIVE ALUMINUM SHEET | 2 |
| 4 | Short Flap | 0.001 ANODIUM MIRROR SILVER REFLECTIVE ALUMINUM SHEET | 4 |
| 5 | Suitcase | 0.001 ANODIUM MIRROR SILVER REFLECTIVE ALUMINUM SHEET | 2 |

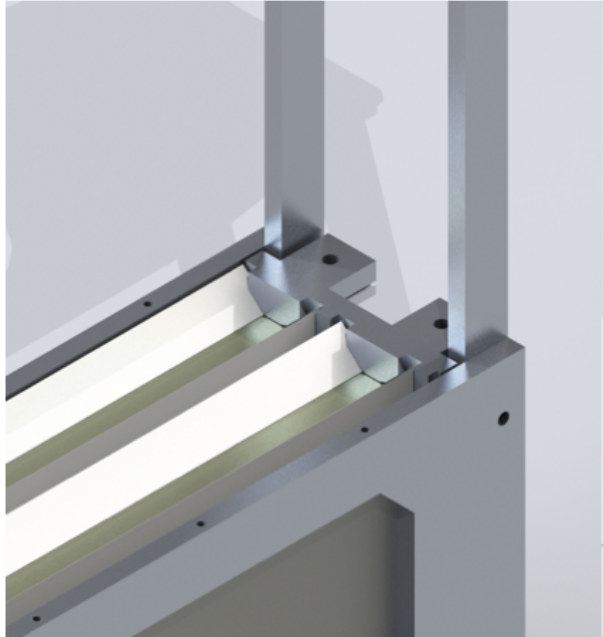
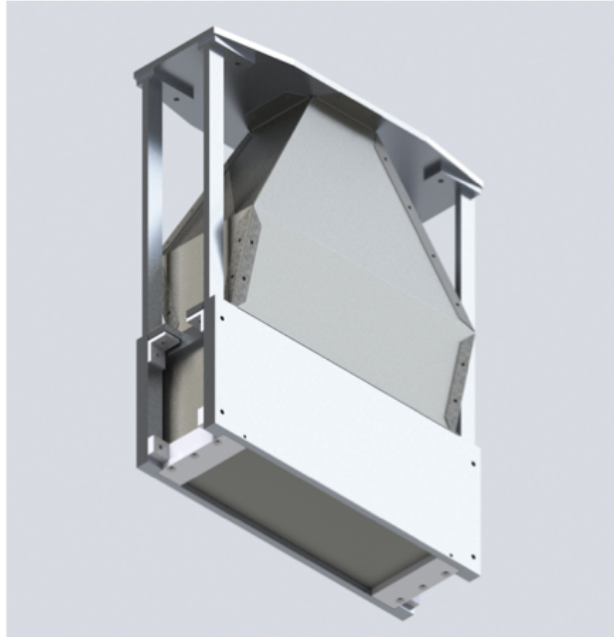

| | | | | |
|--------------------------------------|-----------|------|----------------------|---------------------------------|
| UNLESS OTHERWISE SPECIFIED: | NAME | DATE | Moller Collaboration | |
| DIMENSIONS ARE IN INCHES | DRAWN | DKS | 1/14/18 | TITLE |
| TOLERANCES: | CHECKED | | | Exploded View |
| FRACTIONAL ± | END APPR. | | | SIZE DWG. NO. REV |
| ANGULAR: MACH ± BEND ± | MFG APPR. | | | A II 0 |
| TWO PLACE DECIMAL ± | Q.A. | | | SCALE: 1:10WEIGHT: SHEET 2 OF 9 |
| THREE PLACE DECIMAL ± | COMMENTS: | | | |
| INTERPRET GEOMETRIC TOLERANCING PER: | | | | |
| MATERIAL: | | | | |

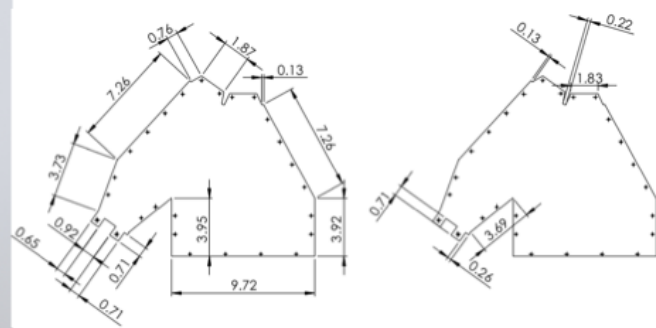

T-577: SLAC Testbeam, Dec 6 – 12, 2018

- Tested ShowerMax full-scale and benchmarking detectors and new ring5 thin detector designs
- Used 3, 5.5 and 8 GeV electrons with multiplicity of a Poisson distribution with $\mu \approx 1$
- Overall beam rate only 5 Hz (parasitic from LCLS beam) with $\sim 1/3$ of those being single e^-

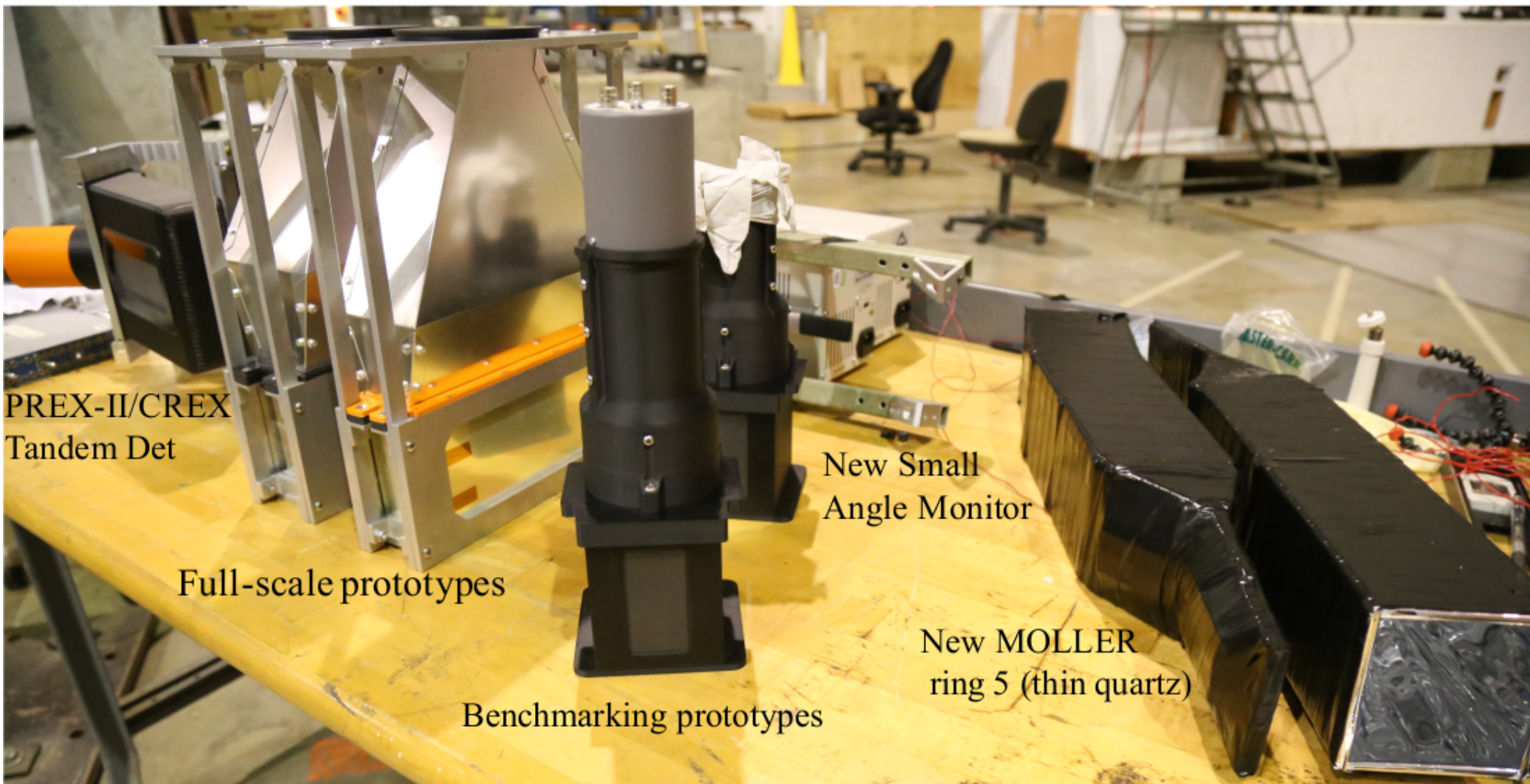

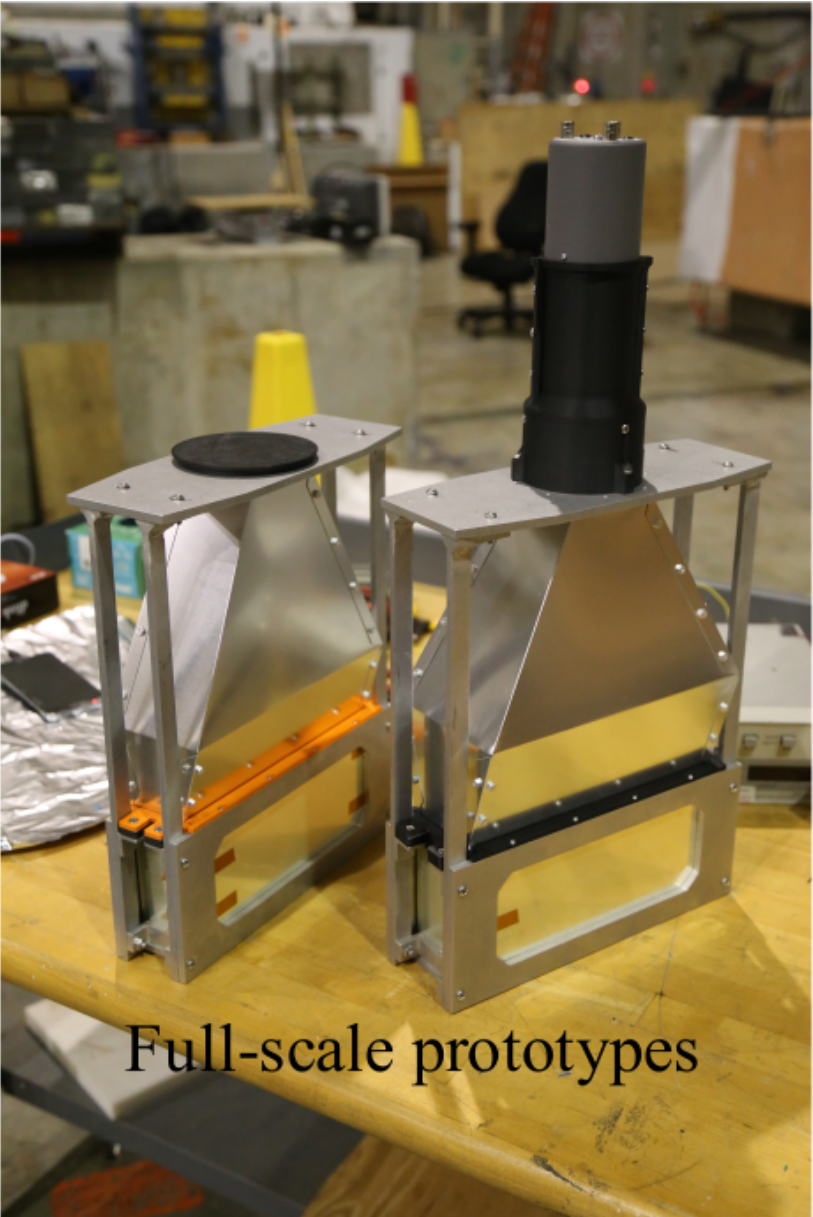

Full-scale prototypes

T-577: SLAC Testbeam Setup for Full-Scale ShowerMax

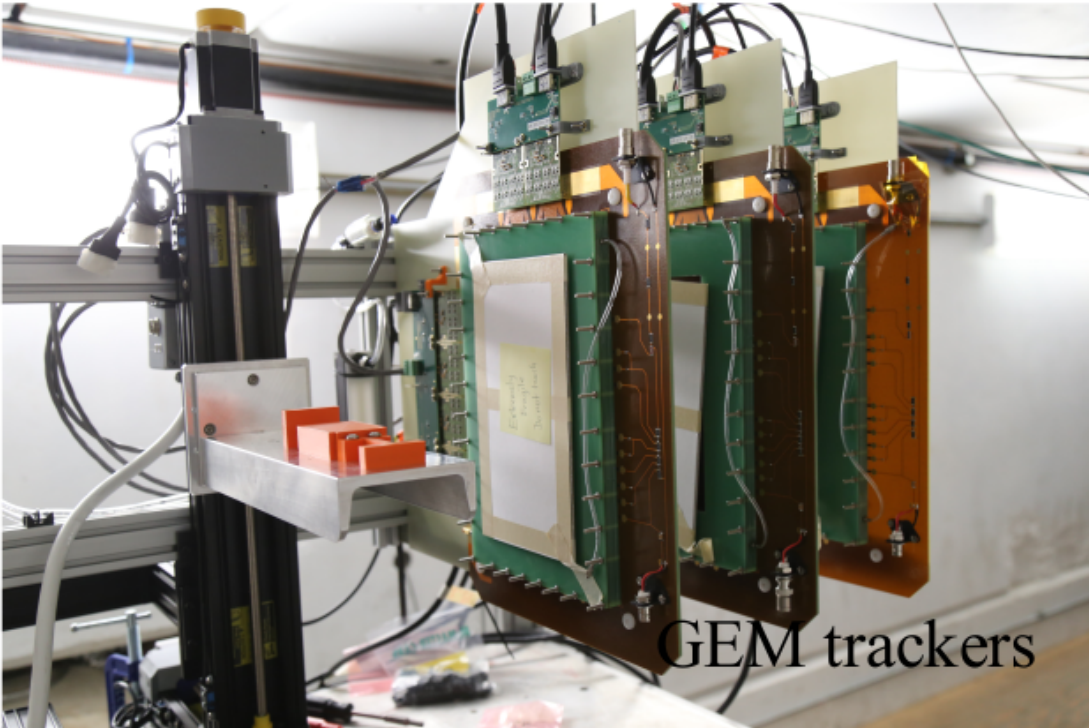
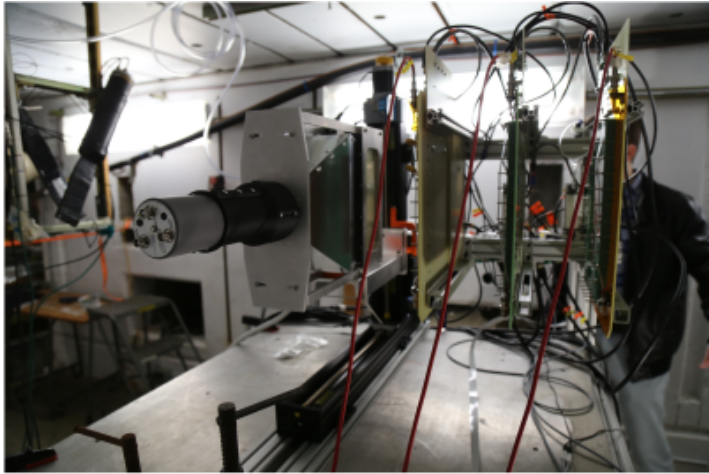

GEM trackers

T-577: SLAC Testbeam Setup: Benchmarking ShowerMax

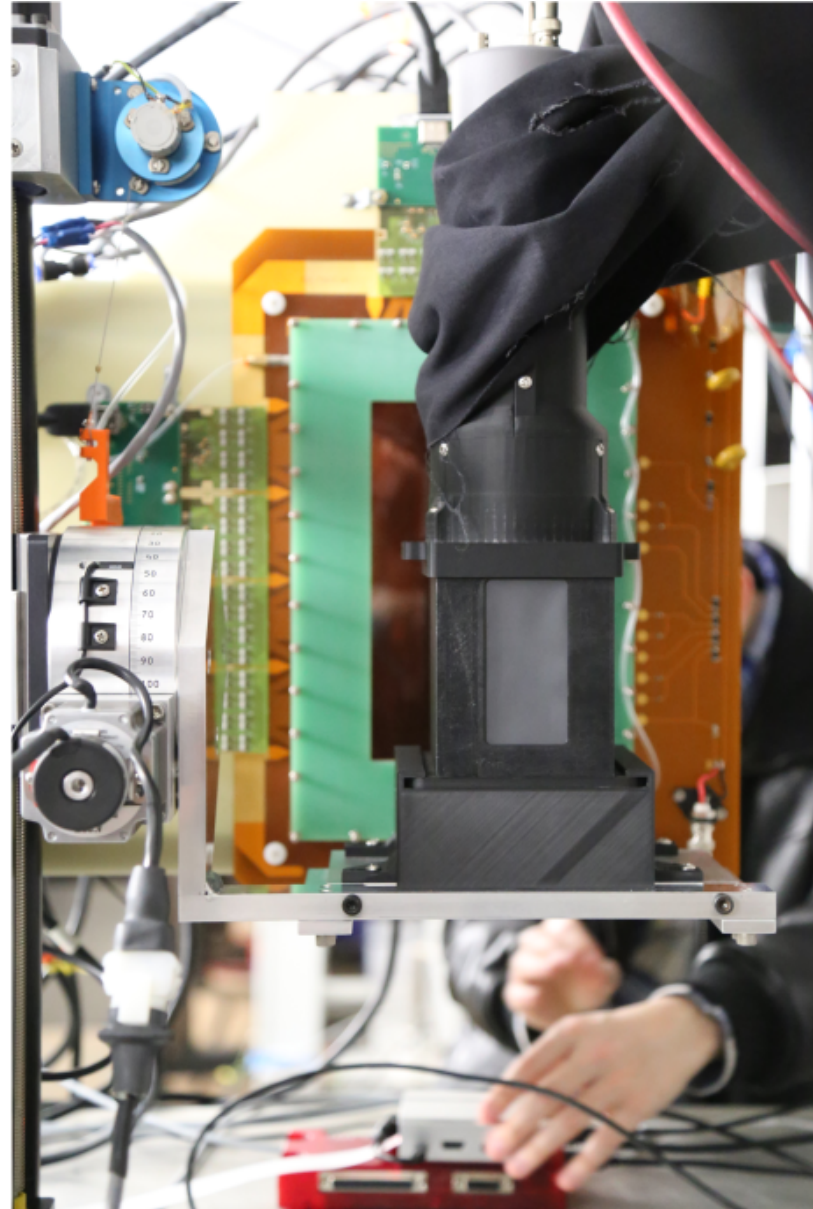

ShowerMax Benchmarking Prototype Testbeam Results (1A and 1B full stack response vs energy)

Benchmarking 1A: Full stack

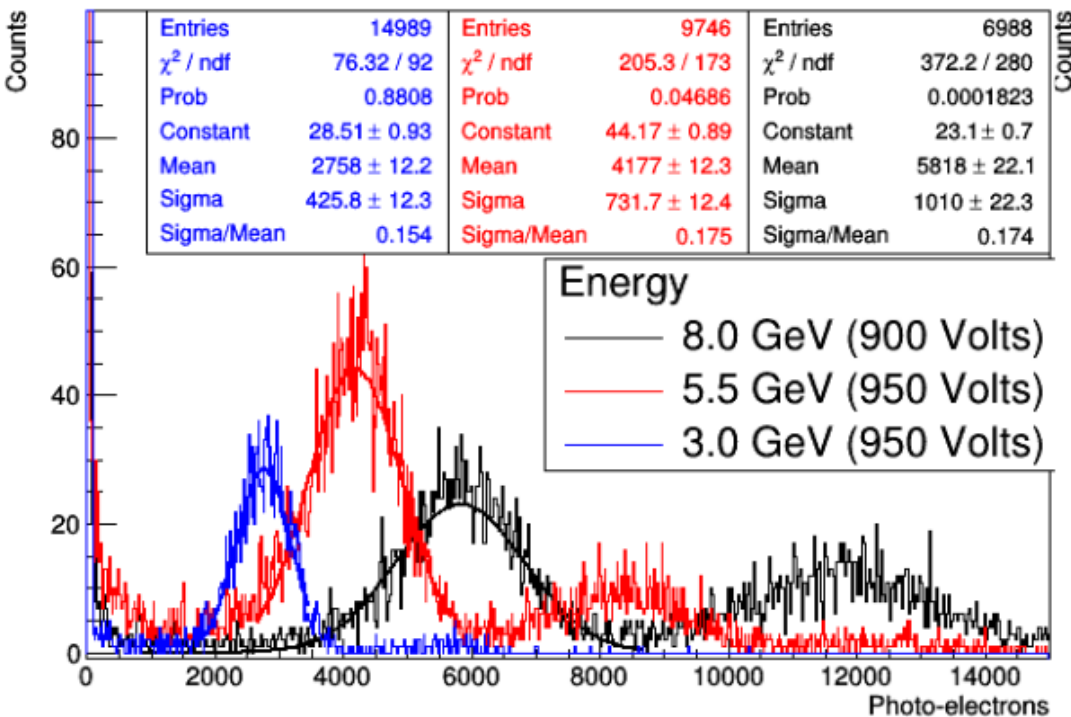

Benchmarking 1B: full stack

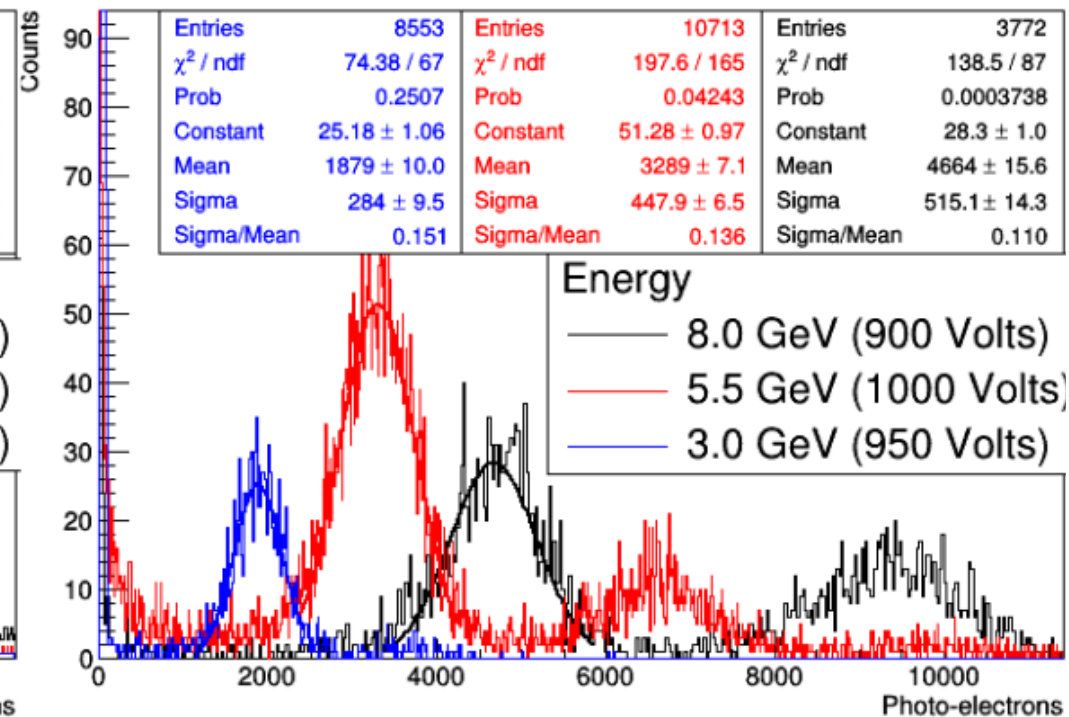

- Comparing these results with previous simulations:
 - For 1A simulation: Mean PEs are ~ 1800 , ~ 4300 , and ~ 6800 for 2, 5, and 8 GeV, respectively
 - For 1A real data: Mean PEs are ~ 2760 , ~ 4200 , and ~ 5800 for 3, 5.5, and 8 GeV, resp.
- Comparisons are promising, new simulations are underway and further refinement of data analysis

Benchmarking 1A testbeam results compared with simulation (5.5 GeV electron response vs. stack layers)

Photo-Electron Distribution - simulated vs real data

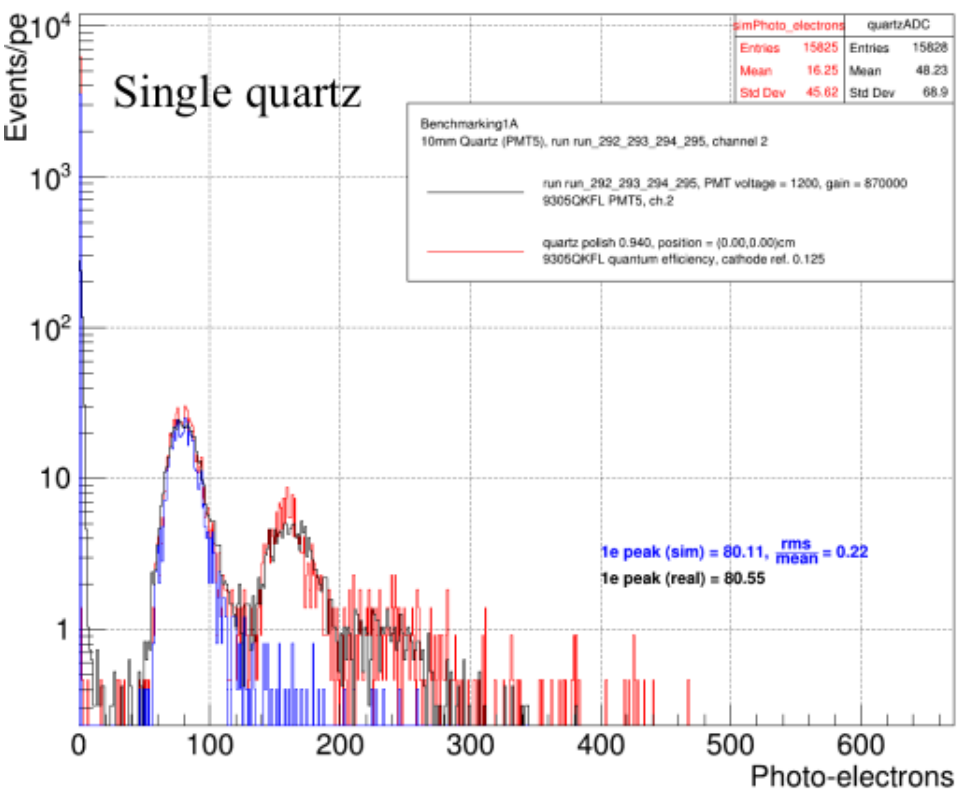
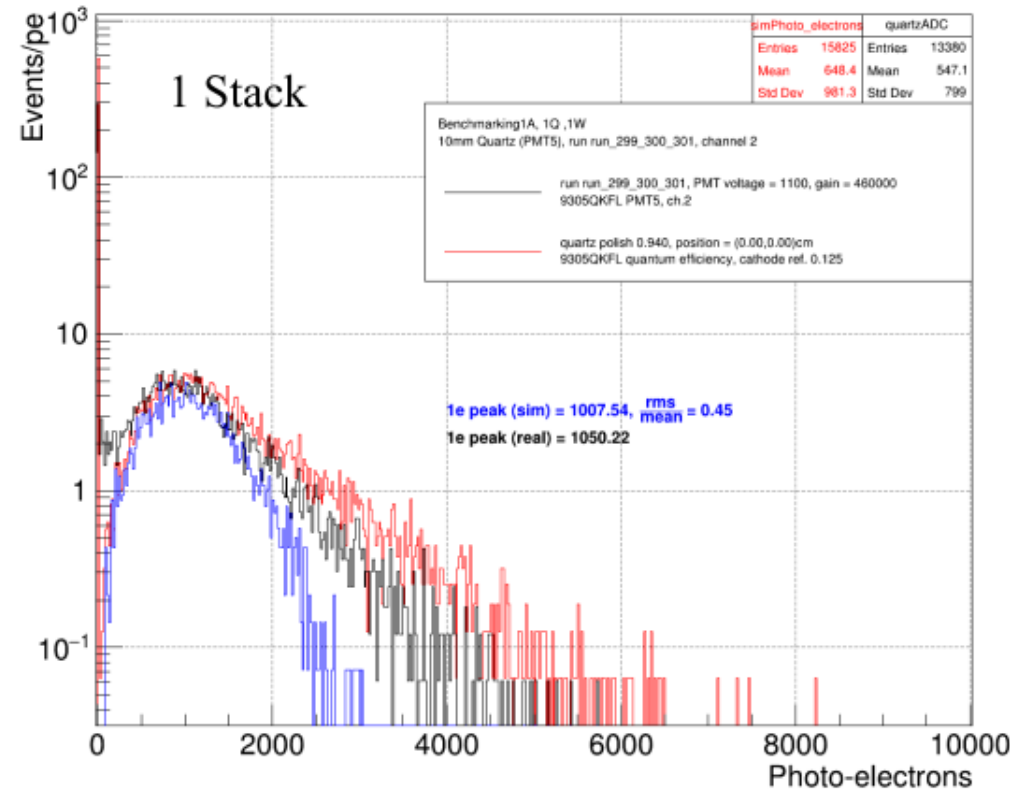

Photo-Electron Distribution - simulated vs real data



- Single quartz data used to benchmark quartz optical polish parameter
- With quartz polish calibrated, simulations performed with successively more stack layers and compared with SLAC data

Benchmarking 1A testbeam results compared with simulation (5.5 GeV electron response vs. stack layers)

Photo-Electron Distribution - simulated vs real data

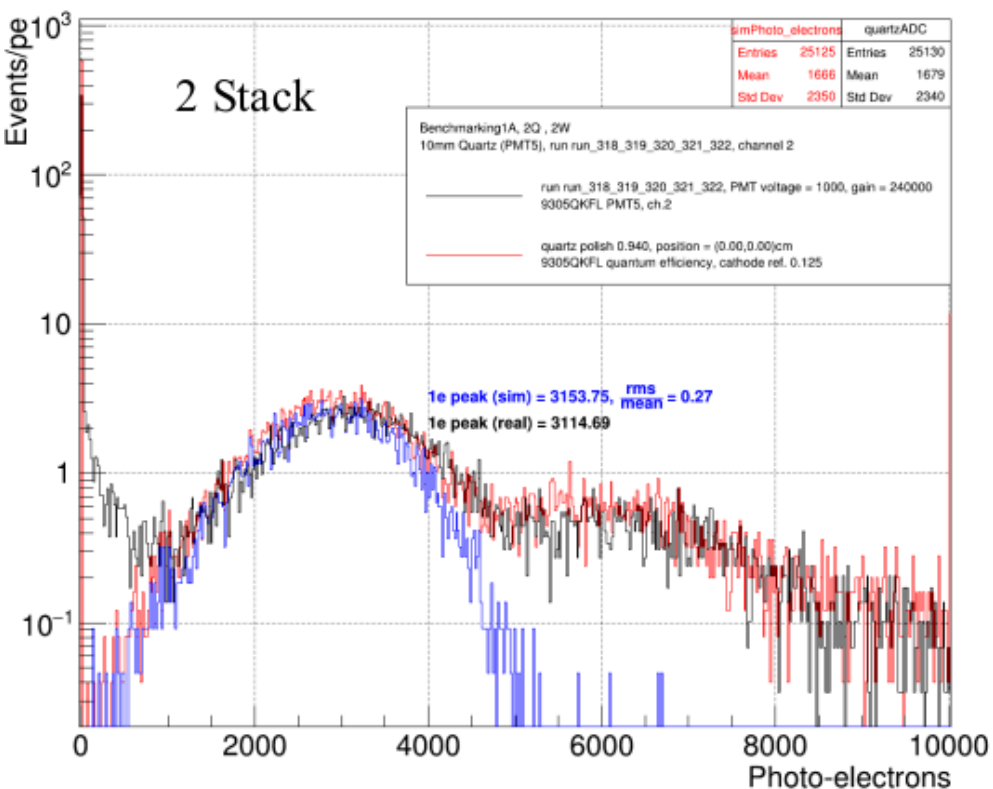
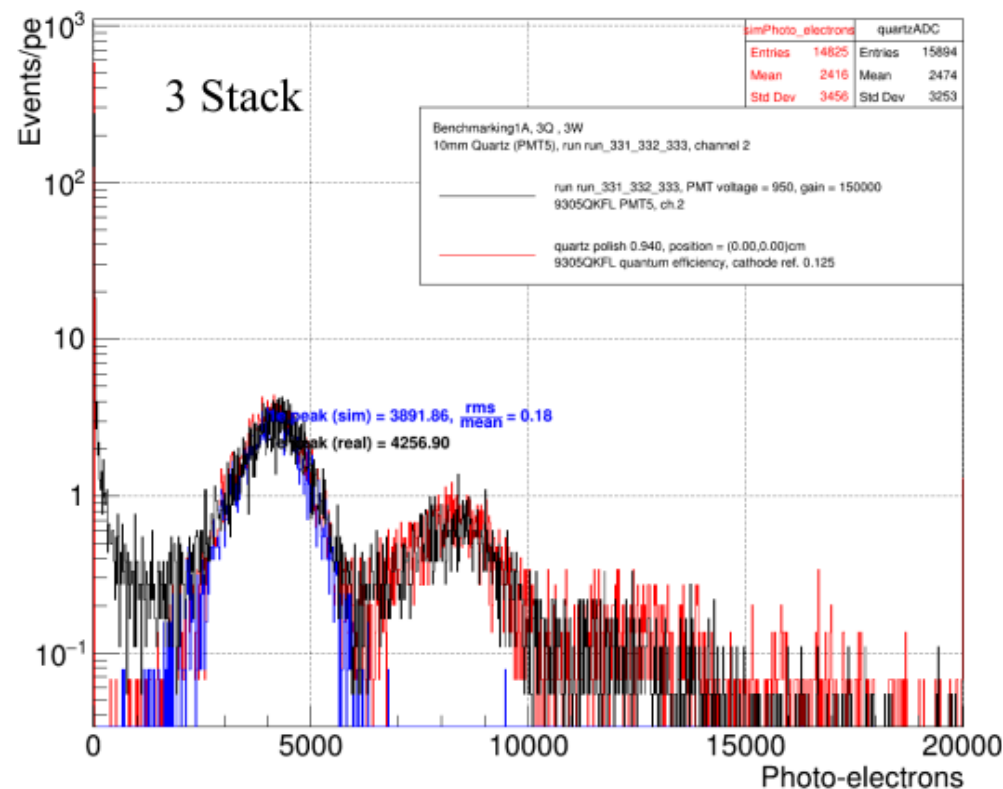

Photo-Electron Distribution - simulated vs real data



- Data and simulation agree well (at 10% level)
- Resolution of single electron photopeak goes from 27% to 18% (simulated)

Full-scale-1A 5.5 GeV Testbeam results

(det1_qdc_hr-1296)*2/0.906/1.602 (Run>=189&&Run<=193&&isGoldenTrack&&isNoisy&&det1_qdc_hr>1320)

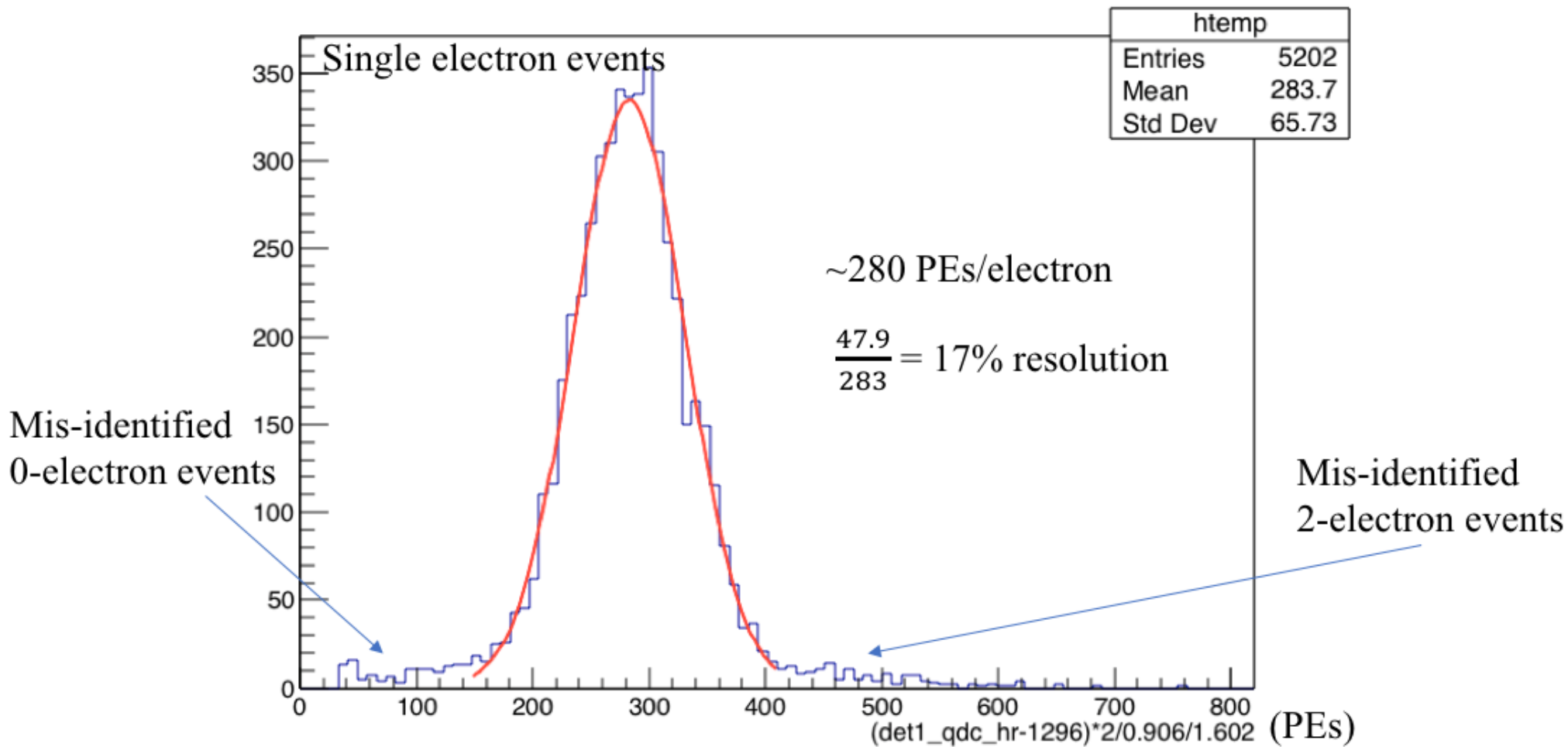

| EXT NO. | PARAMETER NAME | VALUE | ERROR | STEP SIZE | FIRST DERIVATIVE |
|---------|----------------|-------------|-------------|-------------|------------------|
| 1 | Constant | 3.34857e+02 | 6.16283e+00 | 1.65104e-02 | 2.70385e-05 |
| 2 | Mean | 2.83069e+02 | 7.05828e-01 | 2.42615e-03 | -3.14743e-05 |
| 3 | Sigma | 4.79013e+01 | 5.84053e-01 | 1.09882e-05 | 3.24581e-02 |

Summary and future work

- Showermax baseline prototypes constructed and tested
 - Results for benchmarking prototypes in good agreement with simulations
 - Full-scale results show significant difference between data and sims–PE yields $\sim 3x$ lower than expected
- Possible culprit for disagreement is the light guide but could also include unexpected broken TIR–due to excessive pressure on Kapton quartz wrapping during assembly
- Summer plans include using cosmic-rays to further test the full-scale prototypes (why discrepancy with simulations?)
- Updates to the size (active area) of the stack and lightguide length are underway guided by new remol simulations

Backup Slides

Benchmarking 1A Golden Track, single e⁻ data compared with simulation (5.5 GeV electron response vs. stack layers)

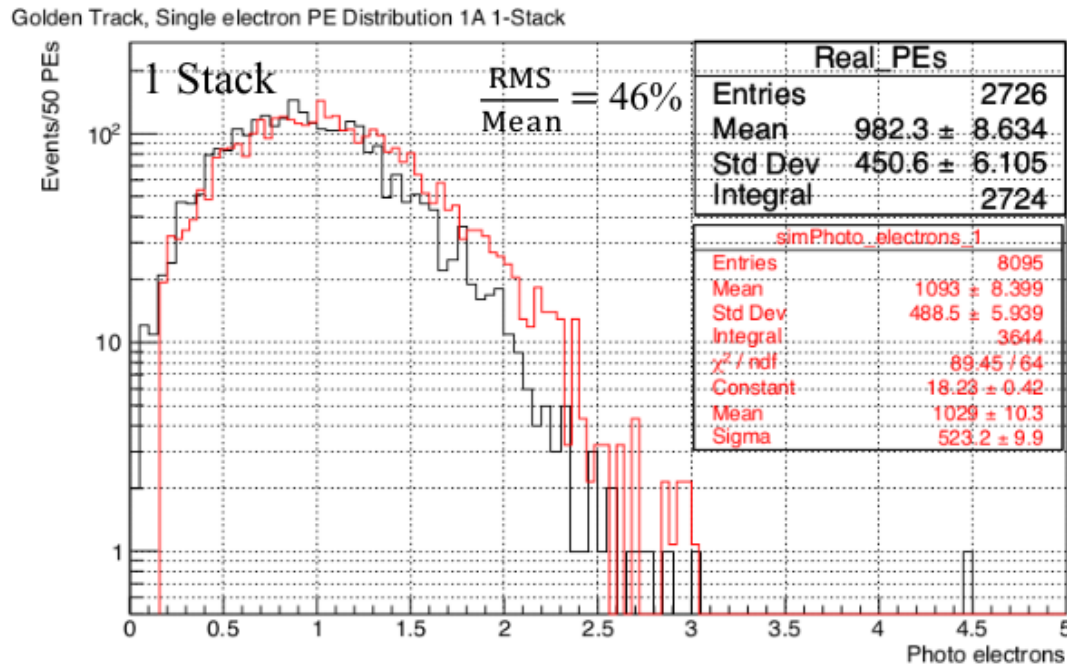
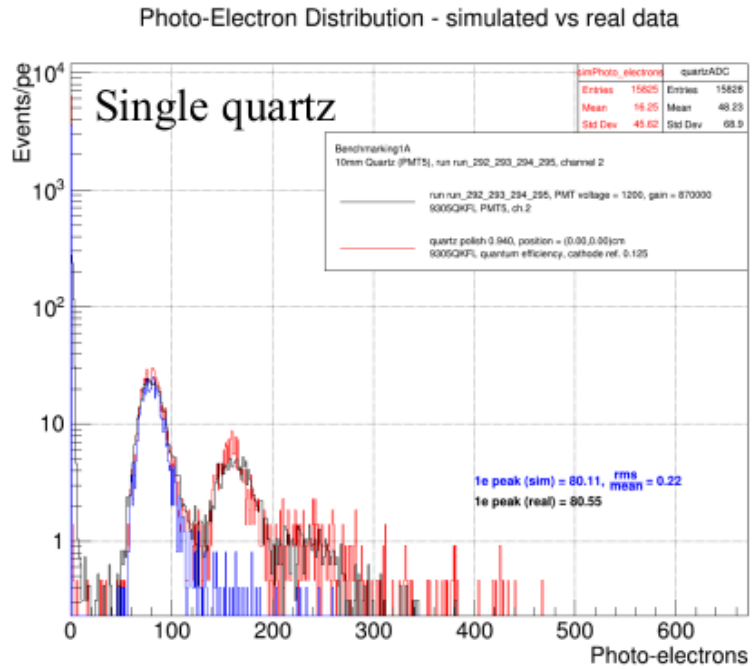

- Note that polish parameter was decreased from 0.98 (PREX) to 0.94 (4% decrease)
- Simulation uses state of the art understanding of optical properties of active material including attenuation and dispersion inside quartz and pmt window, reflectivity at air-pmt window interface & photocathode, and factory QE of photocathode
- Note: All comparisons and polish benchmarking rely on knowing operational pmt gain (5 – 10% uncertainty (as well as QDC charge sensitivity))

Benchmarking 1A Golden Track, single e⁻ data compared with simulation (5.5 GeV electron response vs. stack layers)

Golden Track, Single Electron PE Distribution 1A 2-Stack

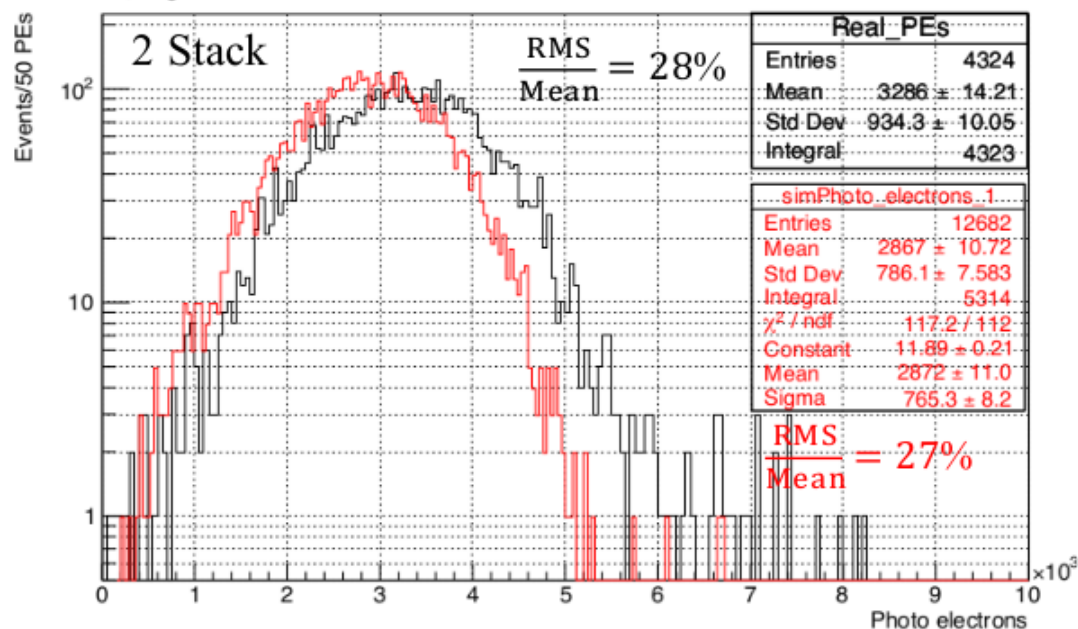

Golden Track, Single Electron PE Distribution 1A 3-Stack

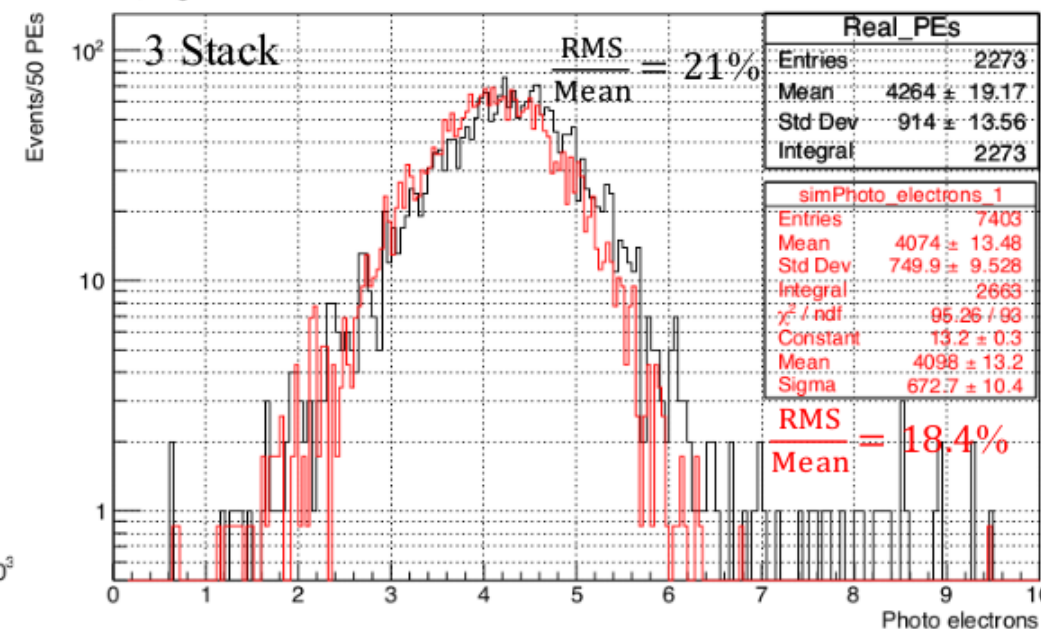

- Data and simulations agree at 10% level
- Data shows larger high-light tails indicating potential mis-identified single e⁻ tracks
- Resolutions get steadily better and agree well with simulated distributions
--This tells us there was good alignment and minimal lateral shower leakage

Linearity Test Box And Integrating DAQ

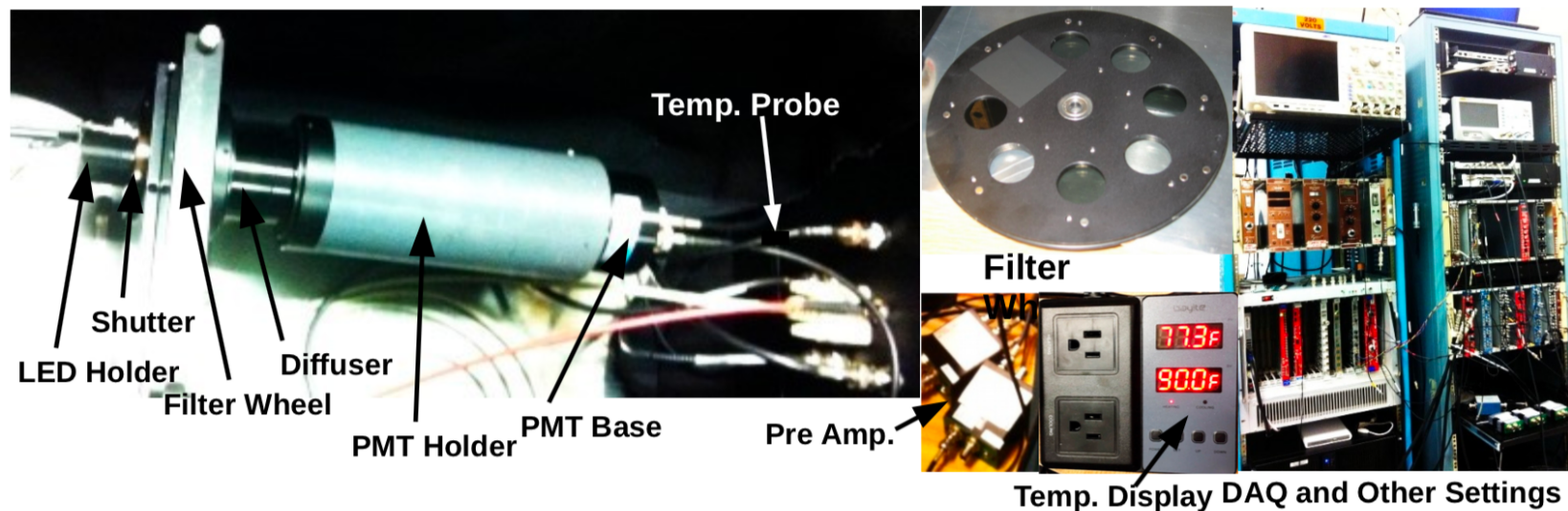

- LED Holder → holds two LEDs, each with 2 mm diameter collimation
- Electronic Shutter → has now been connected with a relay to turn it “ON” and “OFF” automatically at any interval with computer script
- Filter Wheel → Computer Controlled Edmund Optics’ Absorptive ND filters (400-700 nm) with 8 (100, 79, 63, 50, 40, 25, 10, 1)% transmission settings (~randomly ordered)
- Filter Wheel is now controlled automatically using a shell script
- UV Diffuser → Edmund Optics’ ground fused silica
- PMT Holder → 2” PMT with modified base for improved linearity
- Different pre-Amp settings with different resistances and offsets tested (MAIN, LUMI, KDPA, and SNS)

Plans for MOLLER pmt Linearity Measurements

- Apparatus and technique validated for PREX pmts at 240 Hz ff
 - Conclusion: want pmt $I_C \lesssim 15\text{nA}$ and $I_A \sim 20 - 30 \mu\text{A}$
 - Anticipate $< 0.5\%$ non-linearity systematic for PREX-II and even better for CREX
 - Measurements routinely find HV and preamp settings with non-linearity deviations at 0.1 - 0.2% level
- While 30, 120, and 240 Hz ff data give very similar/same results, we see differences at 480 Hz ff—possibly a result of thermal or other instabilities in the flashing LED
- To address expected problems at 960 Hz ff, we plan to implement a chopper wheel setup with phase-locked controller to shutter the LED instead of flash it (M. Gericke's idea)

Plans for MOLLER pmt Linearity Measurements

- ISU group has two ET 9305KQB pmts with factory bases in hand to start testing this fall
 - Anticipated light levels or PE (I_C) currents for central-open ring5 pmts at ~ 16 nA (~ 4 GHz, ~ 25 PEs/ e^-)
 - Will require custom tuned base divider to achieve desired 0.1% non-linearity
 - M. Gericke and group will design bases for future tests; for now, two different factory bases were purchased: one standard circuit and one tapered (for high pulsed linearity)
- A non-trivial complication for precision measurements is calibrating the incident light level or photocathode current. We use special unity gain bases for PREX/CREX; need this for MOLLER

Quartz and Tungsten Ordered in Nov 2017

- For “benchmarking” prototype stack:
 - Quartz: 6 mm (thick) by 86 mm (tall) by 40 mm (wide) --4 pieces (\$975/piece = \$3.9k)
 - Quartz: 10 mm (thick) by 90 mm (tall) by 40 mm (wide) --4 pieces (\$1005/piece = \$4.0k)
 - Tungsten: 6 mm (thick) by 80 mm (tall) by 40 mm (wide) – 4 pieces (\$85/piece = \$340)
 - Tungsten: 8 mm (thick) by 80 mm (tall) by 40 mm (wide) – 4 pieces (\$110/piece = \$440)
 - Tungsten: 2 mm (thick) by 80 mm (tall) by 40 mm (wide) – 4 pieces (\$25/piece = \$100)
- For “full-scale” prototype stack:
 - Quartz: 6 mm (thick) by 111 mm (tall) by 246 mm (wide) -- 4 pieces (~\$1750/piece = \$7.0k)
 - Quartz: 10 mm (thick) by 115 mm (tall) by 246 mm (wide) -- 4 pieces (~\$1940/piece = \$7.8k)
 - Tungsten: 6 mm (thick) by 105 mm (tall) by 246 mm (wide) – 4 pieces (\$600/piece = \$2.5k)
 - Tungsten: 8 mm (thick) by 105 mm (tall) by 246 mm (wide) – 4 pieces (\$820/piece = \$3.2k)
 - Tungsten: 2 mm (thick) by 105 mm (tall) by 246 mm (wide) – 4 pieces (\$200/piece = \$0.8k)

Purchasing these pieces allows for Configs 1, 3, and 4 (A and B) to be tested

Total quartz: \$25k, total tungsten: \$7.5k: Total = \$32.5k

- This purchase enables construction of two benchmarking and two full-scale prototype sets
- Building two sets of prototypes will allow for more efficient testing during both SLAC testbeam and cosmic tests at SBU and ISU. We can each build a different configuration to test

Prototype Designs for Testbeam

Shower-max Benchmarking Prototype concept

- Concept allows stack to be assembled and beam-tested one piece at a time for detailed benchmarking study
- Fabricated with ABS plastic using 3D printer

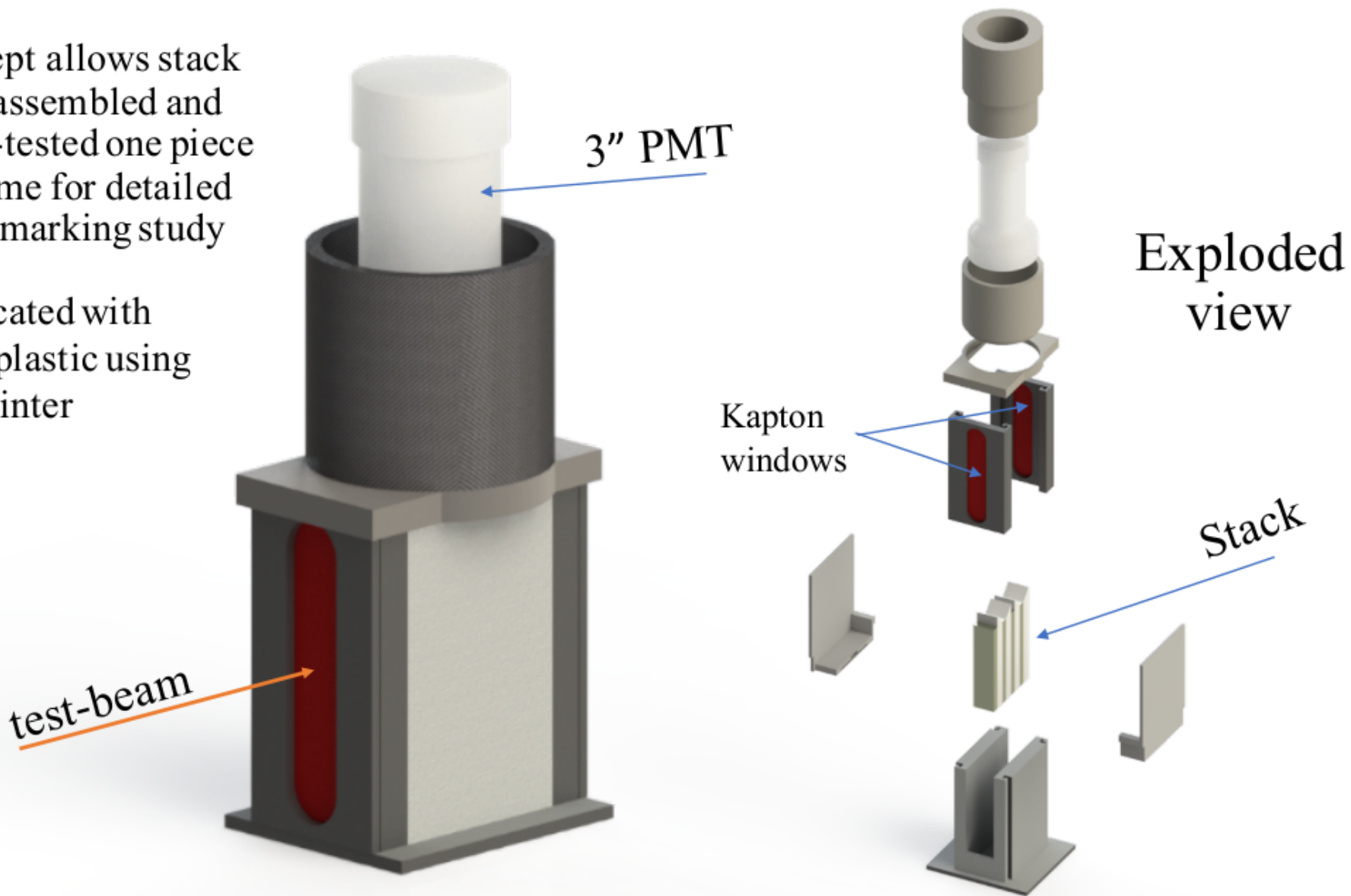

Config #1 (original baseline) benchmarking Prototype

Benchmarking Stack Configurations

Highlighted columns show changes due to quartz thickness change: **Examined 6 mm and 10 mm thick tiles**

| Config # | t_f (mm) | t_q (mm) | t_w (mm) | b (mm) | a (mm) | X_0 | R_{molier} (mm) |
|----------|------------|------------|------------|--------|--------|-------|--------------------------|
| 1A | 8 | 10 | 8 | 64 | 44 | 9.5 | 11.0 |
| 2A | 17 | 10 | 5 | 55 | 55 | 9.5 | 11.0 |
| 3A | 14 | 10 | 6 | 58 | 52 | 9.5 | 11.0 |
| 4A | 6 | 10 | 6 | 58 | 52 | 7.3 | 11.5 |

| Config # | t_f (mm) | t_q (mm) | t_w (mm) | b (mm) | a (mm) | X_0 | R_{molier} (mm) |
|----------|------------|------------|------------|--------|--------|-------|--------------------------|
| 1B | 8 | 6 | 8 | 48 | 61 | 9.5 | 11.0 |
| 2B | 17 | 6 | 5 | 39 | 67 | 9.5 | 11.0 |
| 3B | 14 | 6 | 6 | 42 | 65 | 9.5 | 11.0 |
| 4B | 6 | 6 | 6 | 42 | 65 | 7.3 | 11.5 |

- ❖ Key benefit here is that the parameter “a” (the width of the benchmarking quartz tiles) can now be comfortably large to ensure negligible transverse shower leakage.

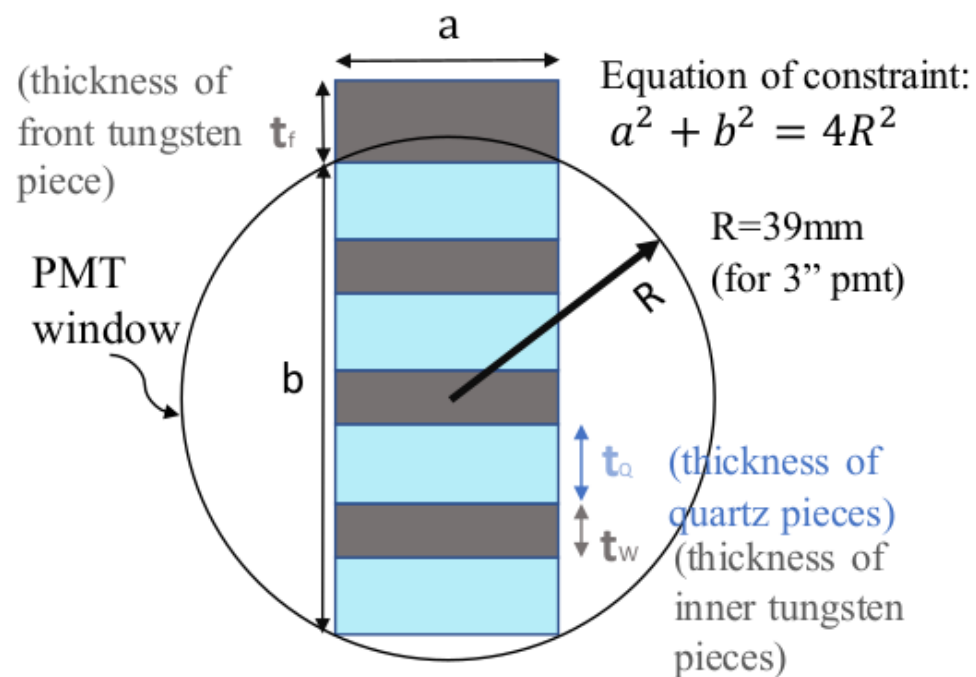

1A - 4A Mean PE and Resolution versus Energy

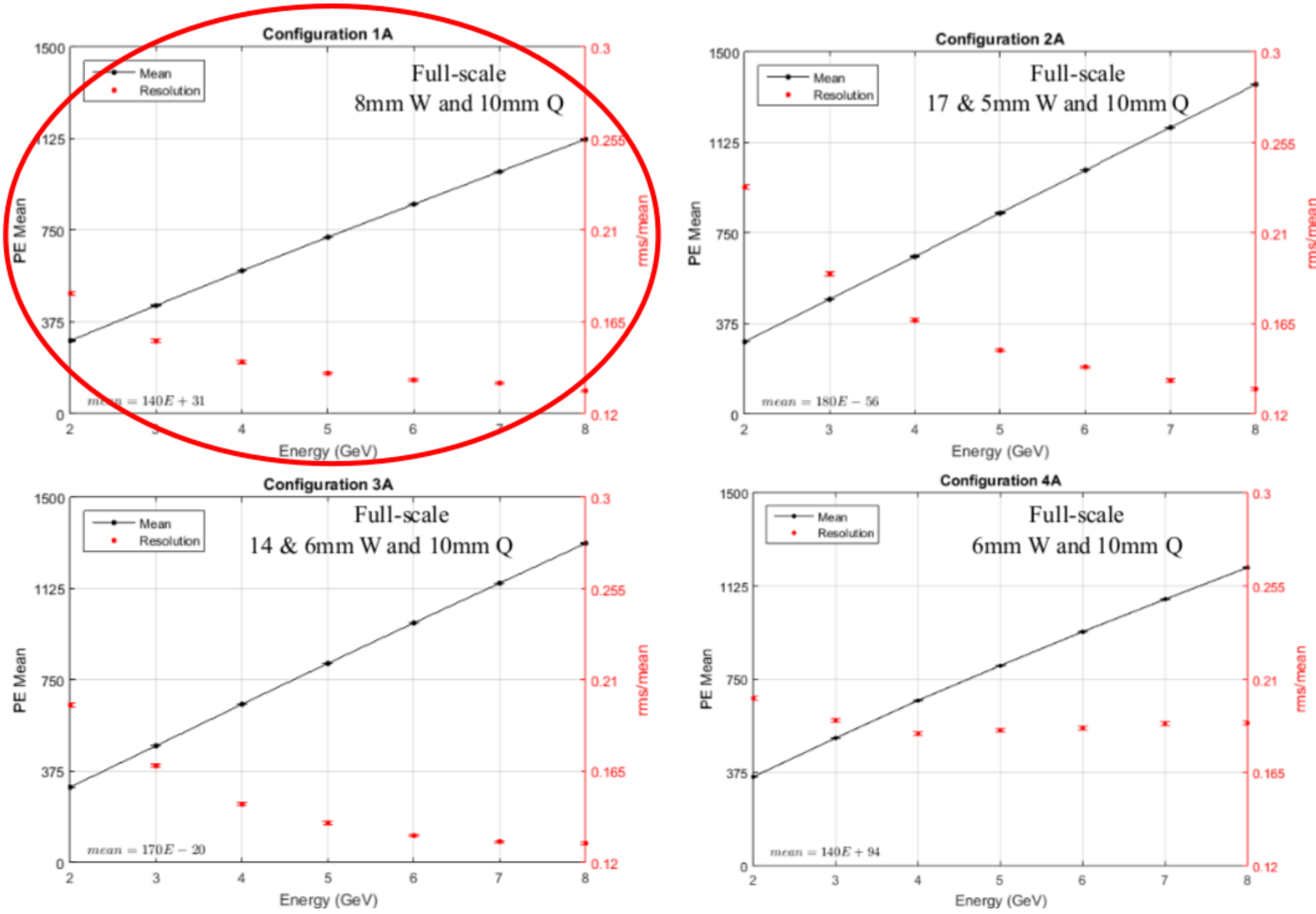

Simulation results for B configs (6mm quartz)

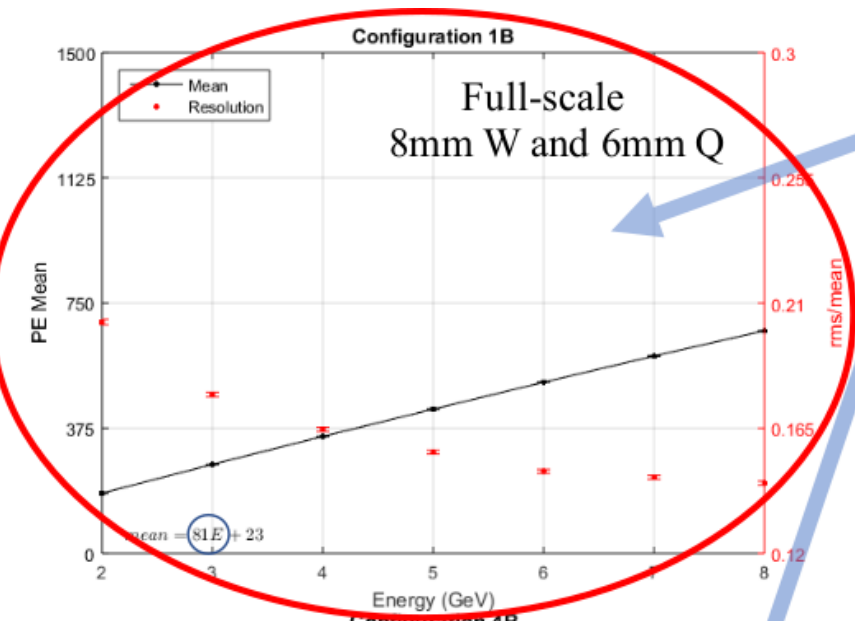

- The B configs have ~half the slope of the other configs – 80 PE/GeV – while maintaining good resolution and with lower light levels.
- The reduced slope means less variation in PE yields with energy--which will reduce the widths measured during helicity window (it seems a potential win win win situation)
- Also interesting is that if you reduce the layers of tungsten to 4mm, the resolution worsens ~drastically (even with 10 mm quartz)

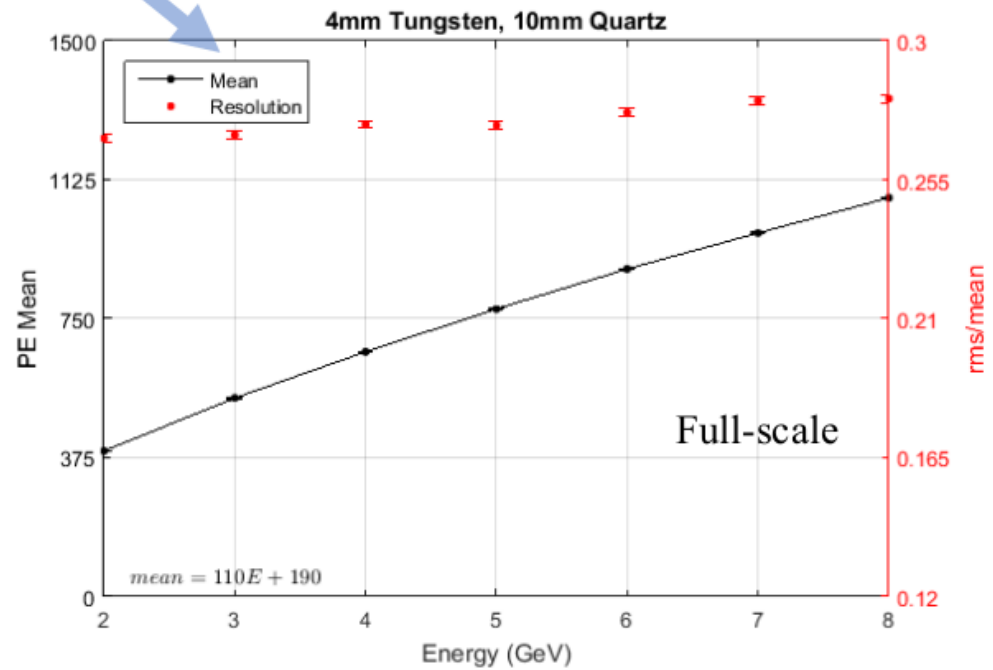
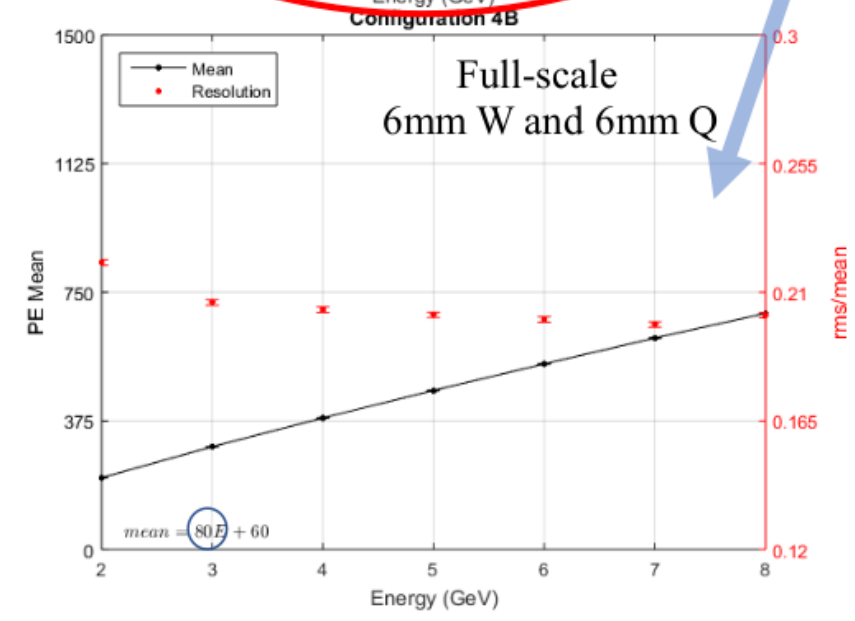

Prototype Construction and SLAC Testbeam Run

1A Full-scale Stack Assembly at SBU, June 2018

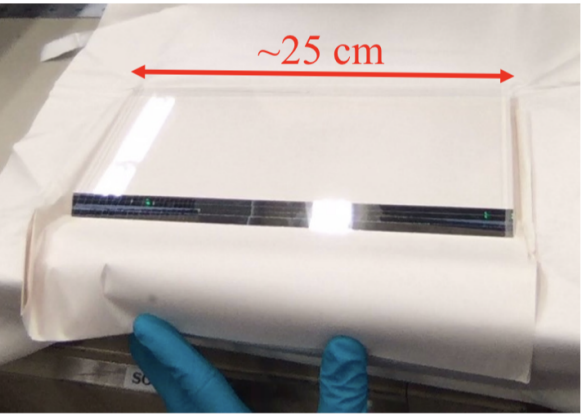

~25 cm

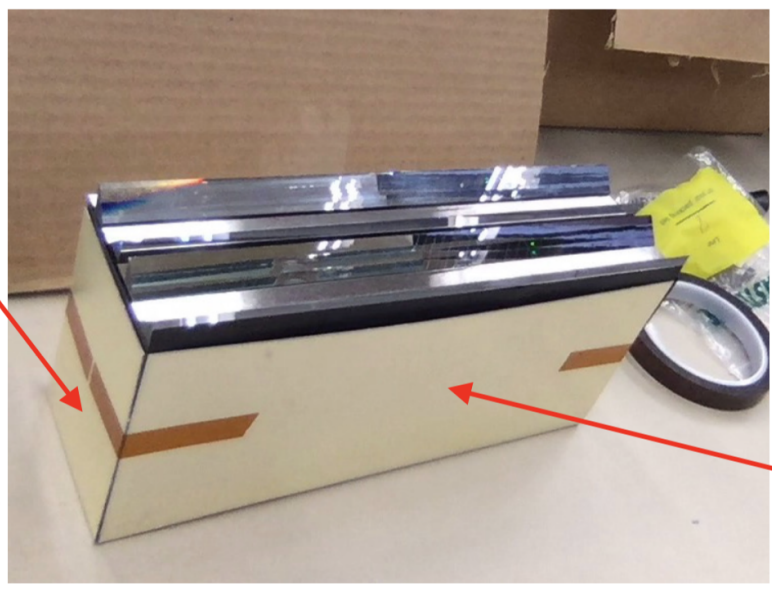

Aluminum sheet coffin

Fully assembled stack weighs ~40 lbs



8 mm thick 99.95% pure tungsten plates

Quartz wrapped in black Kapton

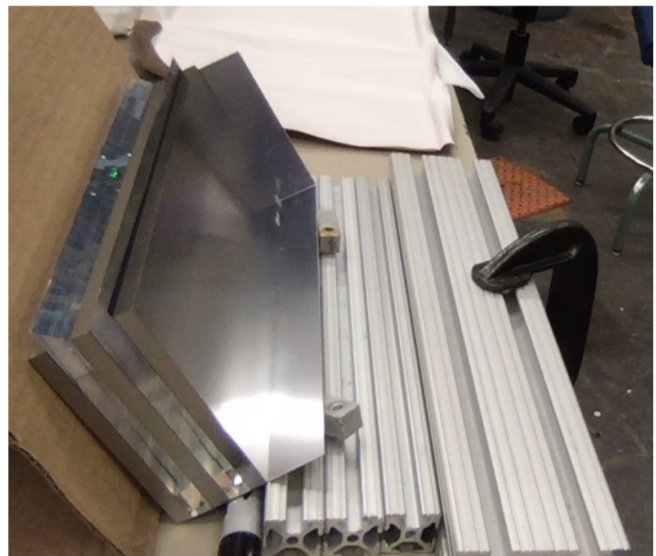

July 16, 2018

MOLLER Task Tracking Bluejeans Meeting

15

Assembled 1A Full-scale ShowerMax Prototype

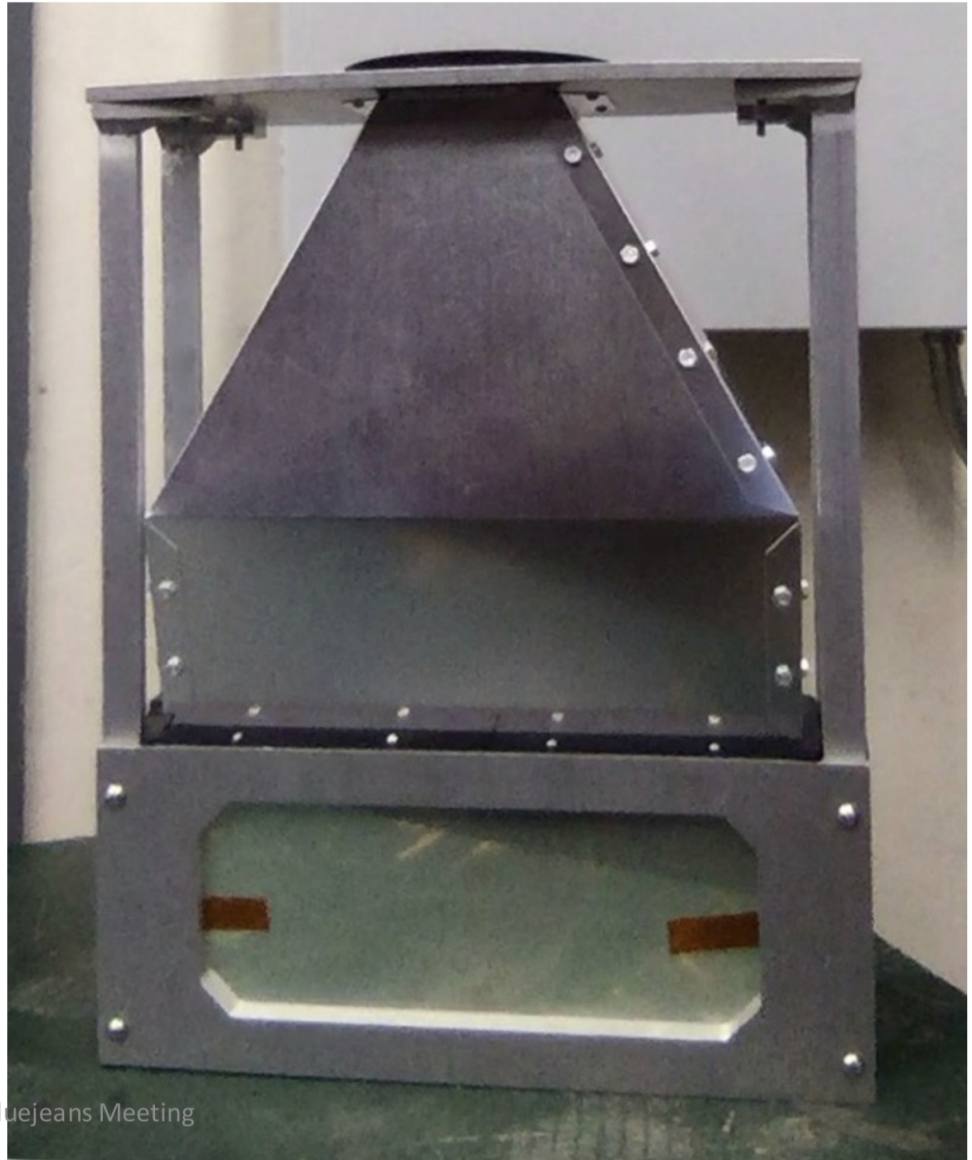
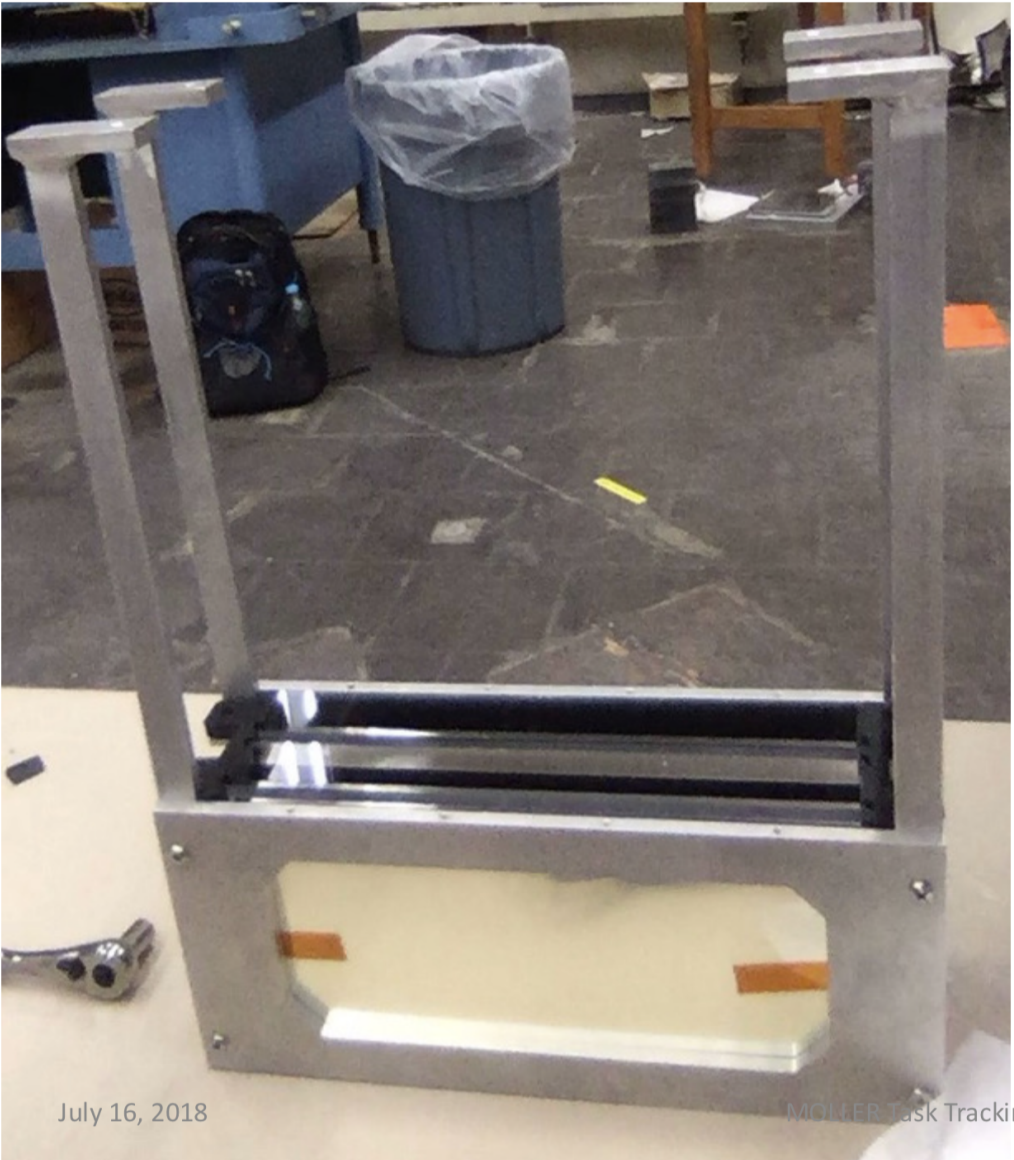

Testbeam and MC benchmarking strategy

- Engineer benchmarking prototype capable of operation with systematically more stack layers added and with no light guide
- Basic strategy outline:
 - First take data with only one piece of quartz
 - Then add the front tungsten plate and take data, then the next layer of tungsten and quartz, then next, then next
 - This will facilitate benchmarking of optical quartz properties and G4's showering process without light guide complication
- Also construct and test full scale prototypes (with same exact stack configuration as benchmarking prototype) and with full light guide; this will be constructed with machined aluminum

Benchmarking Prototype (1A) Expectations

Benchmark 1A: Single Quartz

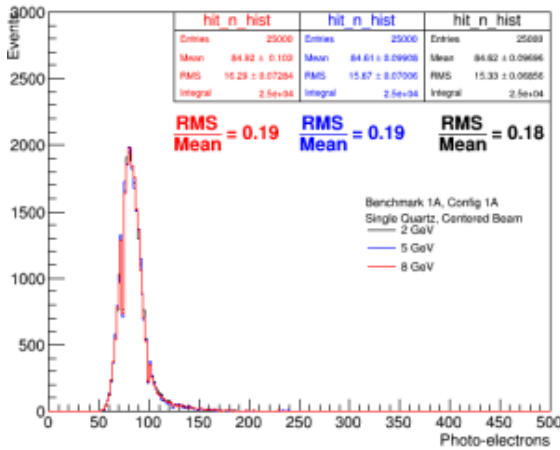

Benchmark 1A: n=1

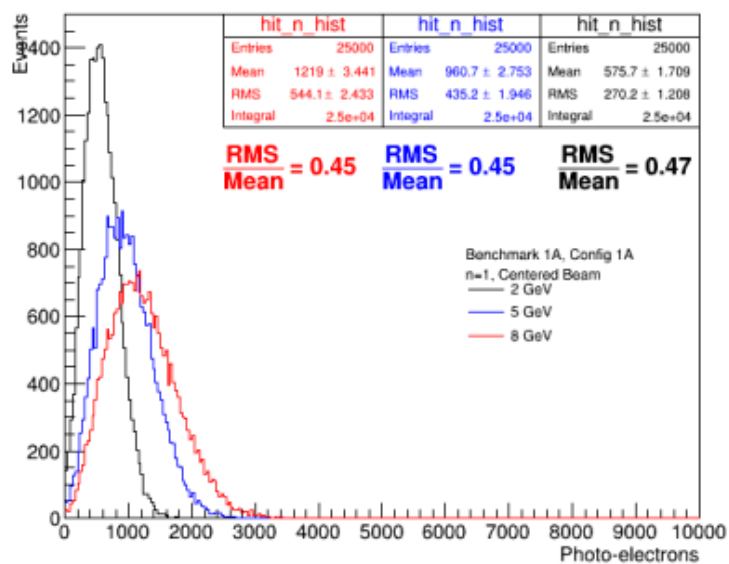

Benchmark 1A: n=2

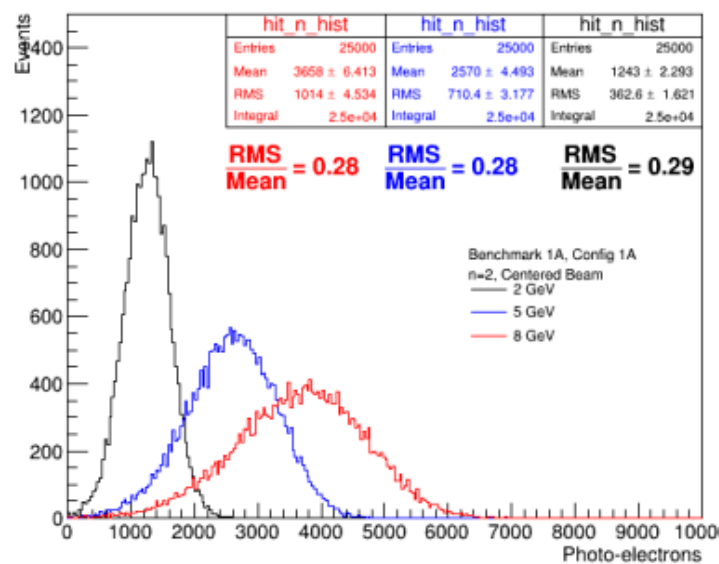

• Benchmarking PE yields are incredibly high for n=1 to 4

Benchmark 1A: n=3

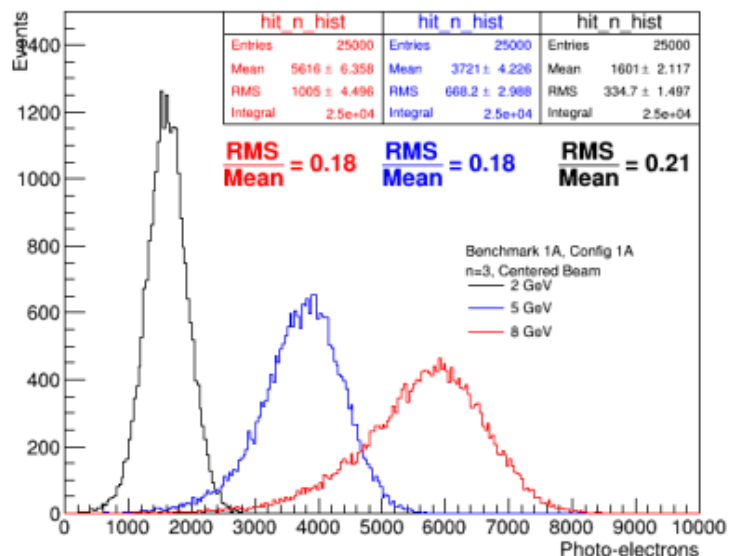

Benchmark 1A: n=4

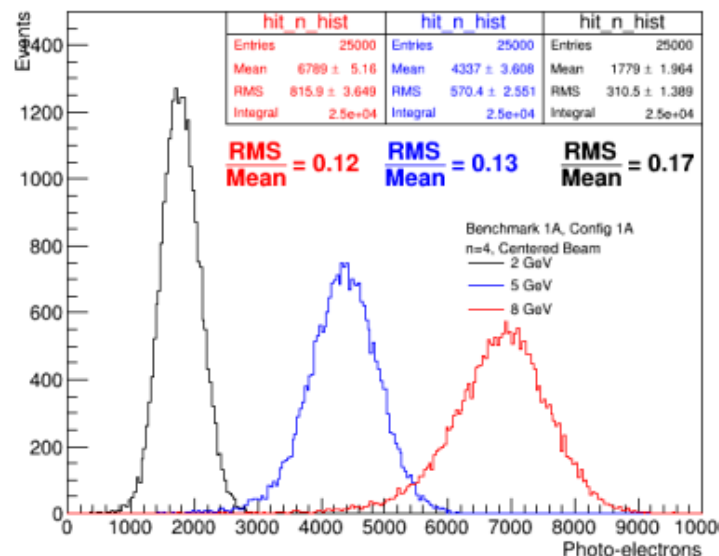

• Will use 3" ET PMTs: 9305QKB

CAD of the SLAC testbeam setup

- Testbeam scheduled for Dec 5 – 10 (we may get more time)
- Setup allows testbeam to cover entire active area of full-scale prototypes

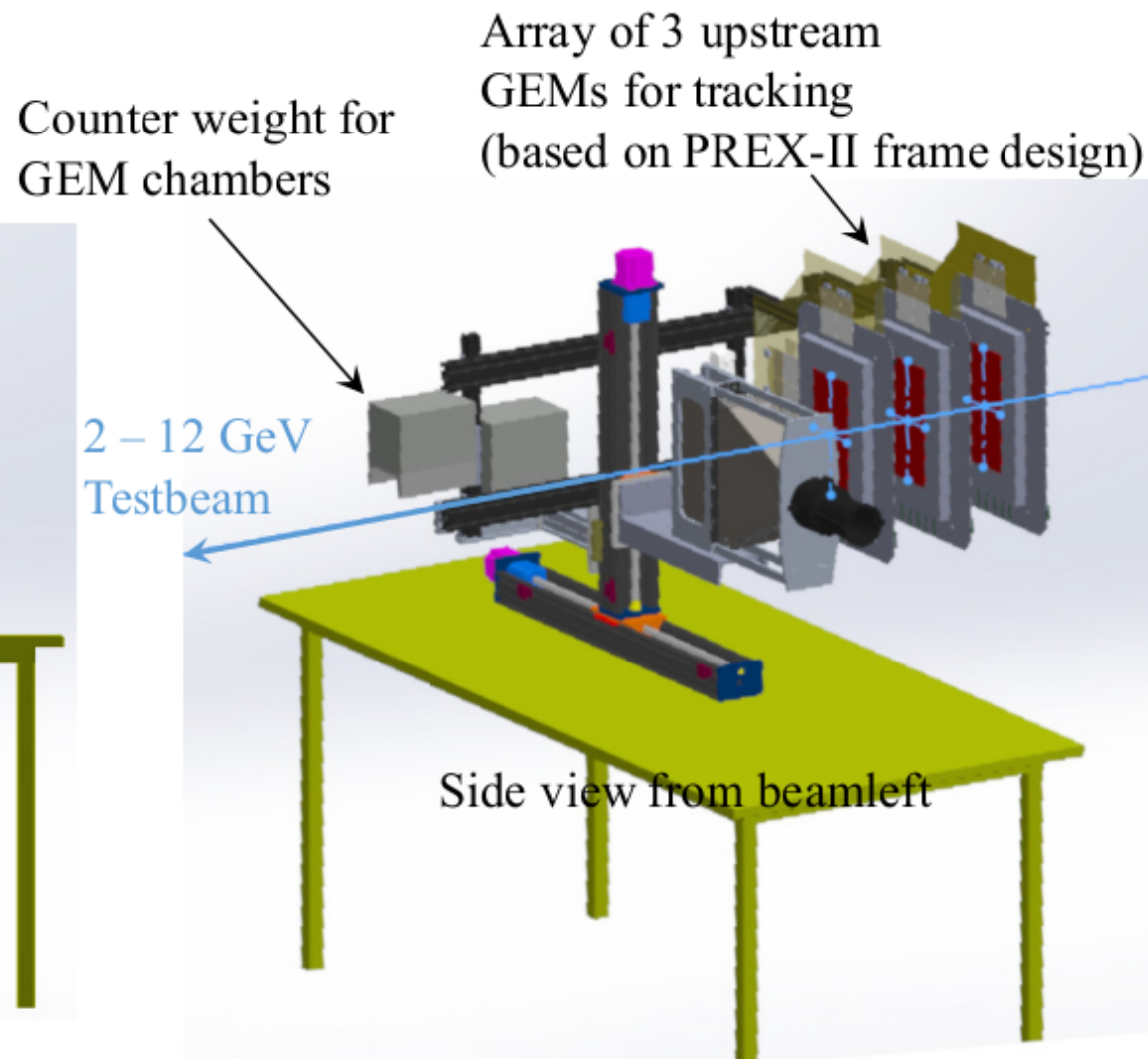
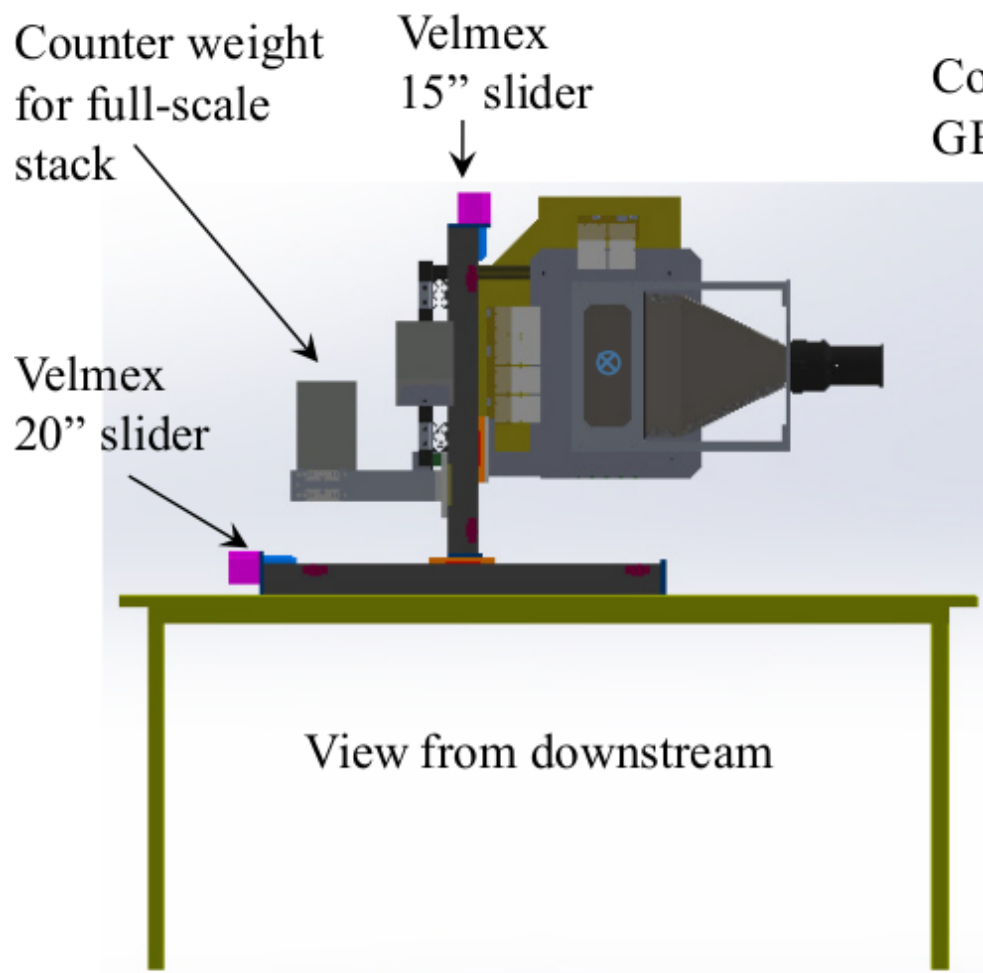

Beam Spot (5.5 GeV): ~1 cm by 2 cm

Det 2 XY hits

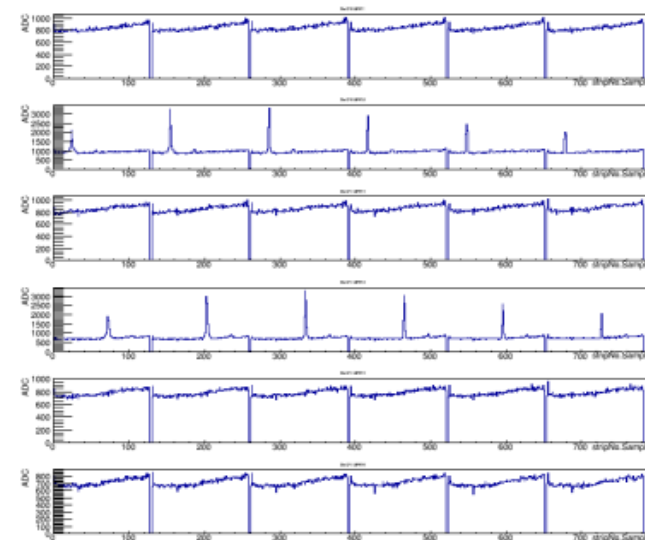
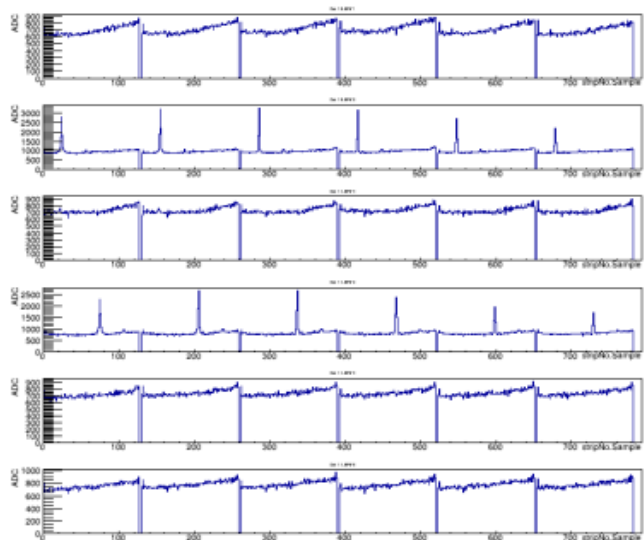
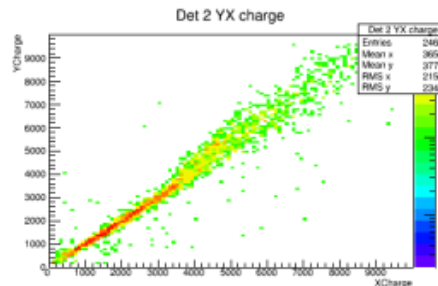
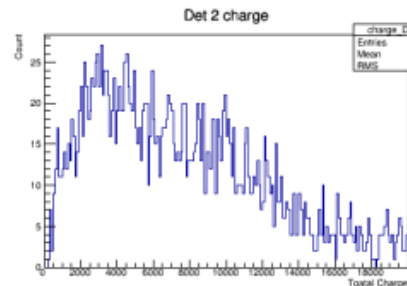
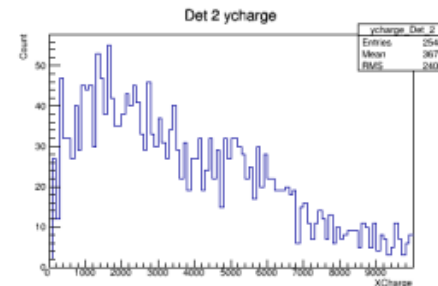
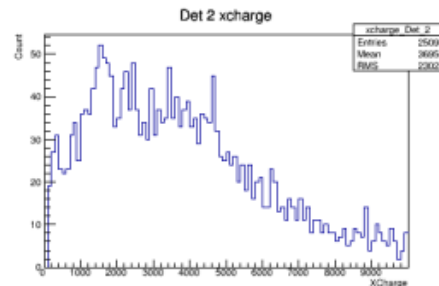
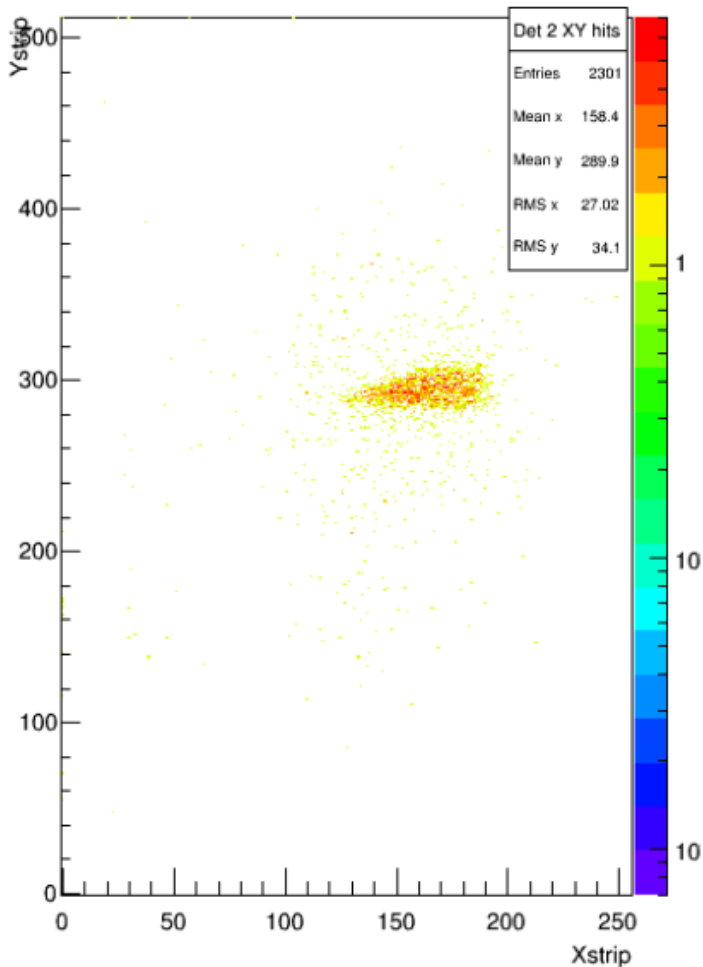

SLAC Testbeam sample data (from PREX Tandem Det) Run 417

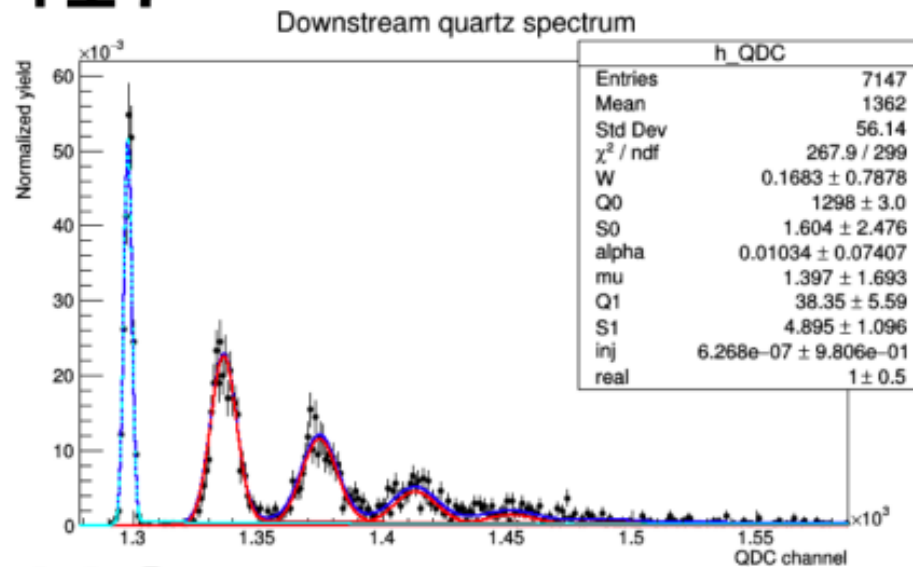
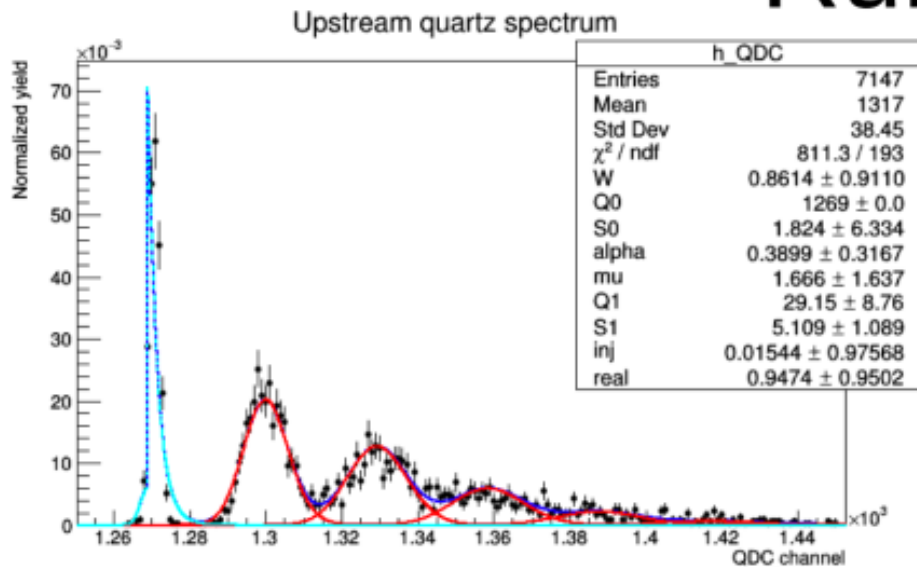

Run 418

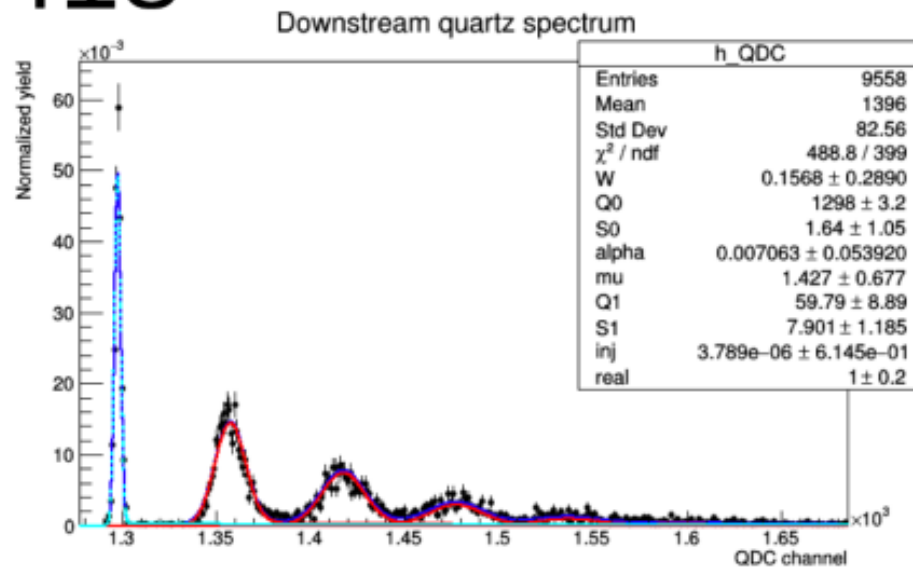
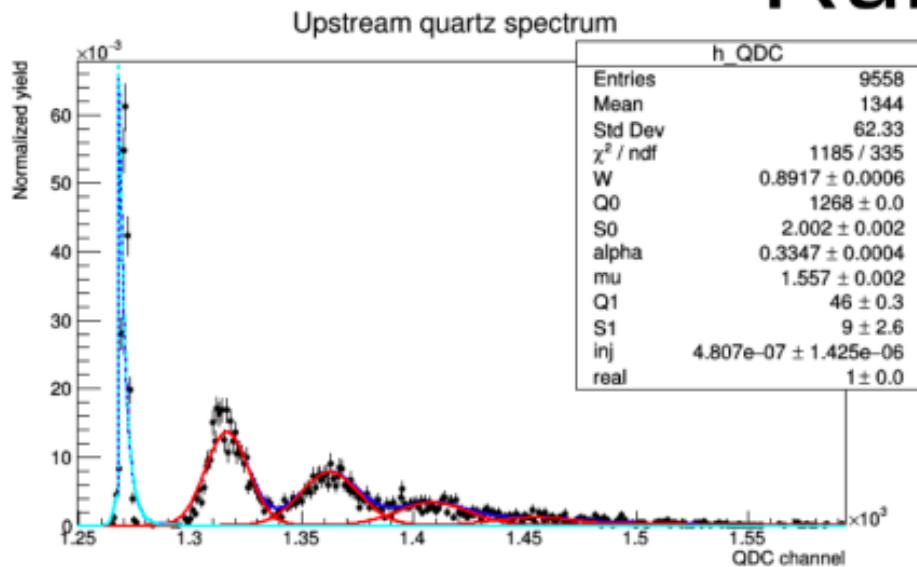

ShowerMax Benchmarking Prototype Testbeam Results (1B response vs. stack layers)

Benchmarking 1B: Compare stacks

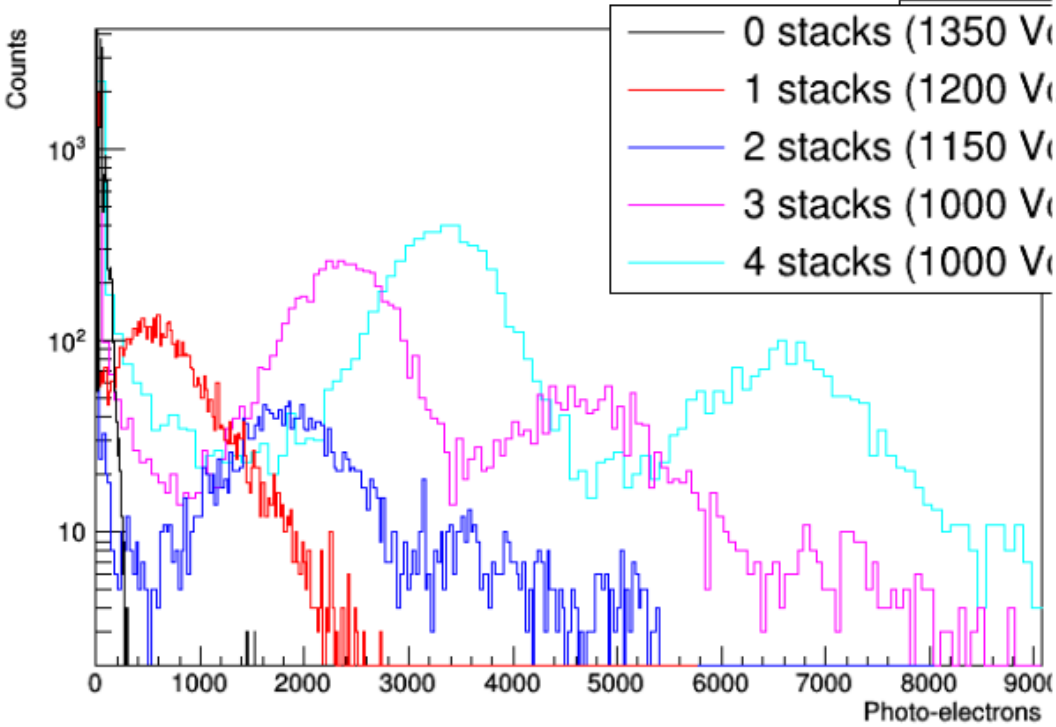

Benchmarking 1B: Compare stacks

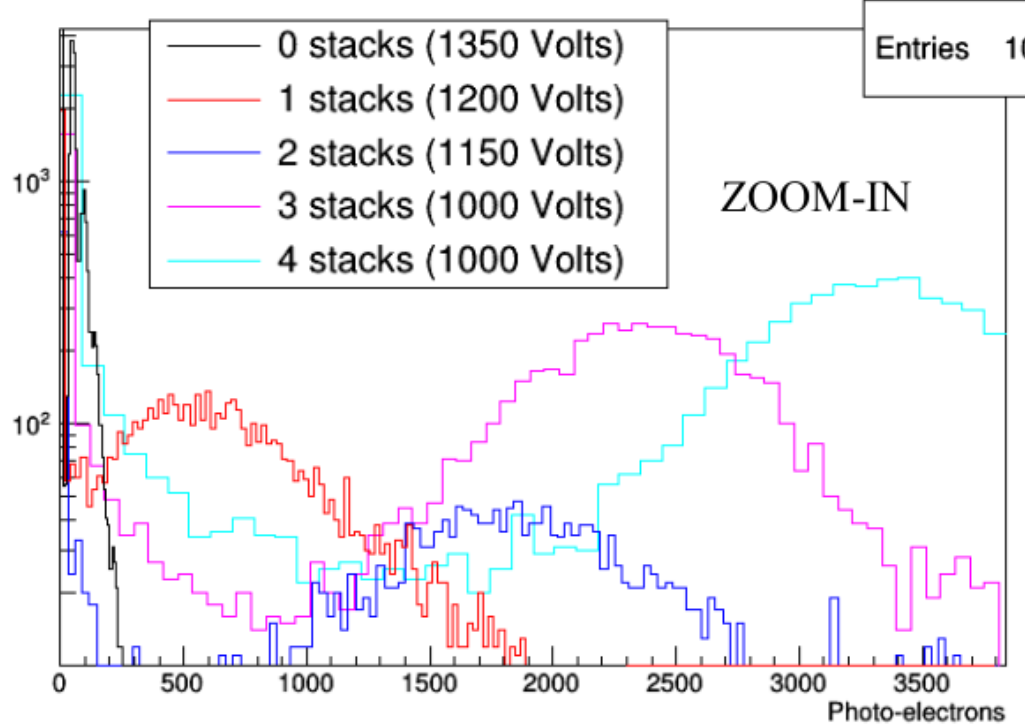

- Results are very reasonable—the means and relative widths behave as expected
- Simulations are underway for comparison and MC tuning/benchmarking

Benchmarking 1A testbeam results compared with simulation (5.5 GeV electron response vs. stack layers)

Photo-Electron Distribution - simulated vs real data

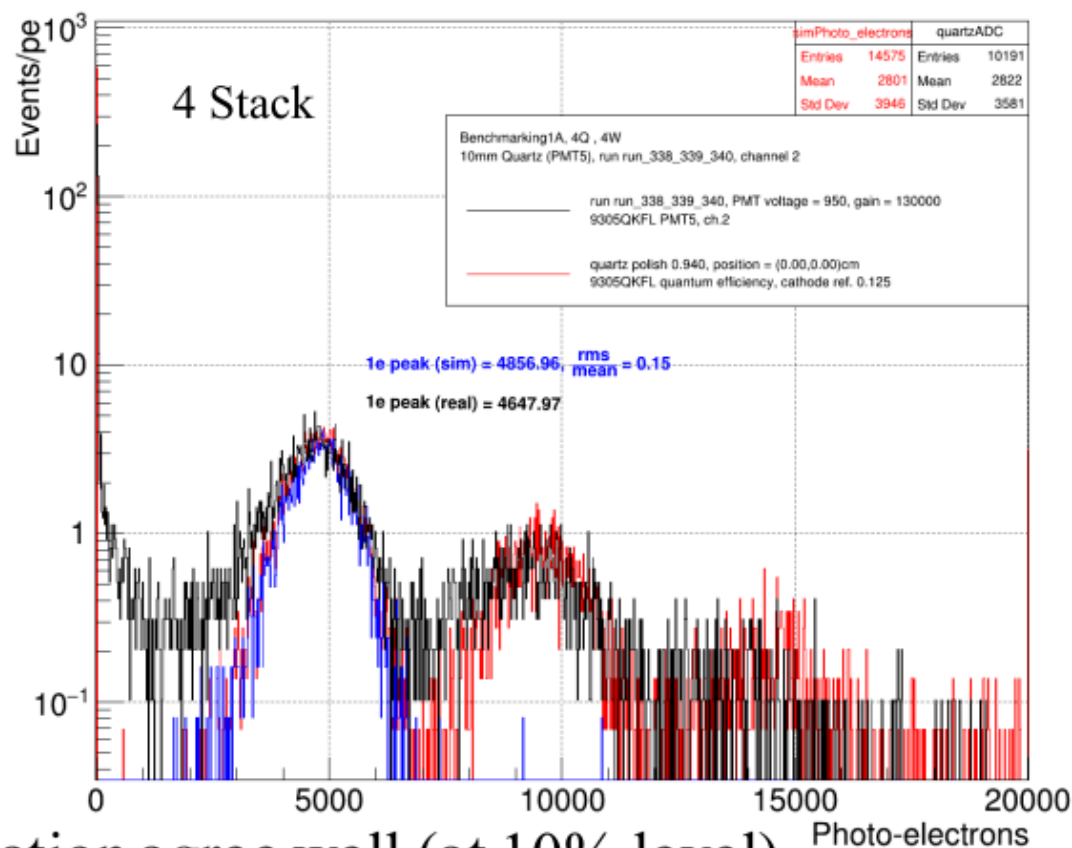

- Data and simulation agree well (at 10% level)
- Resolution of single electron photopeak is 15% (simulated). Analysis of real data resolutions are on-going using GEM tracking data

MOLLER Task Tracking: ISU Tasks

| Subsystem | Task | Description | Status | Owner | Relation to Director's Review Report | Estimated Completion Date |
|------------------|--|---|--|--------|--|---------------------------|
| Detectors | Radiation hardness of detector components | Investigate which detector components need radiation testing and carry out 50 MRad test | Michael and Dustin devise a plan. Status: Initial list being established | Dustin | Page 12: ``..., all components in the scattered beam envelope should show negligible damage up to 50 MRad.'' | May 2019 |
| Detectors | QC plan for main detector quartz | Devise plan to evaluate robustness of main detector quartz (Redundant with ``radiation hardness of detector components'') | Michael and Dustin to devise a plan? Not yet started | Dustin | Page 12: Recommendation: ``Conduct radiation damage tests to at least 50 MRad to qualify fused silica for use in the thin detector | May 2019 |
| Detectors | Shower-Max module mechanical assembly design | This task incorporates the physical design and prototyping of the showerMax detector, as well as the associated mechanical mounting structure | Advanced state of first prototype design, including mechanical assembly | Dustin | Not explicitly mentioned | May 2018 |

Radiation Hardness Test plan Update

- Radiation hardness testing of mechanical assembly materials and parts (ISU, UM)
 - ❖ Irradiated several light-guide (LG) material samples over a 3 day test run from Mar 22 - 24, 2016 at the Idaho Accelerator Center (IAC) using 8 MeV, 65 mA I_{peak} , 4 μ s pulse width at 250 Hz rep-rate (dose exposure rate was calculated but too high to measure):
 - Measured LG specular reflectivity for 200 – 800 nm at 90, 60, 45, and 30 degrees.
 - No measurable change in reflectivity was detected for $\gg 50$ MRad exposure
 - ❖ Other assembly materials to test could include Kapton and Tedlar (light tight wrappings) and possibly 3D-printed custom plastic assembly components (Nylon, ABS, PLA, ...) as well as high-density shielding plastics, epoxies, ...
- Radiation hardness testing of electronic components: active bases, preamps, ... (ISU, UM)
- Main Detector Quartz Robustness (radiation hardness, QA, etc.) (ISU, UM)
 - ❖ Apparatus developed to make relative transparency measurements between 200 – 800 nm
 - Uses Ocean Optics USB spectrometer, UV-Visible light source, custom holder/stand
 - ❖ Energy deposition calculations (dE/dx and brem) underway for 8 MeV beam and 1.5 cm thick quartz—for heating and thermal expansion considerations (do not want to crack quartz)
 - ❖ Developed plan to calibrate and monitor beam dose exposure during study
 - ❖ Had a 1 day IAC test run on May 31, 2018; dose exposure rates calibrated; performed preliminary quartz irradiation test

Radiation Hardness QA for quartz and other components

25 MeV LINAC (Main Hall and Airport)

RF Frequency: 2856 MHz (S-Band)
 Energy Range: ~4~25 MeV (current varies)
 Pulse Width: ~50ns to 4 micro seconds
 Repetition Rate: single pulse to 360 Hz
 Ports: 0 degree, 45 degree and 90 degree (Beam energy resolution ~ 1+/- 15%)

| 25B Energy vs Current | | | |
|-----------------------|-------------|--------------|--------------|
| Energy (MeV) | 0 port (mA) | 45 port (mA) | 90 port (mA) |
| 23 | 55 | 55 @ 3.8uS | 46 @ 3.6uS |
| 20 | 100 | 70 @ 4 uS | 65 @ 4 uS |
| 16 | 100 | 48 @ 3.6 uS | 48 @ 3.6 uS |
| 13 | 80 | 30 @ 3.3 uS | 15 @ 3.3uS |
| 10 | 60 | 18 @ 3 uS | 7.5 @ 3 uS |
| 9 | 110 | 30 @ 4uS | 15 @ 4 uS |
| 6 | 100 | 60 @ 4 uS | 60 @ 4 uS |
| 4 | 50 | 20 @ 4 uS | 20 @ 4 uS |

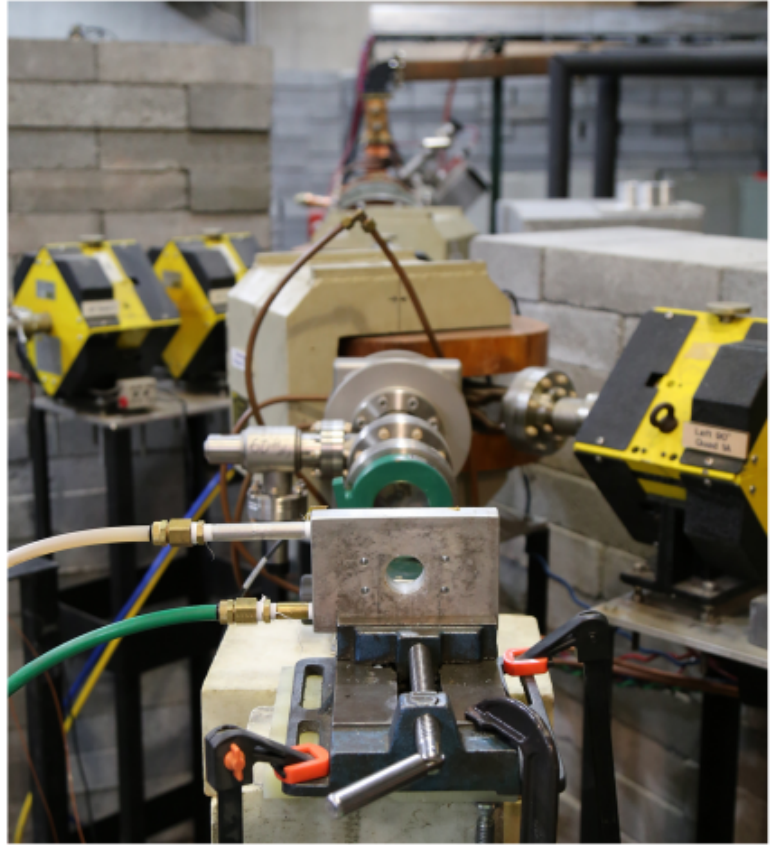
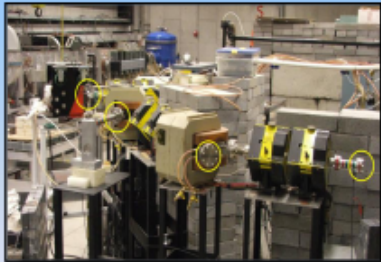

- The key issue is how well can we calibrate dose exposure?

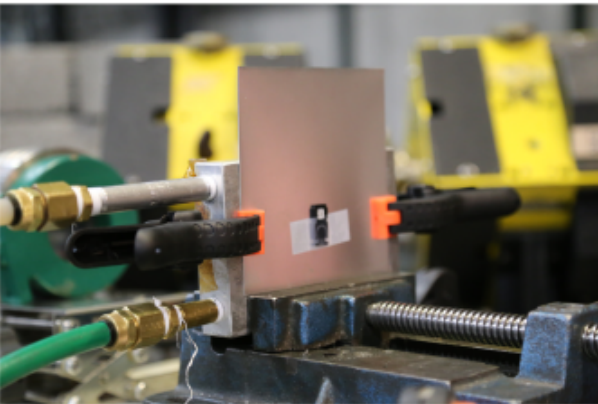

- Performed a 1 day engineering run this past spring to address this question as well as perform preliminary radiation hardness QA quartz studies

Radiation Hardness QA for quartz and other components

- Performed 1 day irradiation study on Spectrosil 2000 quartz and 3D printed ABS plastic samples
- Tests performed on May 31, 2018 at the Idaho Accelerator Center (IAC) using 8 GeV electrons
- Dose exposure rates calibrated using thermographic film dosimetry measurements
- Quartz transparency measurements taken at 10, 30, and 60 MRad exposure levels
- Plastic dogbones radiated at similar levels and tensile strength (stretching) measurements made

25 MeV LINAC (Main Hall and Airport)

RF Frequency: 2856 MHz (S-Band)

Energy Range: ~4~25 MeV (current varies)

Pulse Width: ~50ns to 4 micro seconds

Repetition Rate: single pulse to 360 Hz

Ports: 0 degree, 45 degree and 90 degree (Beam energy resolution ~ 1+/- 15%)

25B Energy vs Current

| Energy (MeV) | 0 port (mA) | 45 port (mA) | 90 port (mA) |
|--------------|-------------|------------------|------------------|
| 23 | 55 | 55 @ 3.8 μ s | 46 @ 3.6 μ s |
| 20 | 100 | 70 @ 4 μ s | 65 @ 4 μ s |
| 16 | 100 | 48 @ 3.6 μ s | 48 @ 3.6 μ s |
| 13 | 80 | 30 @ 3.3 μ s | 15 @ 3.3 μ s |
| 10 | 60 | 18 @ 3 μ s | 7.5 @ 3 μ s |
| 9 | 110 | 30 @ 4 μ s | 15 @ 4 μ s |
| 6 | 100 | 60 @ 4 μ s | 60 @ 4 μ s |
| 4 | 50 | 20 @ 4 μ s | 20 @ 4 μ s |

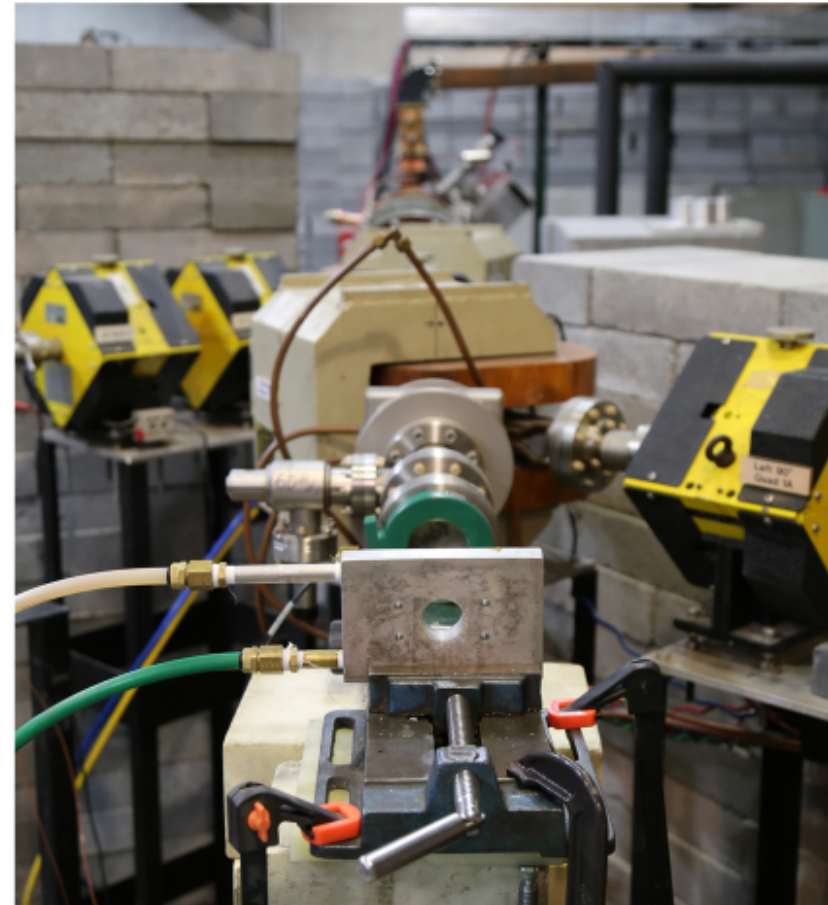
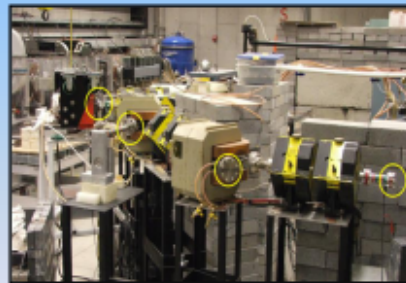

Beam Dose Exposure Rate Calibrations (May 2018)

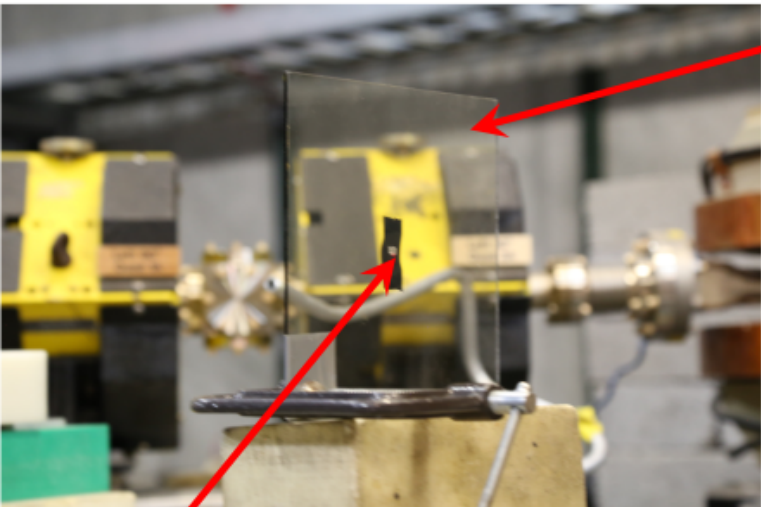

Glass slide for spot profile measurements

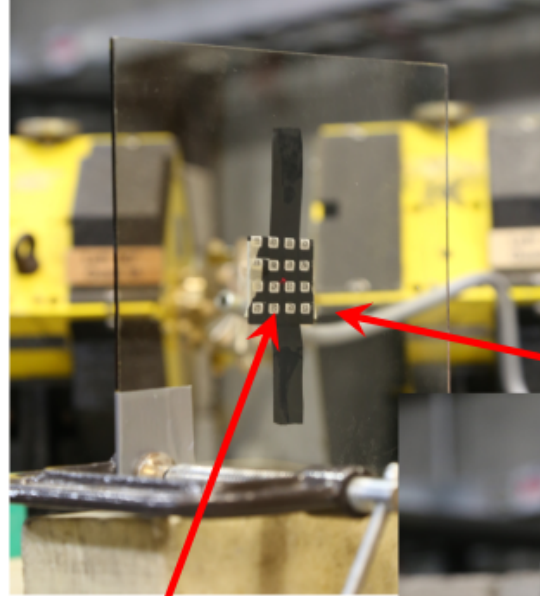

ISU MS degree student Connor Harper's thesis based on this work:
<https://www2.cose.isu.edu/~mcnudust/publication/studentWork/connorHarperThesis.pdf>

OSL arrays for dose profile measurements

Optically Stimulated Luminescence (OSL) dosimeter (~ 7 mm by 7 mm square)



Laser alignment

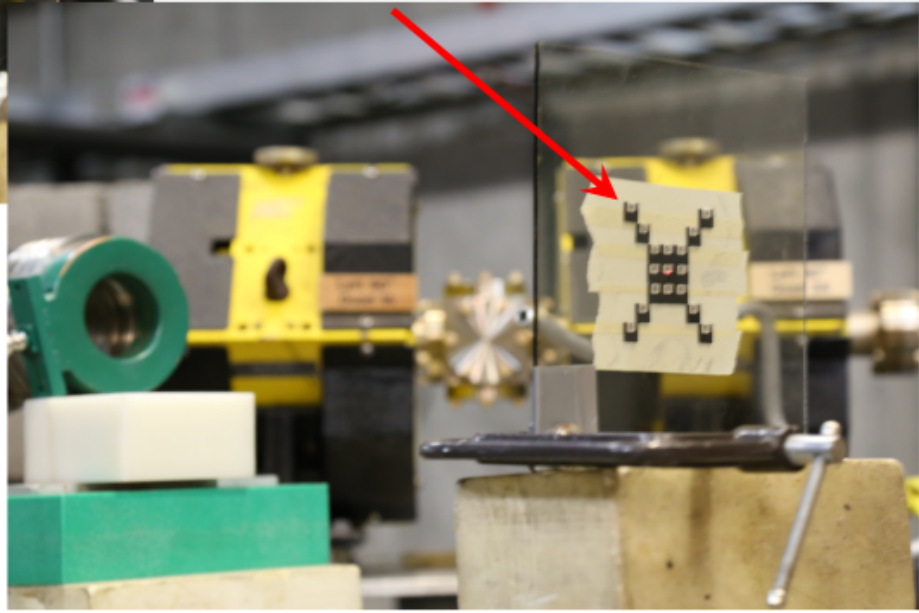

Quartz Irradiations (May 2018)

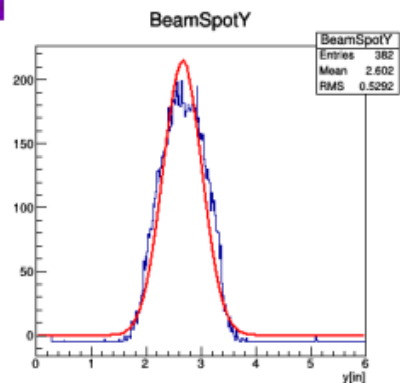
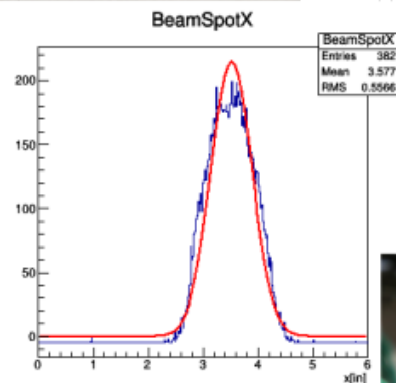
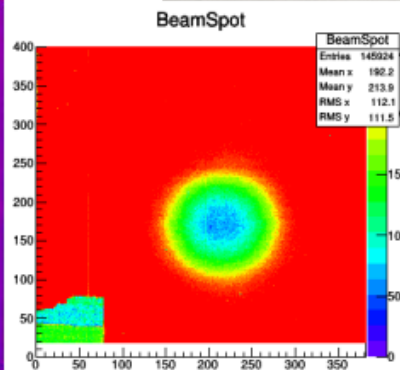
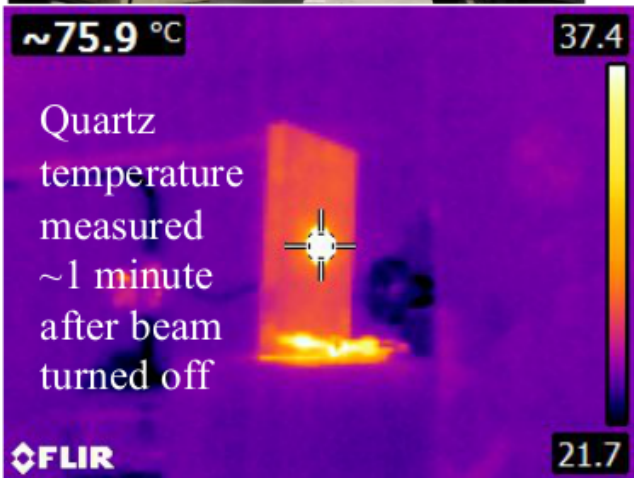
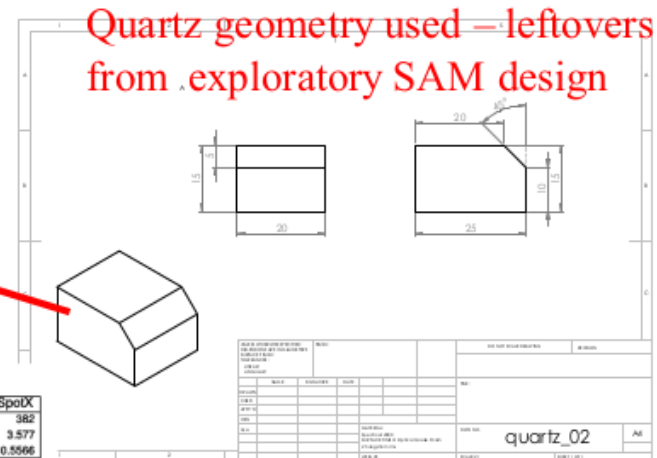
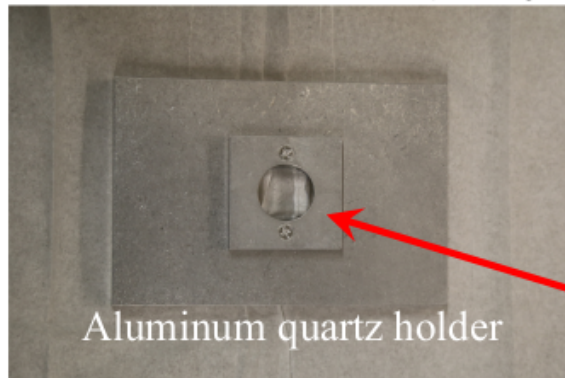

2018-05-31_15-01_Pulses_1006_50cm.png
 x-center = 3.512 in, y-center = 2.661 in
 glass plate at 50cm from beam window

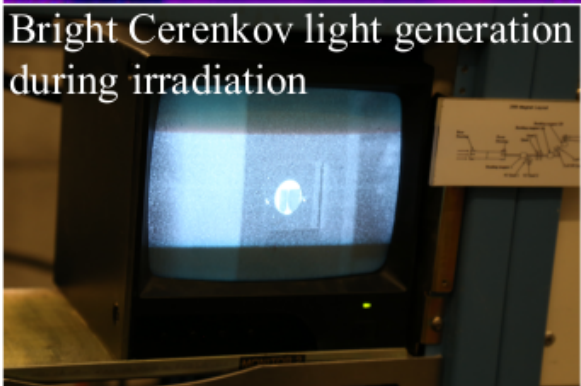

Quartz Transparency Measurements

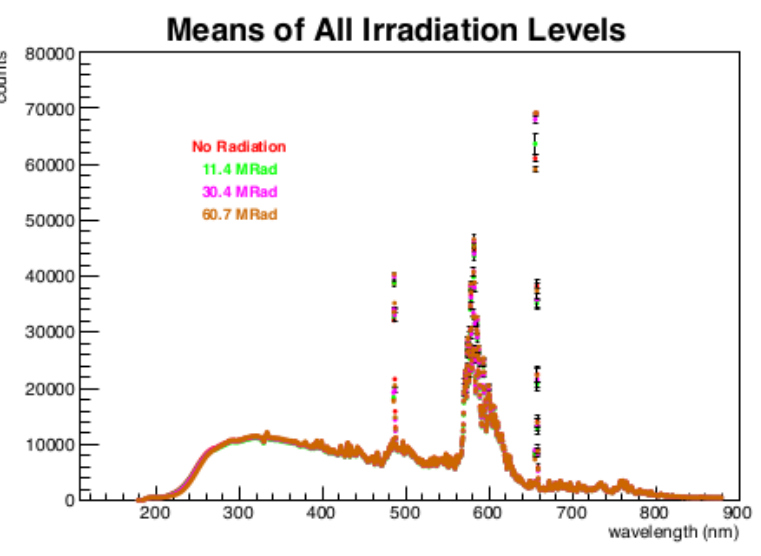
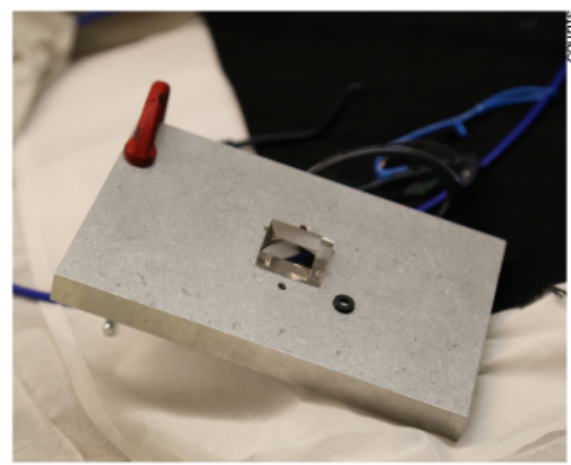
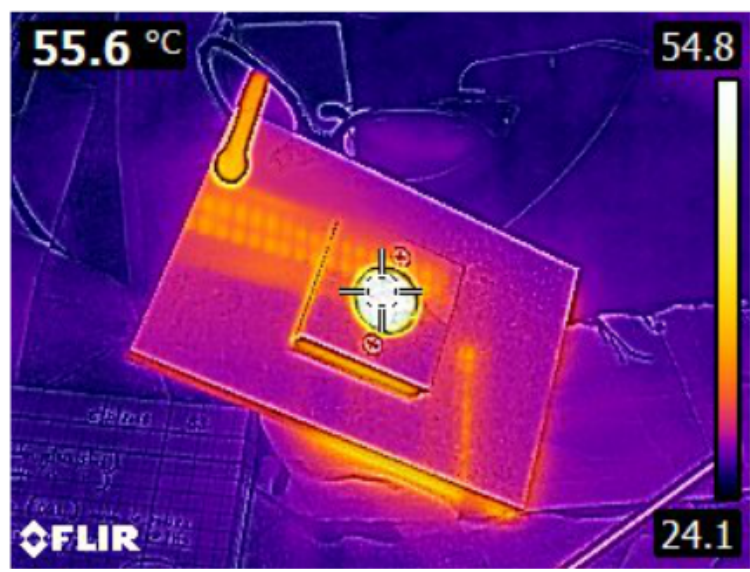
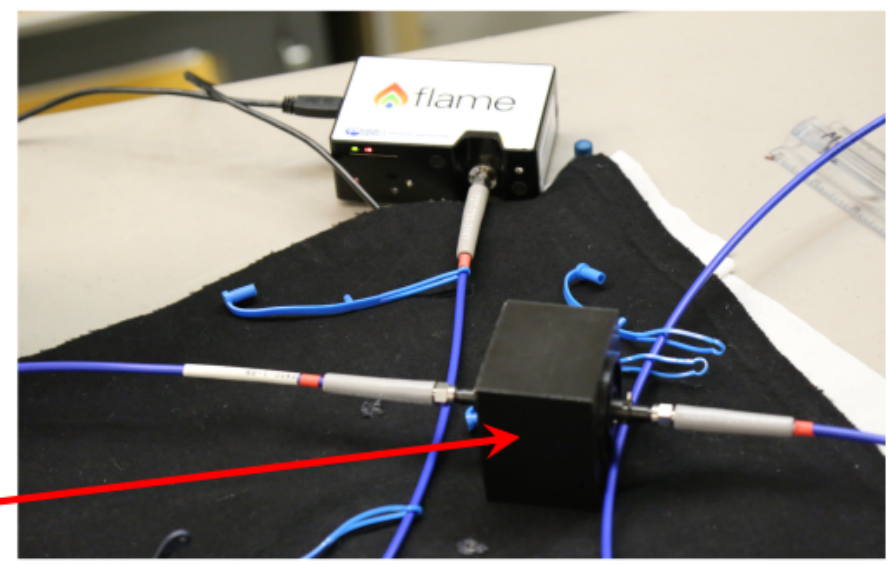
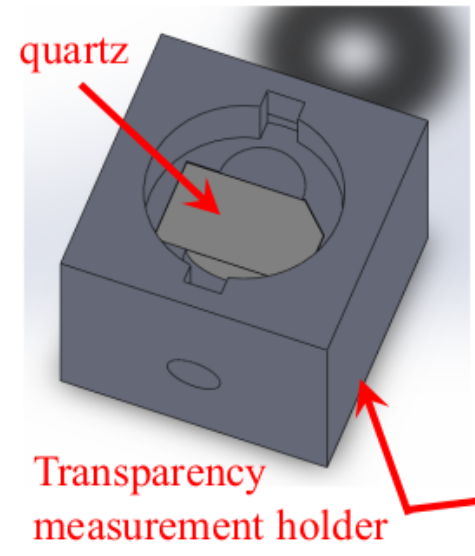
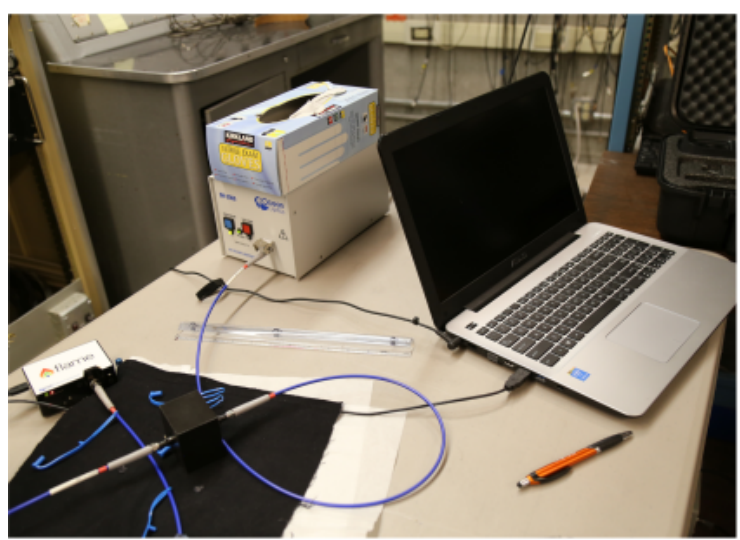

Quartz Transparency Preliminary Results

Means of All Irradiation Levels

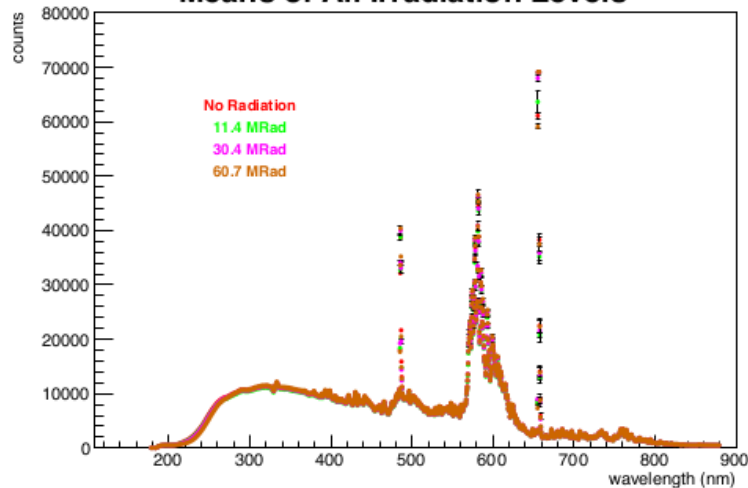

- Beam setup: 8 MeV, 50 mA I_{peak} , 500 ns pulse width at 250 Hz rep-rate
- Quartz sample mounted 0.5 m from beampipe exit window
- Dose exposure calibrations give ~ 253 Rad/pulse
- Irradiated sample for 3, 8, and then 16 minutes
- Measured light transmission (four times) after each irradiation and averaged

Unirradiated minus Irradiated

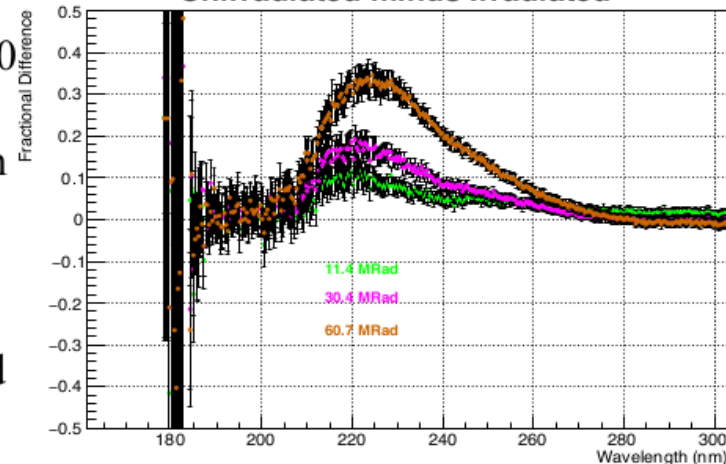

Unirradiated minus Irradiated

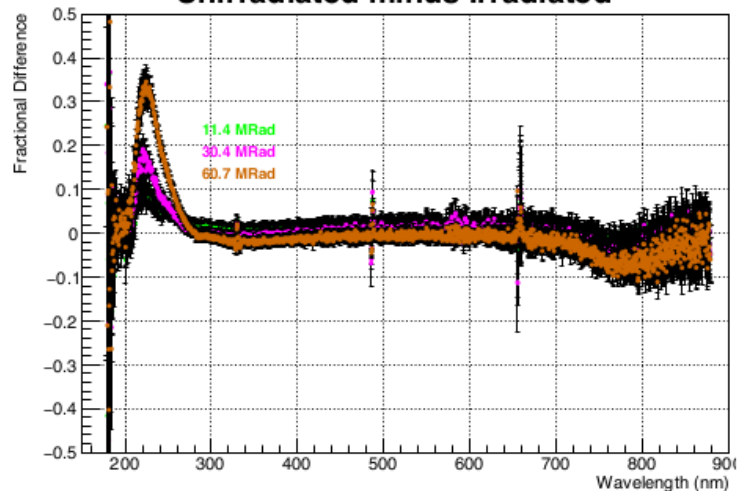

Systematic Error

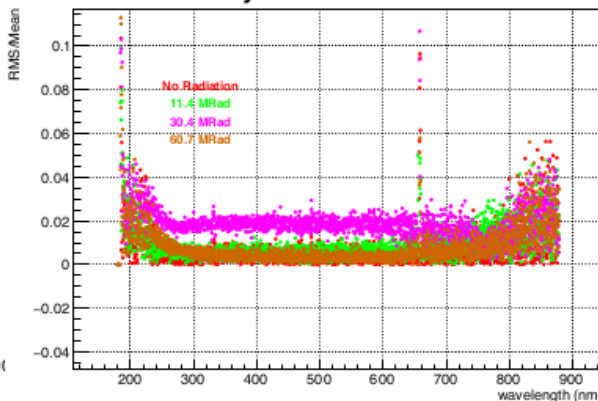

Unirradiated minus Irradiated

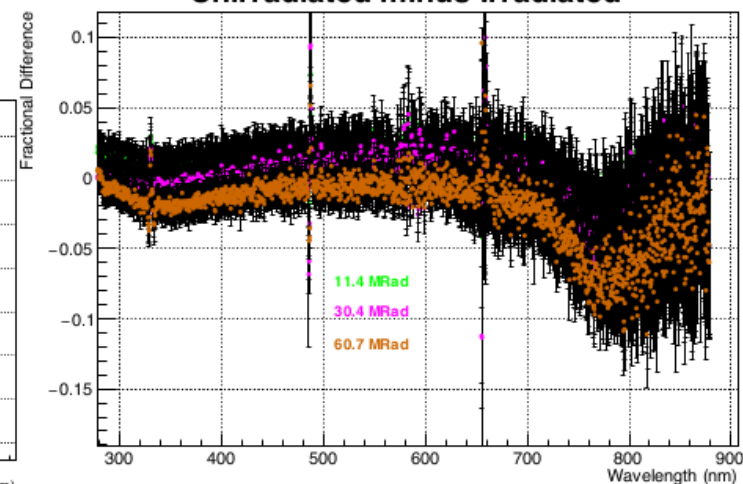

Quartz Rad Hardness Preliminary Results Summary

- Apparent onset of radiation damage seen in the UV region (between 200 – 270 nm)
- These results need to be double-checked:
 - Perform more in-depth future irradiation study
 - Examine a few different pieces (same geometry), perform more transparency measurements at smaller intervals of exposure, and redesign apparatus to give less systematic variations
- We've already seen from reflectivity measurements, combined with MAMI testbeam results, that the deep UV part of the spectrum does not seem as important or contributing as the UV/Vis part--due to cathode sensitivity and QE
- Perhaps a measurement using a SAM-type or even Moller ring-5 prototype detector during irradiations could show how this effect is dampened by the PMT; use a cathode with very low QE in the < 280 nm region

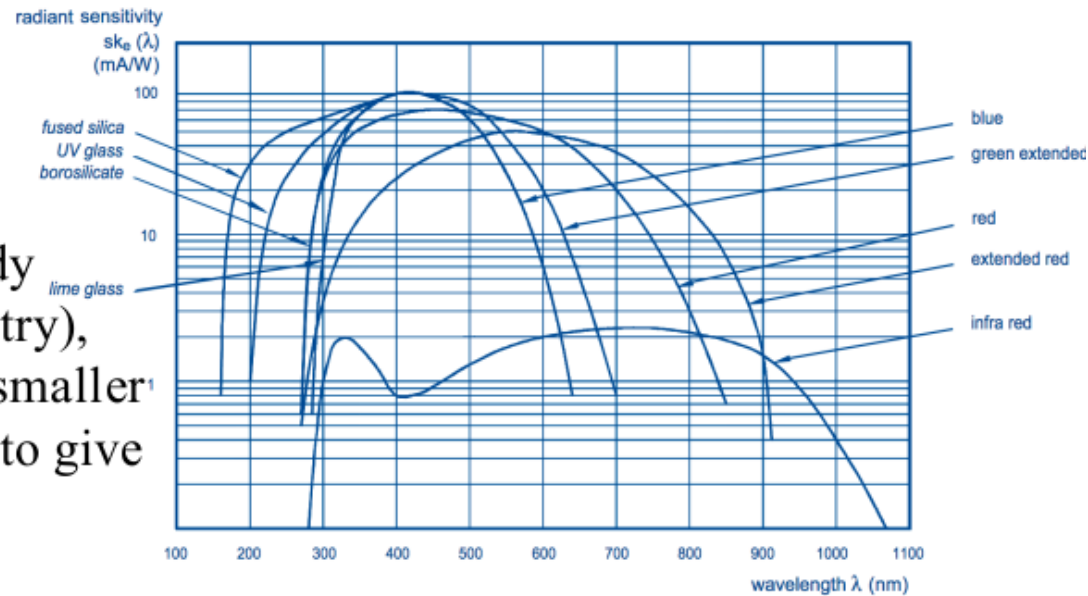

Fig.2 Typical spectral sensitivity characteristics of standard photocathodes with associated window materials.

$$QE (\%) \approx \frac{124}{\lambda(\text{nm})} \times \text{radiant sensitivity (mA/W)}$$

PMT Window Characteristics

| type of window glass | cut-off wavelength, -10% (nm) | refractive index |
|----------------------|-------------------------------|------------------|
| lime glass | 300 | 1.54 (at 400 nm) |
| borosilicate | 270 | 1.50 (at 400 nm) |
| UV glass | 190 | 1.49 (at 400 nm) |
| fused silica | 160 | 1.47 (at 400 nm) |
| | | 1.50 (at 250 nm) |
| sapphire | 150 | 1.80 (at 400 nm) |

Simulated Yields from Photons (1A Full-scale)

ShowerMax 1A Photon Response

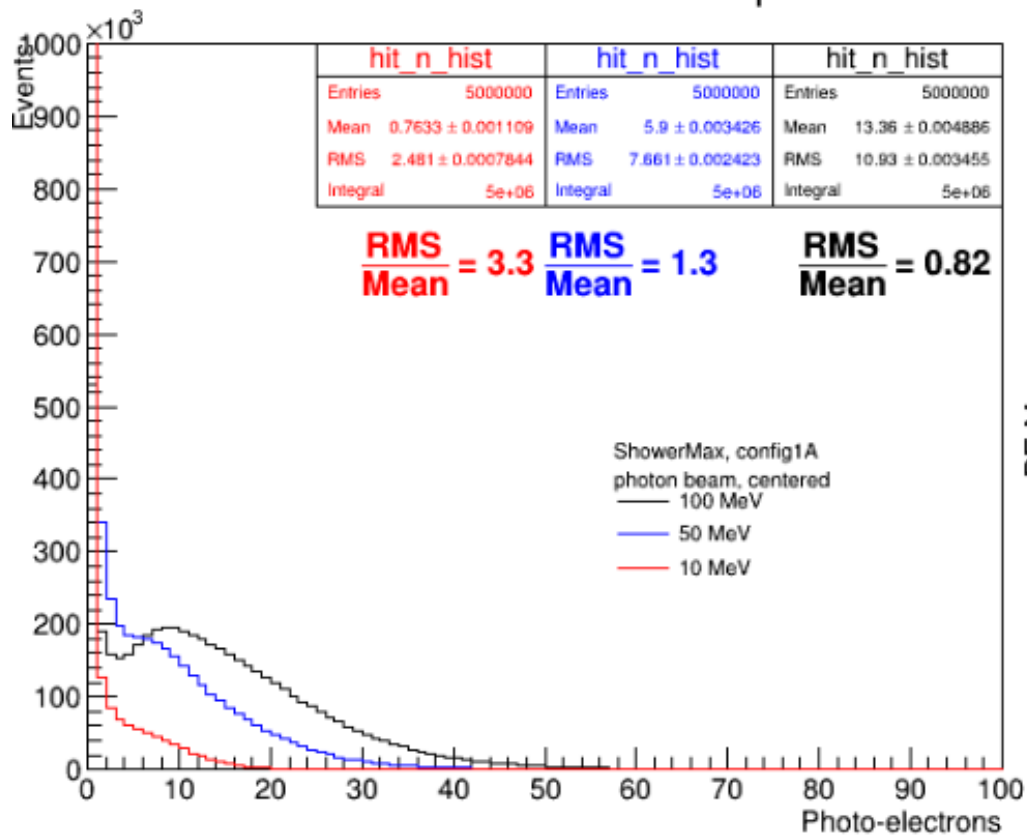

Config 1A - Photon Beam

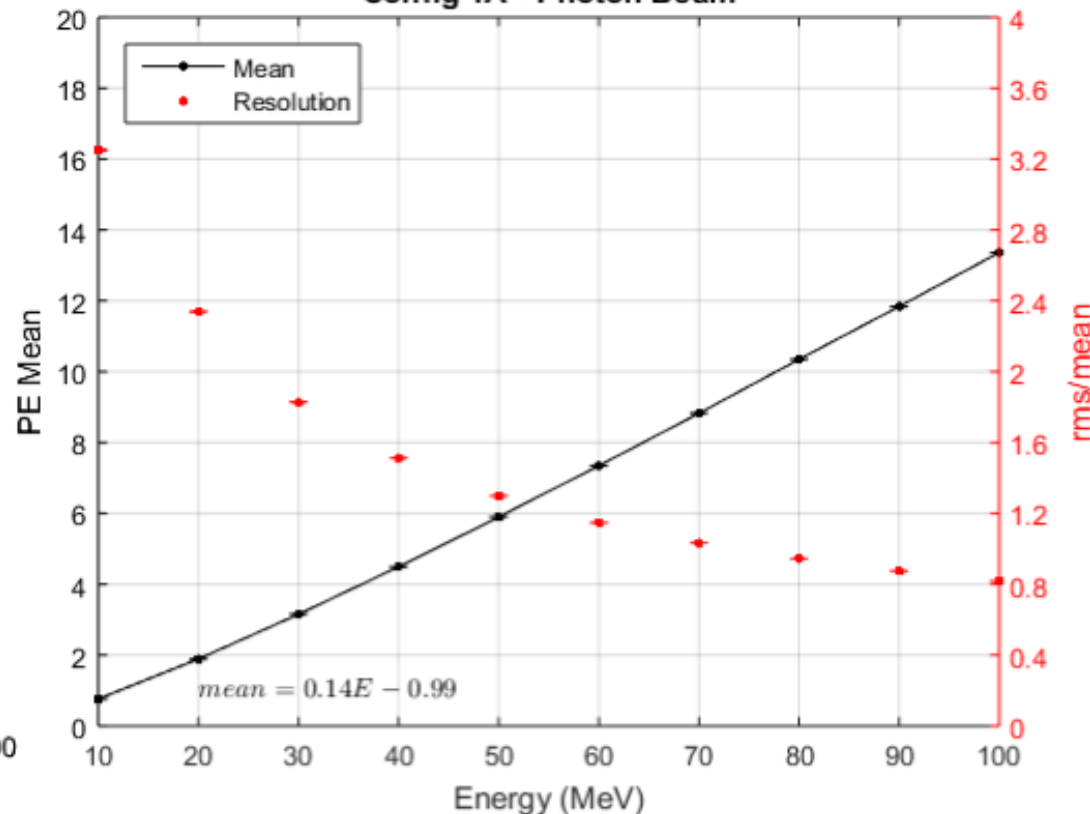

Simulated Yields from Pions (1A & 1B Full-scale)

ShowerMax Pion Response

ShowerMax Pion Response

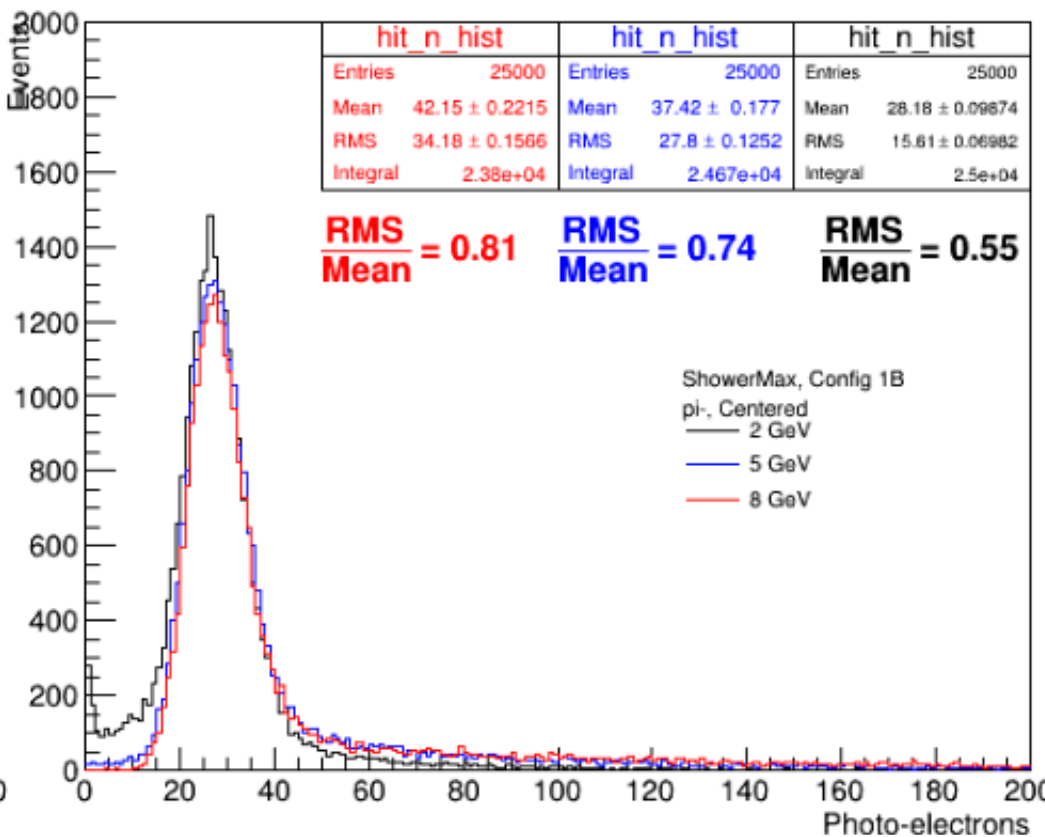
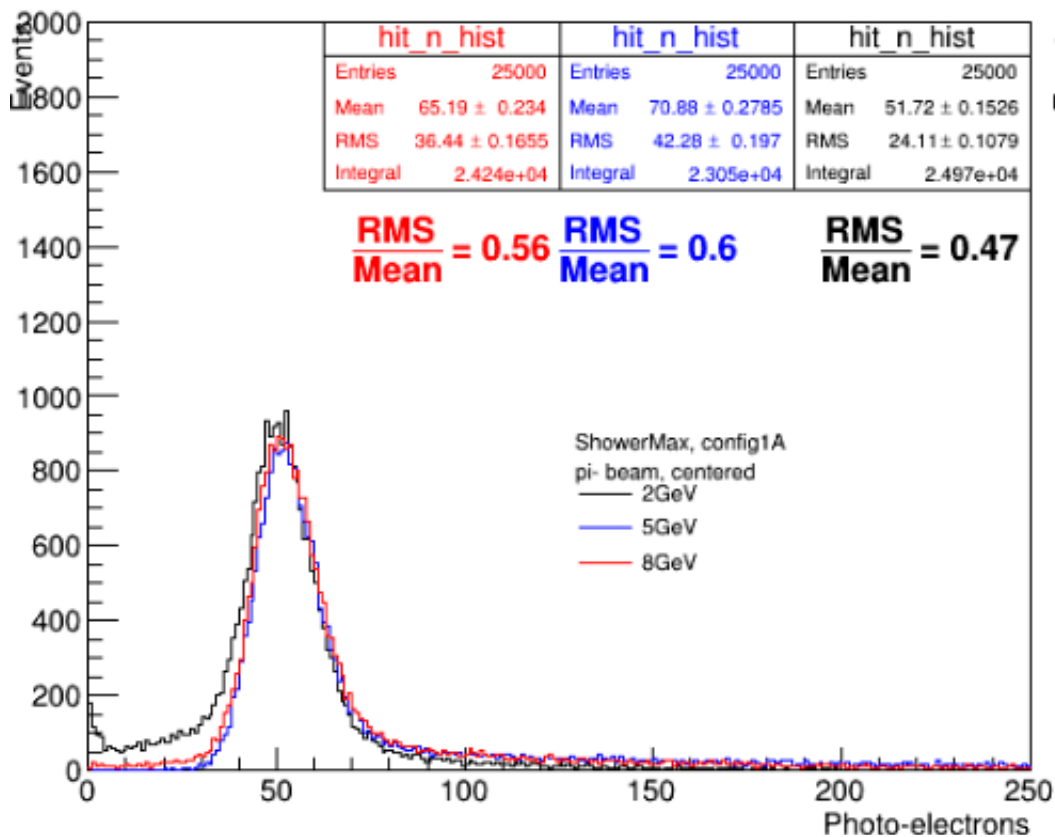

Simulated MIP signal for cosmic-ray tests (Full-scale)

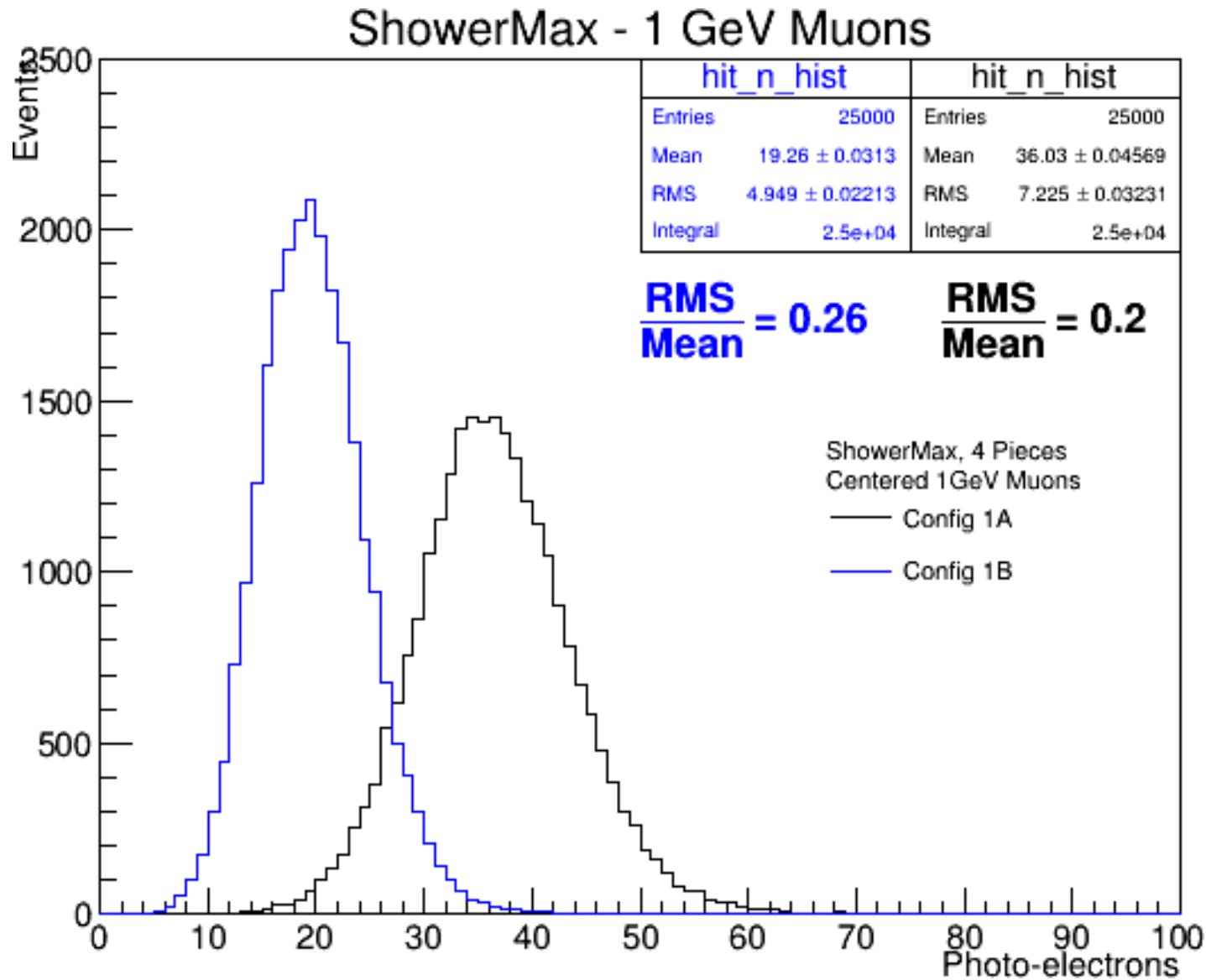

Uniformity Studies: 1A PE means along ϕ and r

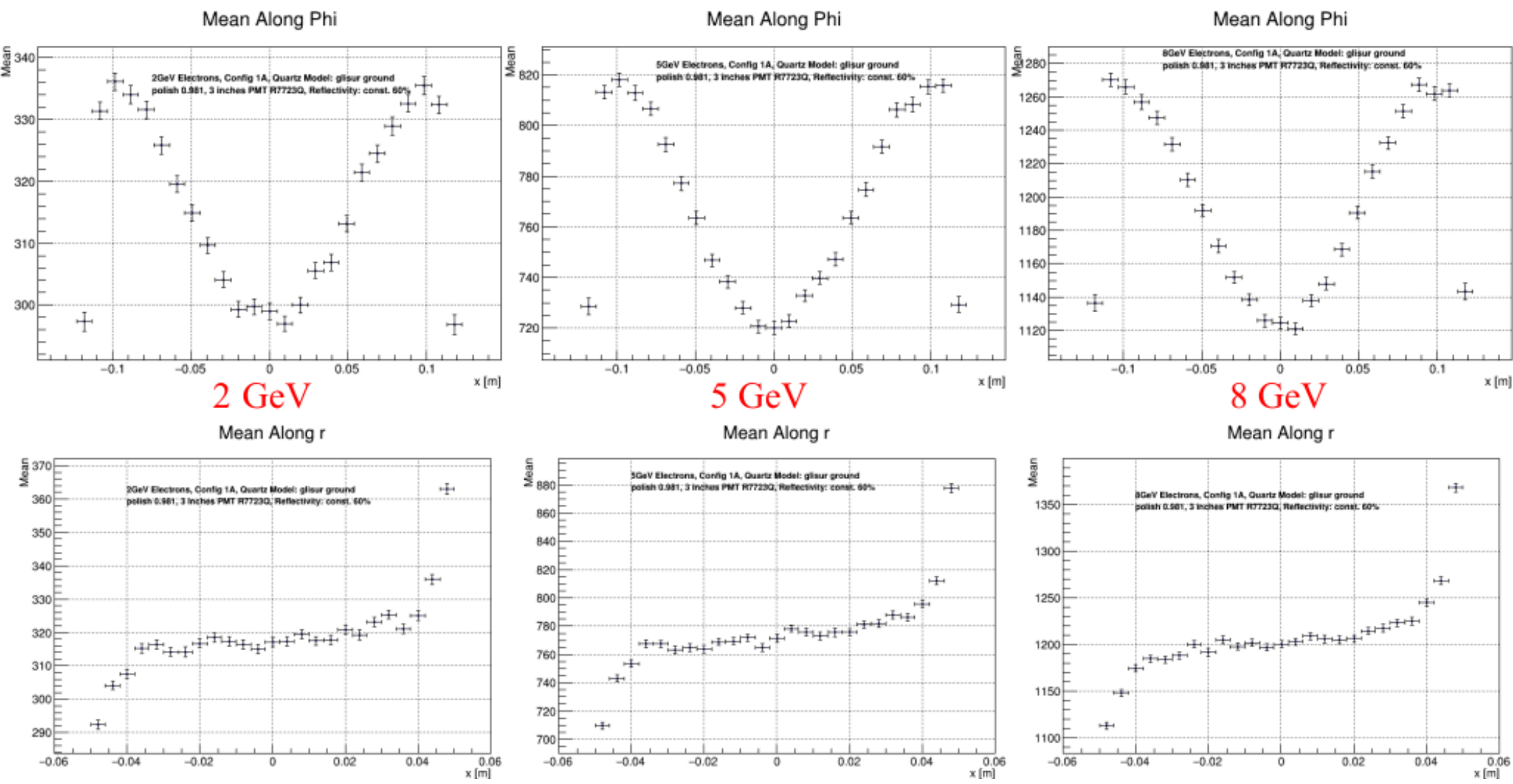

Uniformity Studies: 1A Resolutions along ϕ and r

Resolution Along Phi

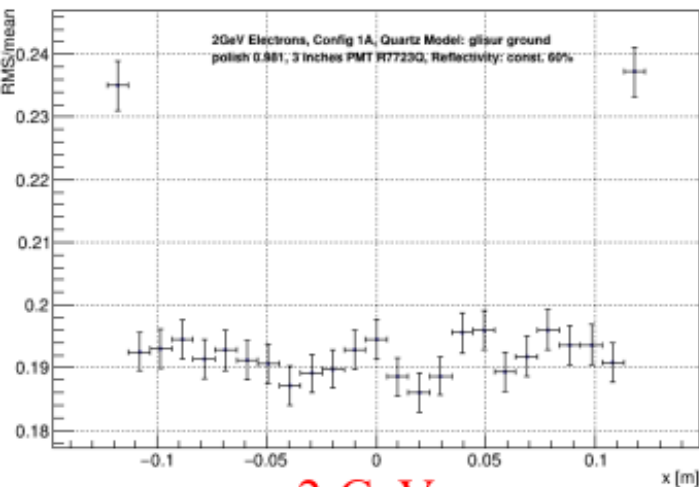

2 GeV

Resolution Along r

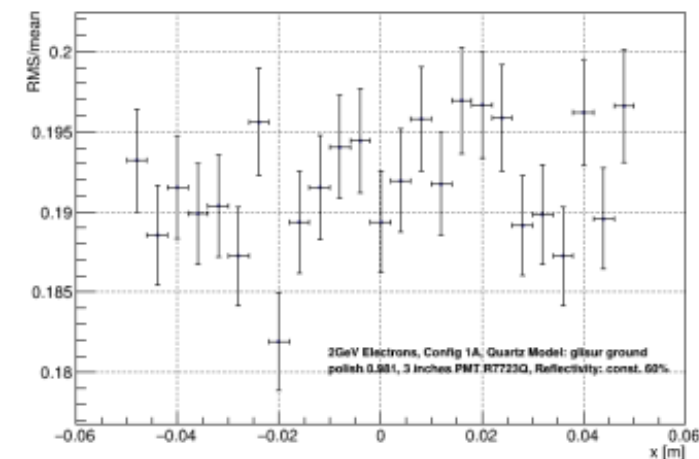

Resolution Along Phi

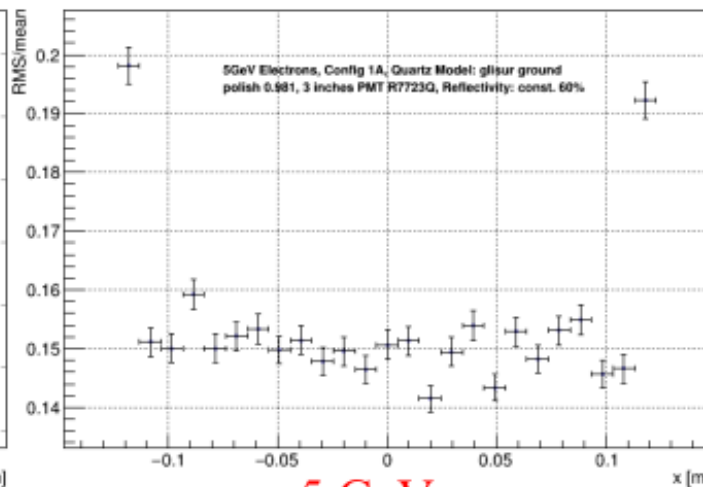

5 GeV

Resolution Along r

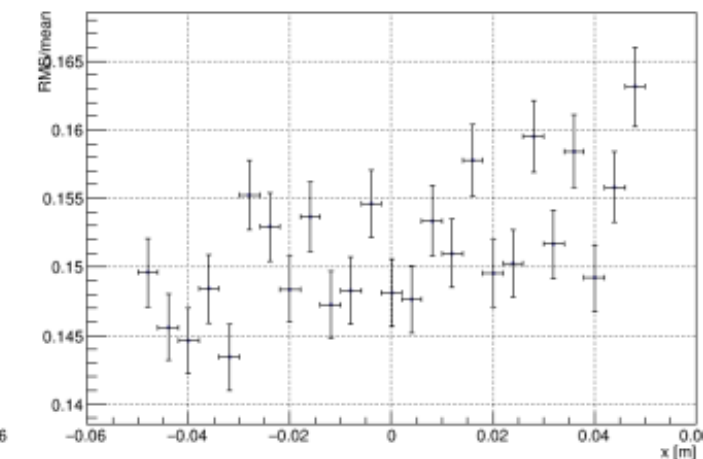

Resolution Along Phi

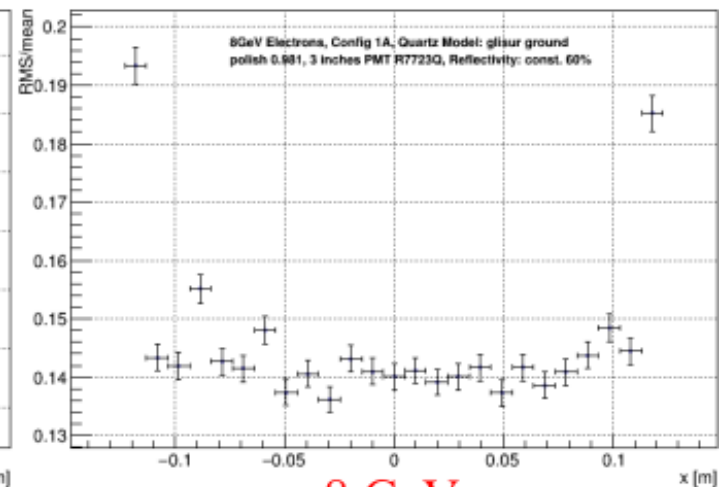

8 GeV

Resolution Along r

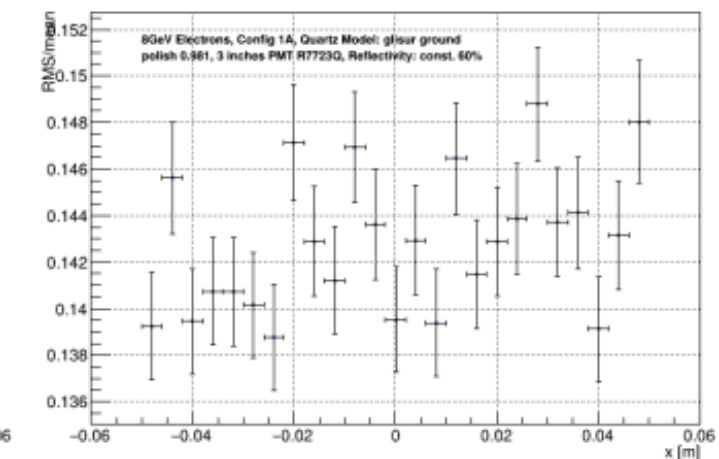

Candidate Design for Stack Prototype: Config #2

Non-uniform Benchmarking Showermax

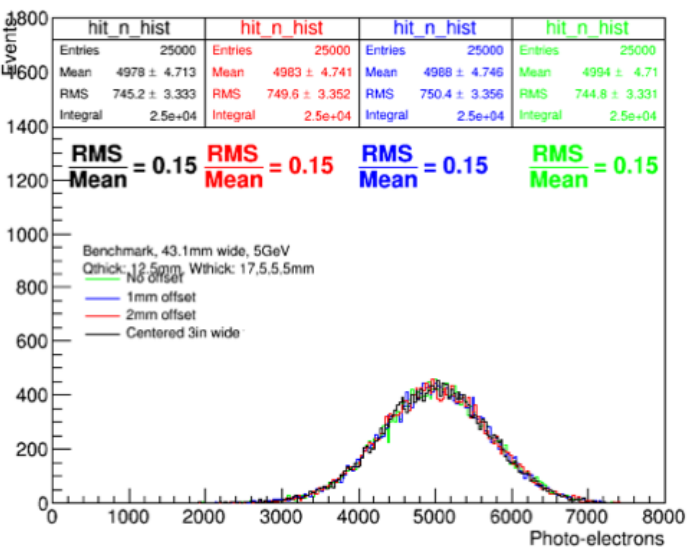

BenchMarking MC Visualization

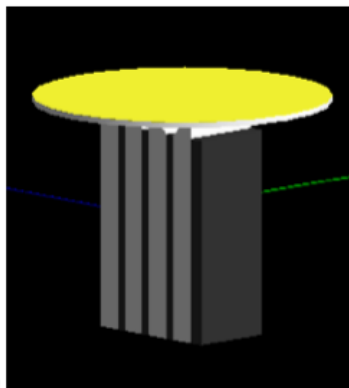

Full Scale MC Vis.

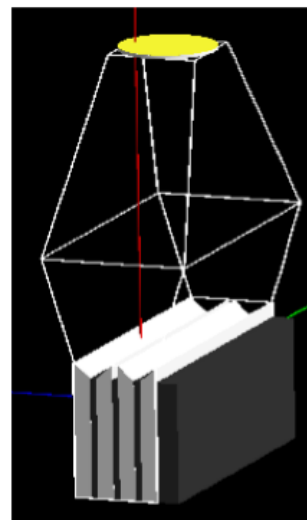

ShowerMax - Config 2

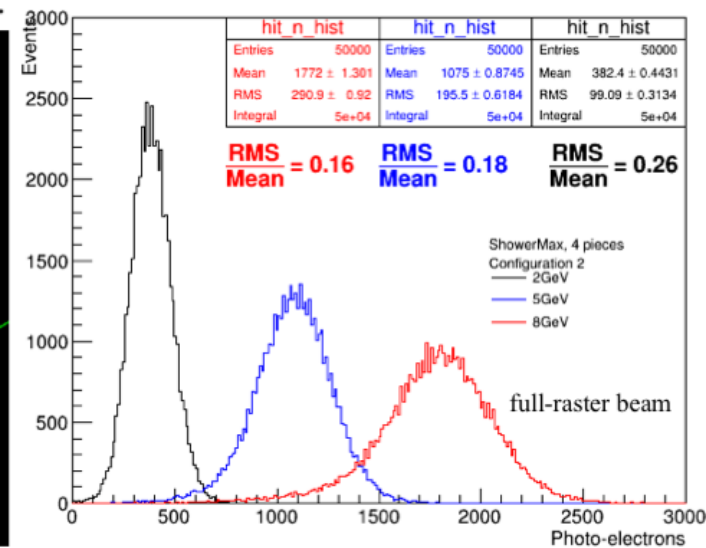

| Config # | t_f (mm) | t_q (mm) | t_w (mm) | b (mm) | a (mm) | X_0 | R_{mol} (mm) | Leakage (%) 2, 5, 8 GeV from G4 MC | 1mm offset Leakage (%) | 2mm offset Leakage (%) | Bench. Mean PEs | Bench. RMS / Mean | full- scale Mean PEs | full-scale RMS / Mean |
|----------|------------|------------|------------|--------|--------|-------|----------------|---|---------------------------------|---------------------------------|-----------------------|-------------------------|-------------------------------|-----------------------------|
| 2 | 17 | 12.5 | 5 | 65 | 43.2 | 9.5 | 11.0 | ~0 ~0 | ~0 ~0 | ~0 ~0 | 2412 4994 | 0.19 0.15 | 382 1075 1772 | 0.26 0.18 0.16 |

Candidate Design for Stack Prototype: Config #3

Configuration 3 Benchmarking Showermax

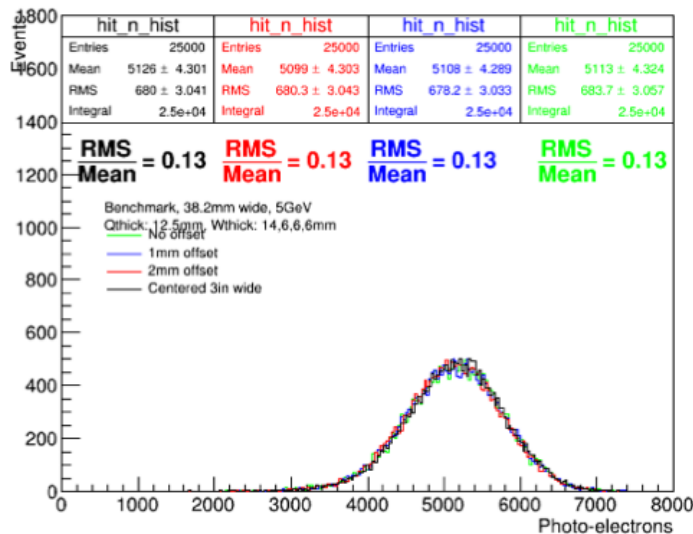

BenchMarking MC Visualization

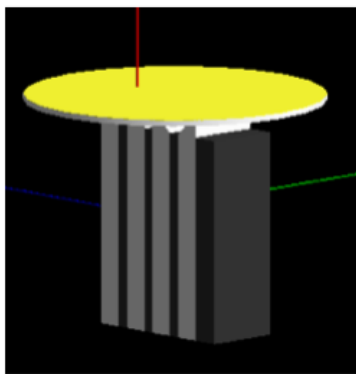

Full Scale MC Vis.

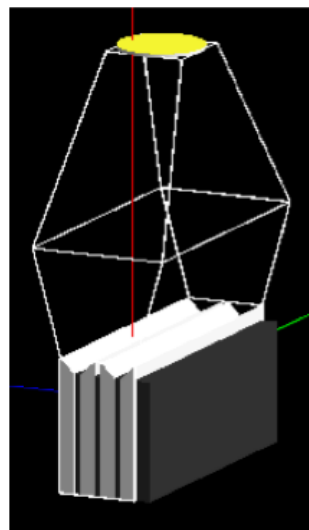

ShowerMax - Config 3

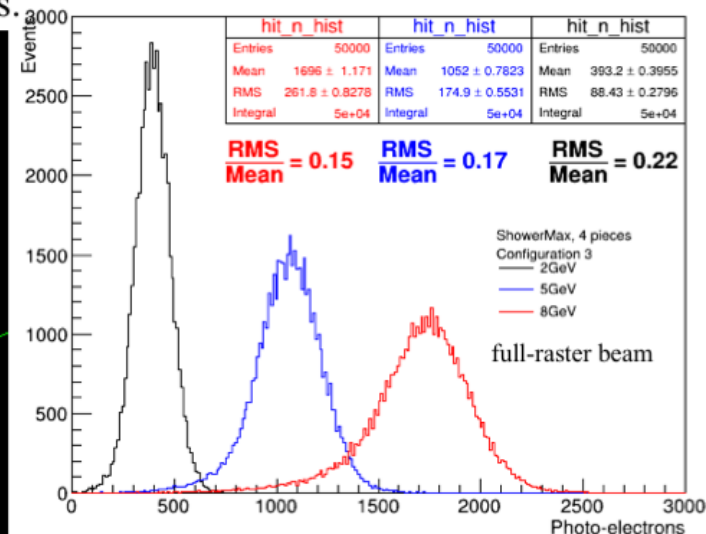

| Config # | t_f (mm) | t_q (mm) | t_w (mm) | b (mm) | a (mm) | X_0 | R_{mol} (mm) | Leakage (%) 2, 5, 8 GeV from G4 MC | 1mm offset Leakage (%) | 2mm offset Leakage (%) | Bench. Mean PEs | Bench. RMS / Mean | full- scale Mean PEs | full-scale RMS / Mean |
|----------|------------|------------|------------|--------|--------|-------|----------------|---|---------------------------------|---------------------------------|-----------------------|-------------------------|-------------------------------|-----------------------------|
| 3 | 14 | 12.5 | 6 | 68 | 38.2 | 9.5 | 11.0 | 0.5 0.3 | 0.6 0.4 | 0.8 0.5 | 2412 5113 | 0.19 0.13 | 393 1052 1696 | 0.22 0.17 0.15 |

Candidate Design for Stack Prototype: Config #4

Config4 Benchmarking Showermax - 5GeV

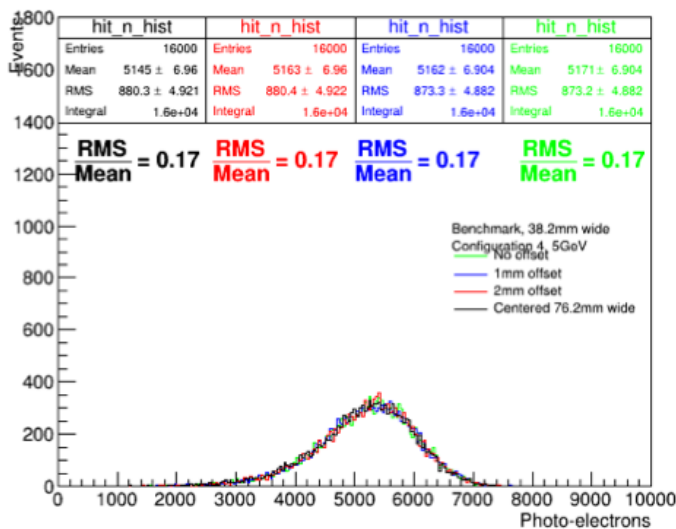

BenchMarking MC Visualization

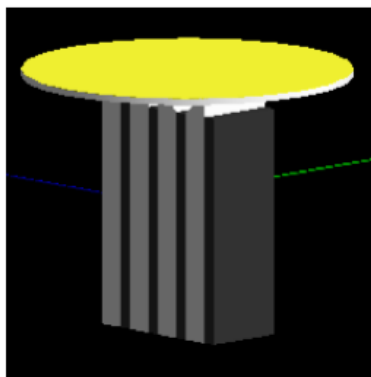

Full Scale MC Vis.

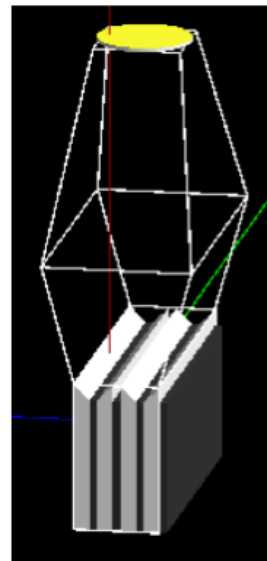

ShowerMax - Config 4

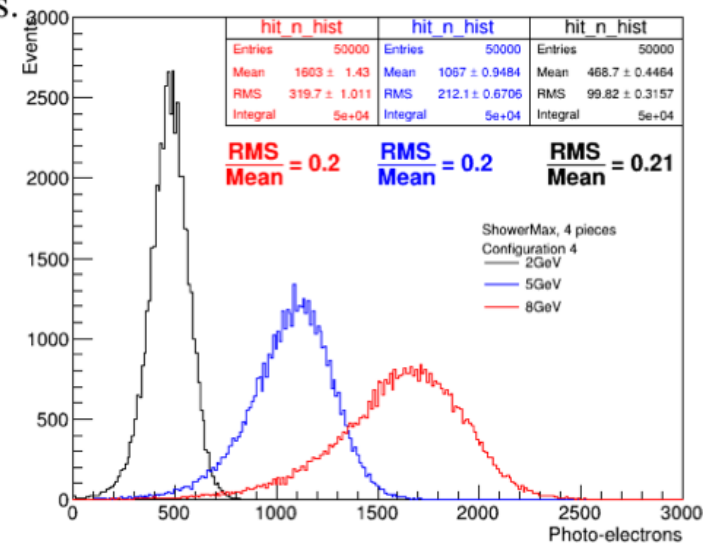

| Config # | t_f (mm) | t_a (mm) | t_w (mm) | b (mm) | a (mm) | X_0 | R_{mol} (mm) | Leakage (%) 2, 5, 8 GeV from G4 MC | 1mm offset Leakage (%) | 2mm offset Leakage (%) | Bench. Mean PEs | Bench. RMS / Mean | full- scale Mean PEs | full-scale RMS / Mean |
|----------|------------|------------|------------|--------|--------|-------|----------------|---|---------------------------------|---------------------------------|-----------------------|-------------------------|-------------------------------|-----------------------------|
| 4 | 6 | 12.5 | 6 | 68 | 38.2 | 7.3 | 11.0 | ~0 ~0 | ~0 ~0 | ~0 ~0 | 5171 | 0.17 | 469 1067 1603 | 0.21 0.20 0.20 |

Simulation Results for new Stack Configs

| Config # | t_f (mm) | t_q (mm) | t_w (mm) | b (mm) | Max A (mm) | X | Tungsten Weight (N) | Quartz Weight (N) | Total Weight (N) | Moliere R_m (mm) |
|----------|----------|----------|----------|--------|------------|------|---------------------|-------------------|------------------|------------------|
| 1A | 8 | 10 | 8 | 64 | 44.59 | 9.46 | 156.09 | 35.57 | 191.66 | 11.00 |
| 1B | 8 | 6 | 8 | 48 | 61.48 | 9.33 | 156.09 | 35.57 | 191.66 | 11.00 |
| 4A | 6 | 10 | 8 | 64 | 44.59 | 8.89 | 146.33 | 35.57 | 181.91 | 11.11 |
| 4B | 6 | 6 | 6 | 42 | 65.73 | 7.04 | 117.07 | 35.57 | 152.64 | 11.53 |

| Benchmark - 2GeV | | | | |
|------------------|----------|-------------|------------------------|----------------------|
| Config # | RMS/Mean | Leakage (%) | Leakage 2mm offset (%) | Leakage 2° angle (%) |
| 1A | 0.17 | 0 | 0 | -0.1 |
| 1B | 0.19 | 0 | 0 | 0.2 |
| 4A | 0.19 | 0 | 0 | - |
| 4B | 0.21 | 0 | 0 | - |

| Full Scale ShowerMax – 2GeV | | | |
|-----------------------------|-------|-------|----------|
| Config # | RMS | Mean | RMS/Mean |
| 1A | 63.36 | 315.9 | 0.20 |
| 1B | 45.46 | 197.7 | 0.23 |
| 4A** | 60.16 | 300.2 | 0.20 |
| 4B** | 39.67 | 179.3 | 0.22 |

| Benchmark - 5GeV | | | | |
|------------------|----------|-------------|------------------------|----------------------|
| Config # | RMS/Mean | Leakage (%) | Leakage 2mm offset (%) | Leakage 2° angle (%) |
| 1A | 0.13 | 0.04 | 0.09 | -0.4 |
| 1B | 0.14 | 0 | 0 | 0.2 |
| 4A | 0.17 | 0.06 | 0.3 | - |
| 4B | 0.19 | 0 | 0 | - |

| Full Scale ShowerMax – 5GeV | | | |
|-----------------------------|-------|-------|----------|
| Config # | RMS | Mean | RMS/Mean |
| 1A | 123.7 | 768.5 | 0.16 |
| 1B | 87.82 | 473.6 | 0.19 |
| 4A** | 126.8 | 677.4 | 0.19 |
| 4B** | 80.61 | 397.4 | 0.20 |

| Benchmark – 8GeV | | | | |
|------------------|----------|-------------|------------------------|----------------------|
| Config # | RMS/Mean | Leakage (%) | Leakage 2mm offset (%) | Leakage 2° angle (%) |
| 1A | 0.12 | 0 | 0 | - |
| 1B | 0.13 | 0 | 0 | - |
| 4A* | 0.18 | 0 | 0 | - |
| 4B | 0.19 | 0 | 0 | - |

| Full Scale ShowerMax – 8GeV | | | |
|-----------------------------|-------|-------|----------|
| Config # | RMS | Mean | RMS/Mean |
| 1A | 183.2 | 1197 | 0.15 |
| 1B | 129.1 | 732.3 | 0.18 |
| 4A** | 187.9 | 1012 | 0.19 |
| 4B** | 118.8 | 591.3 | 0.20 |

Unity Gain operation with Baseline design?

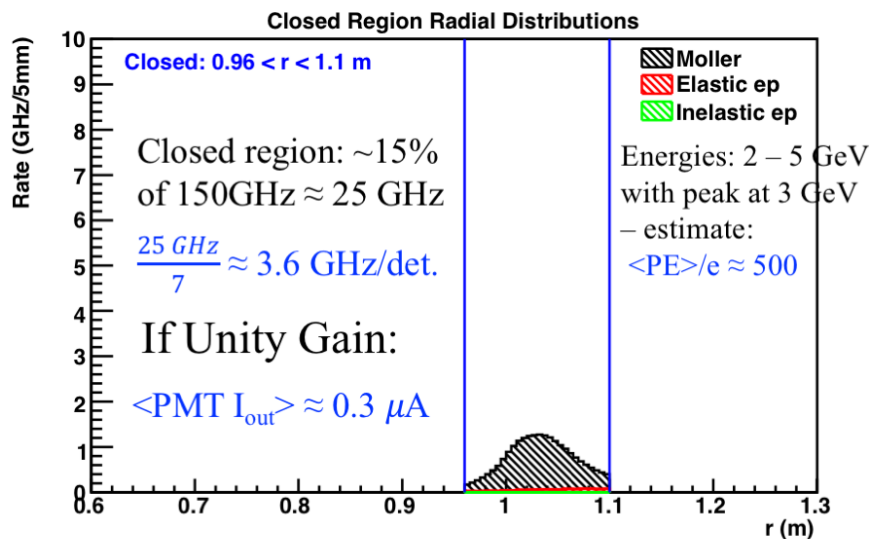
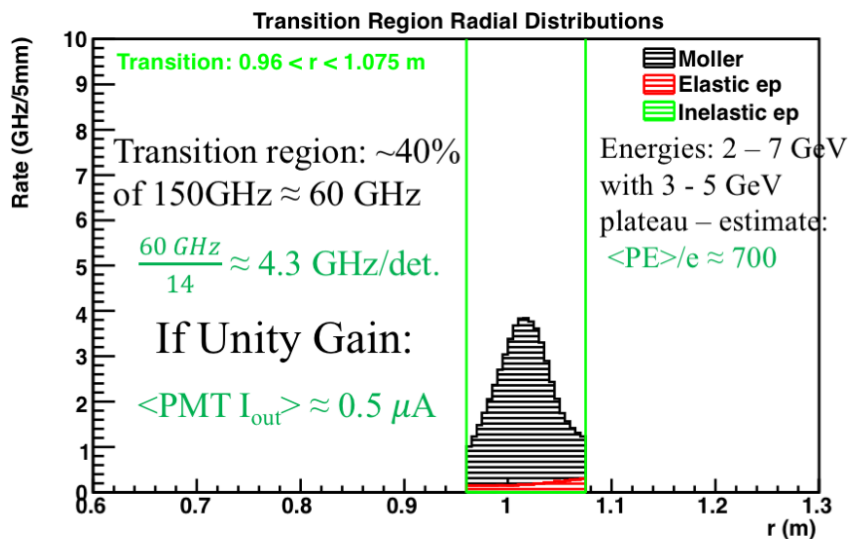
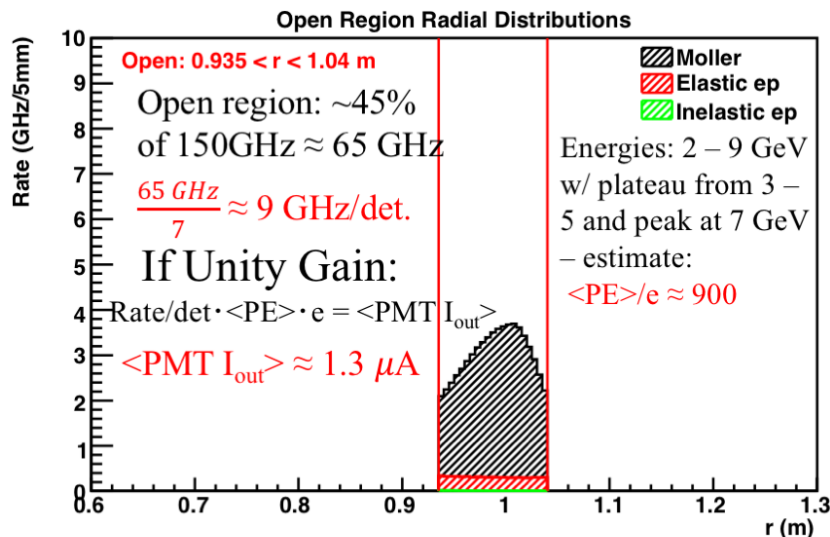
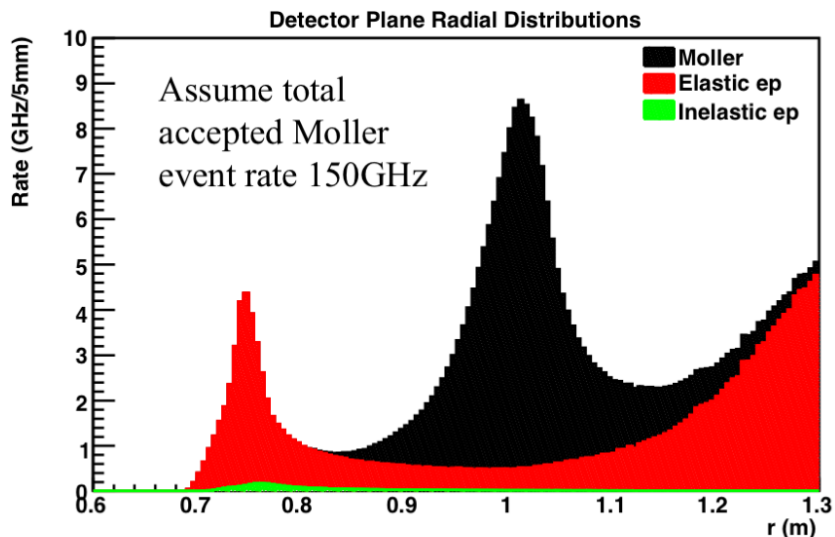

- Could be possible to use conventional 3” pmts with electronic switching between unity gain base (integrating mode) and high gain base (counting mode)

ShowerMax Prototype Construction Timeline

- Feb - Mar 2018: Benchmarking prototype frames fabricated with 3D-printer using ABS plastic (configs 1A and 1B)
- April 2018: Full-scale aluminum frame and light guide cut-outs fabricated at machine shop
- May 2018: Light guide bending and frame assembly at ISU for full-scale configs 1A and 1B
- June 2018: Config 1A full-scale and benchmarking prototype frames and LG delivered to SBU for stack assembly and installation

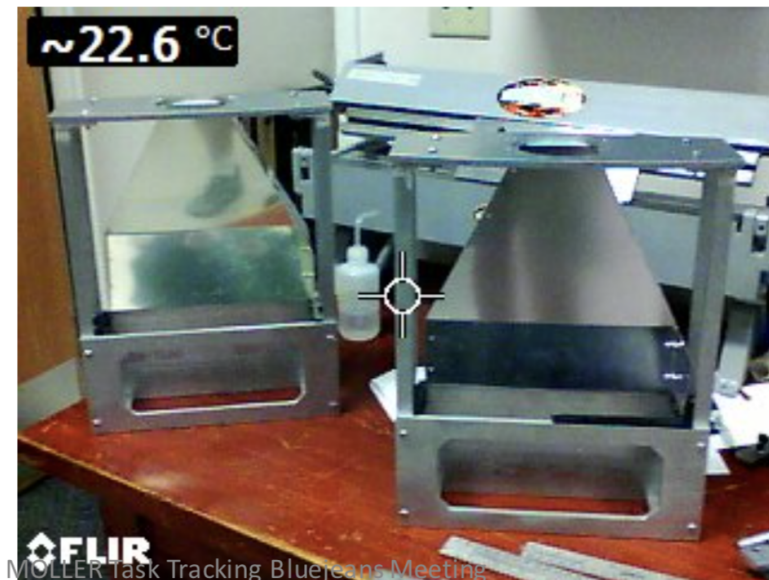
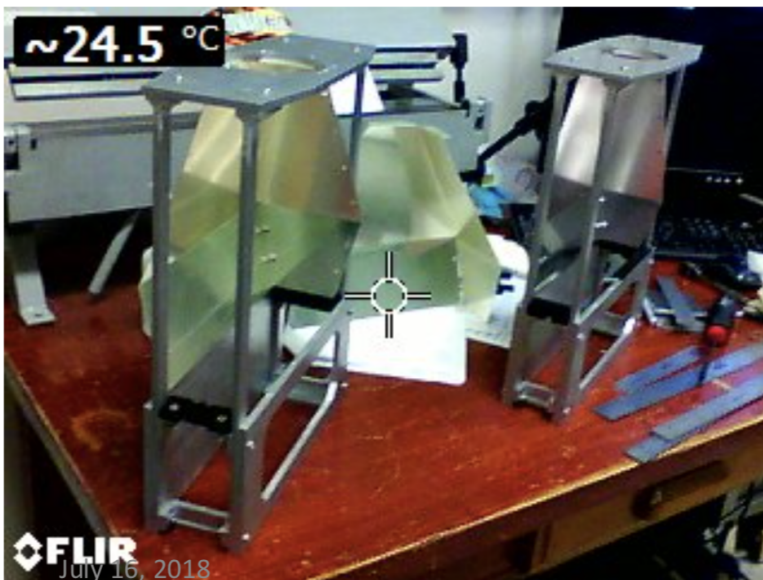

Testbeam Apparatus under construction

- Testbeam stand under construction
- Motion control system in place
- GEM system is operational, analysis software under development

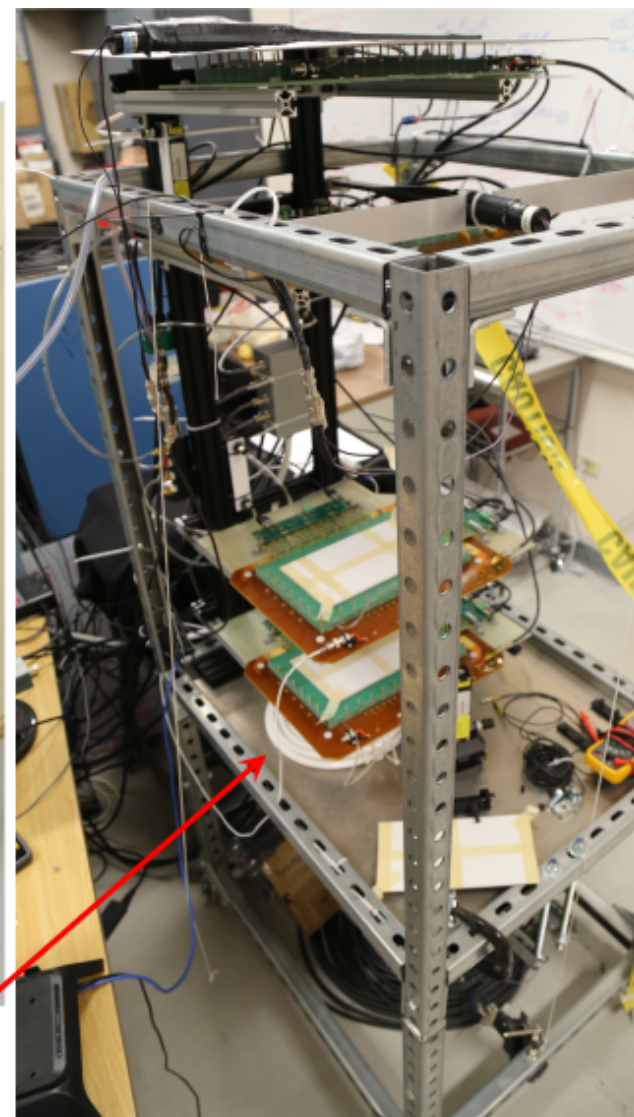
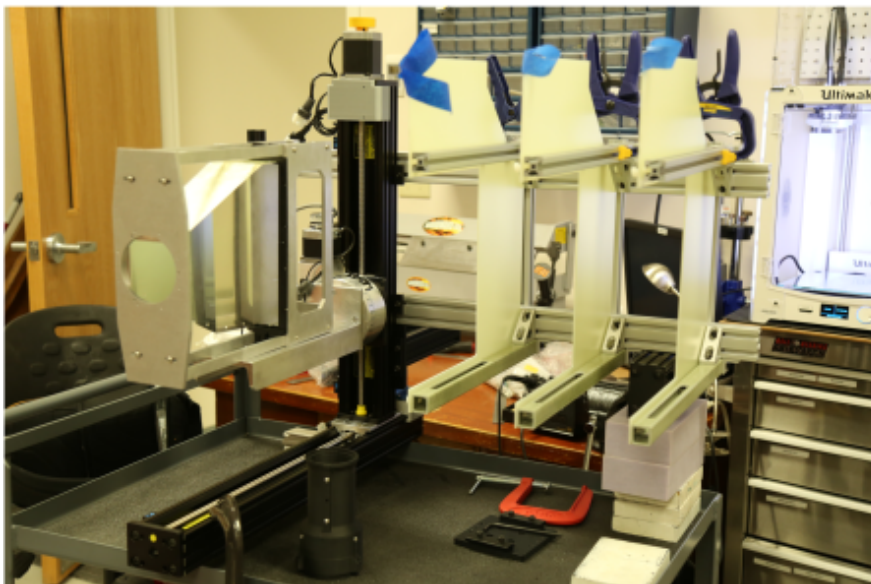

ISU Cosmic stand with 4 GEM chambers